

ZIANA INDUSTRIES

**Certified : ISO 13485:2016
CE MDR 2017/ 745**

Manufacturers & Exporters of
Dental Instruments



www.zianaindustries.com



TABLE OF CONTENTS

01	Tooth Extracting Forceps		01-49
02	Root Elevators		50-70
03	Scalpel Handles, Handles, Mouth Mirrors Scalers, Explorer / Probes		71-85
04	Endodontic Condensers, Obturation Instruments Excavators, Explorers/ Probes, CurettesSets		86-96
05	Amalgam Pluggers / Condensers, Burnishers		87-100
06	Wax Carvers, Carvers, Chisels		101-103
07	Compsite Placement, Plastic Filling instruments		104-107
08	Curettes, Gracey Curettes, Dental Products, Knives		108-117

**TABLE OF CONTENTS**

09	Wax Porcelain & Cement Instruments Was & Modeling Instruments		118-121
10	Spatulas, Cement Spatulas		122-124
11	Files, Hoes, Knives, Wax & Plaster Knives Crane Kaplan		125-128
12	Bone Curetters, Bone Files, Bone Chisels		129-133
13	Crown Removers, Crown Instruments		134-136
14	Implants & Measuring Instruments, Suction Tubes, Bone Gauges		137-144
15	Amalgam Gums & Carriers, Retainers, Bands, Strip, Holders Napkin Holders		145-146
16	Rubber Dam Instruments, Rubber Dam Clamps		147-148

**TABLE OF CONTENTS**

17	Syringes, Tweezers, Sterilizing & Lab instruments		149-156
18	Endodontic Forceps, Tissue Forceps, Haemostatic Forceps, Towel Clamps		157-159
19	Retractors, Lip & Cheek Retractors, Hooks, Depressors & Mouth Gags, Sterilizing Forceps		160-164
20	Orthodontic, Pliers & Cutters, Rongeurs		165-179
21	Needle Holders, Scissors, Micro Surgery Set		180-186
22	Impression Trays		187-193
23	Articulators, Hollow Wares		194-200
24	Scissors, Dissecting Forceps, Needle Holders, Wire Cutting Pliers With Tungsten Carbide Inserts		201-213

Section - 01



- * Extracting Forceps
- * Root Elevators

Extracting Forceps “English Pattern”



1001
Fig 4
lower incisor



1001
Fig 4
lower incisor

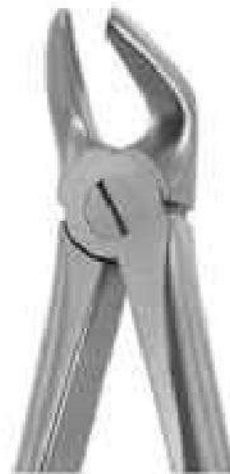

1002
Fig 8
lower premolar



1002
Fig 8
lower
premolars

Extracting Forceps “English Pattern”

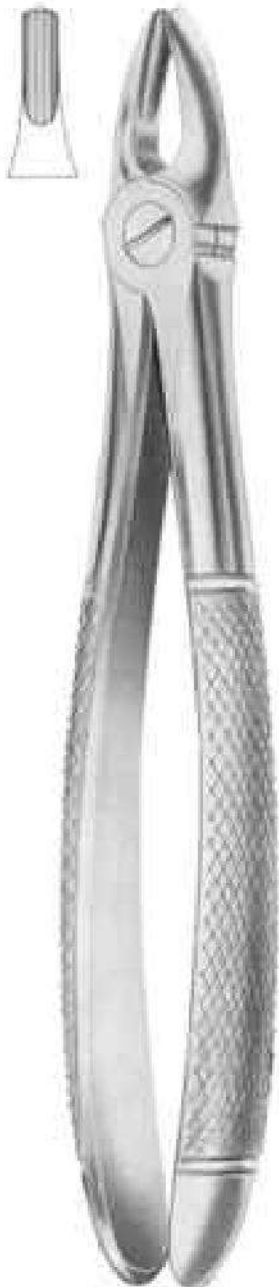

1003
Fig 1
upper centrals & canines



1004
Fig 2
upper laterals & canines



1005
Fig 3
upper incisors & canines



1006
Fig 4
upper incisors & canines



1007
Fig 7
upper
premolars



1008
Fig 8
lower
premolars



1009
Fig 13
lower
premolars

Extracting Forceps "English Pattern"



1010
Fig 13S
lower premolars
for children

1011
Fig 17
upper molars right

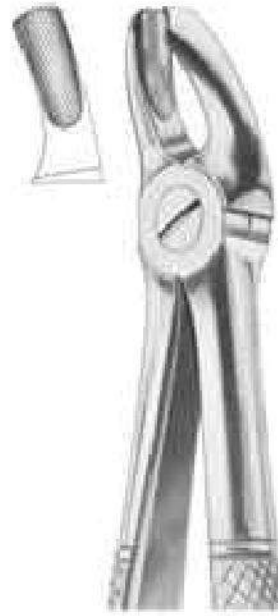

1012
Fig 18
upper molars left



1013
Fig 18A
upper molars

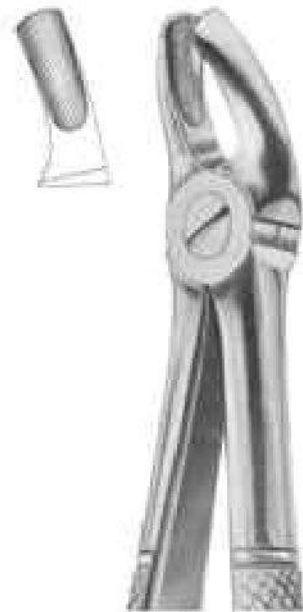

1014
Fig 18B
upper molars



1015
Fig 19
upper third molars

Extracting Forceps “English Pattern”



1016
Fig 20
upper third molars



1017
Fig 21
lower molars



1018
Fig 22
lower molars



1019
Fig 22S
lower molars
for children



1020
Fig 22G
lower molars



1021
Fig 23
lower molars right



1022
Fig 24
lower molars left

Extracting Forceps "English Pattern"



1023
Fig 29
upper roots



1024
Fig 29S
upper roots for children



1025
Fig 30
upper roots



1028
Fig 30S
upper roots
for children

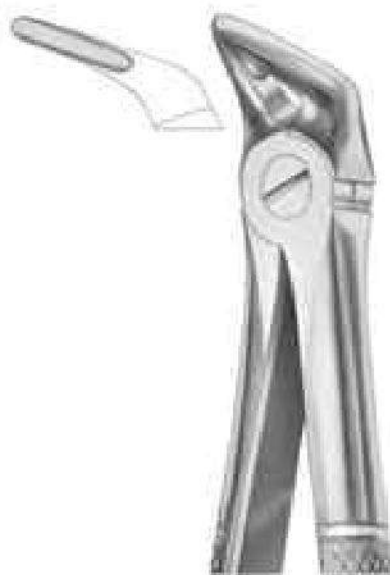

1026
Fig 31
lower roots



1027
Fig 32
lower molars

Extracting Forceps "English Pattern"



1029
Fig 33
lower roots



1030
Fig 33A
lower roots



1031
Fig 33B
lower roots



1032
Fig 33L
lower roots



1033
Fig 37
upper incisors
for children



1034
Fig 33S
lower roots
for children

Extracting Forceps “English Pattern”



1035
Fig 38
lower incisors &
canines for children



1036
Fig 39
upper molars
right for children



1037
Fig 39R
upper molars
right for children



1038
Fig 39A
upper molars
for children



1039
Fig 40
lower molars
for children



1040
Fig 39L
upper molars left
for children

Extracting Forceps “English Pattern”



1041
Fig 41
upper roots



1042
Fig 44
upper roots



1043
Fig 45
upper roots

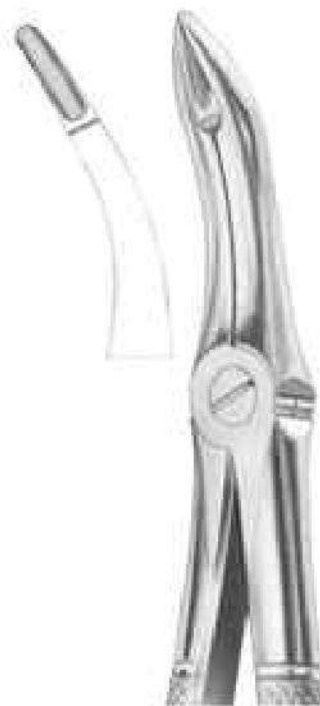

1044
Fig 45
lower roots



1045
Fig 49
upper roots



1046
Fig 50
upper roots

Extracting Forceps “English Pattern”

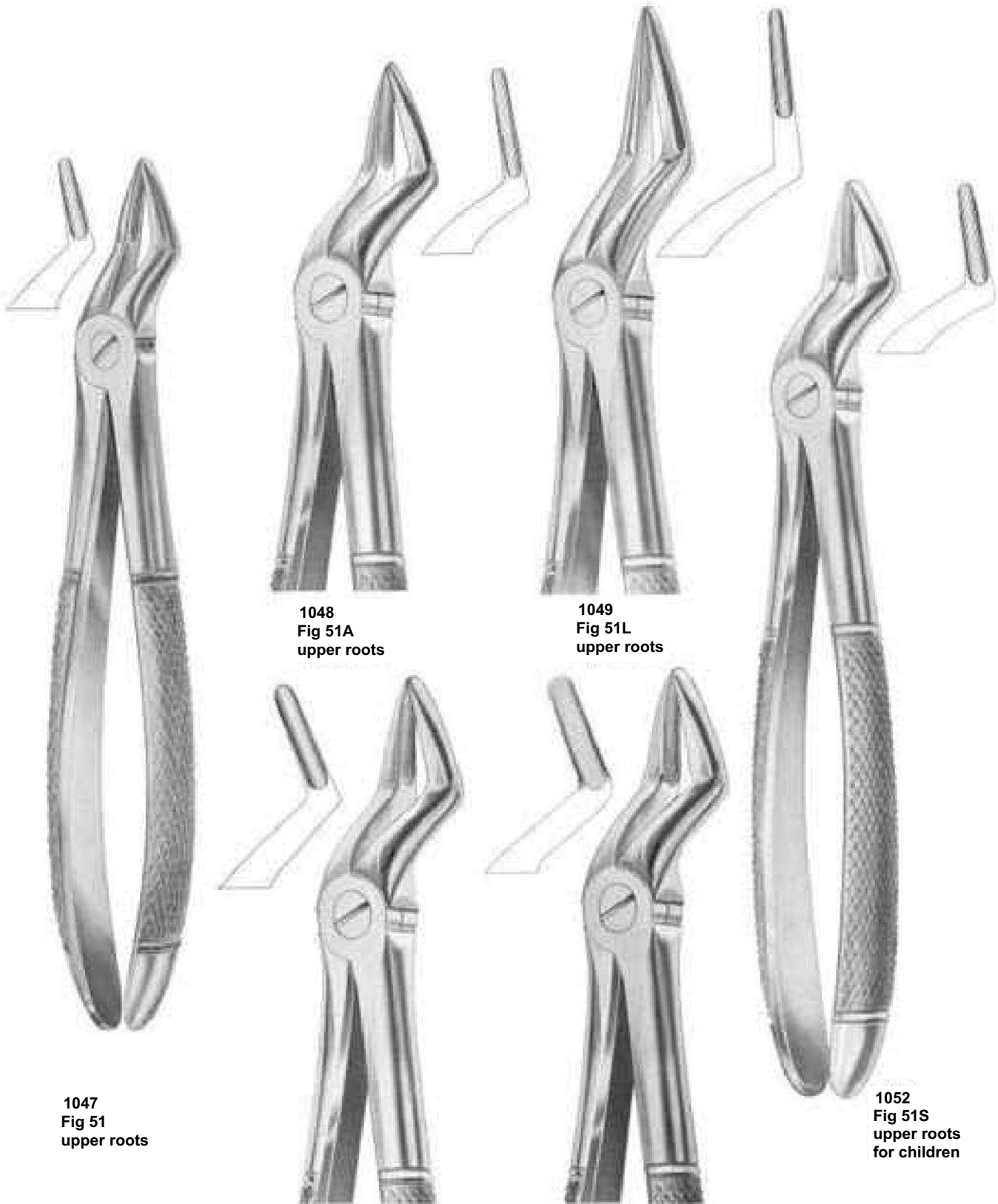

1048
Fig 51A
upper roots

1049
Fig 51L
upper roots

1047
Fig 51
upper roots

1052
Fig 51S
upper roots
for children

1050
Fig 52
upper roots

1051
Fig 52A
upper teeth
and resection

Extracting Forceps “English Pattern”



1053
Fig 54
for separating
upper molars



1054
Fig 55
for separating
upper molars



1055
Fig 56
for separating
lower molars

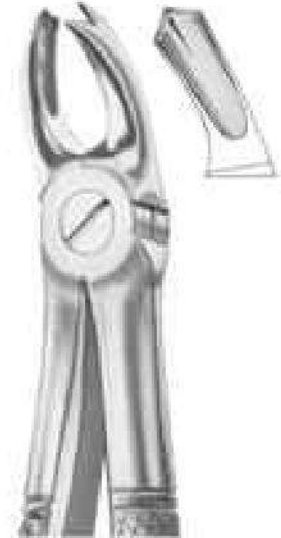

1056
Fig 65R
upper molars
right

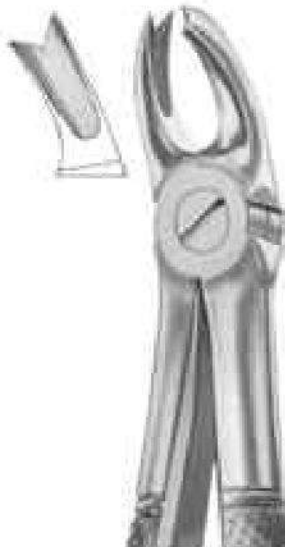

1057
Fig 65L
upper molars left



1058
Fig 67
upper third molars

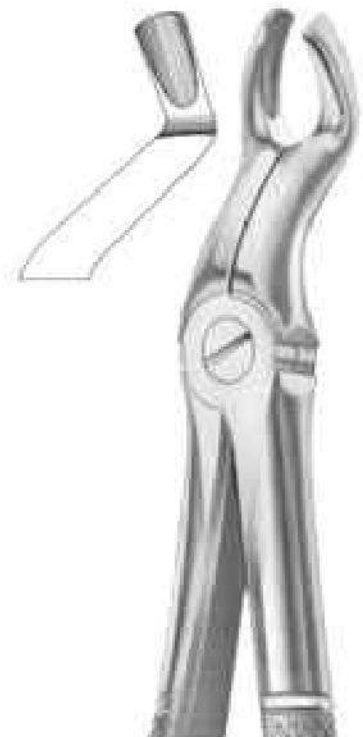

1059
Fig 67A
upper third molars

Extracting Forceps “English Pattern”



1060
Fig 67 1/2 R
upper third molars
right



1061
Fig 67 1/2 L
upper third molars
left



1062
Fig 68
lower roots



1063
Fig 68A
lower roots



1064
Fig 73
lower molars



1065
Fig 73R
lower molars right

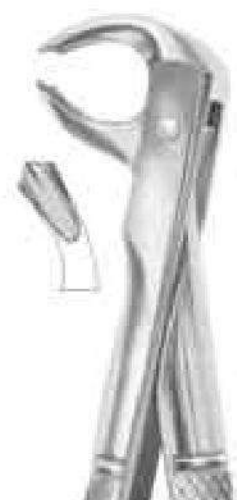

1066
Fig 73L
lower molars left

Extracting Forceps “English Pattern”



1067
Fig 73A
lower molars



1068
Fig 73S
lower molars



1069
Fig 73B
lower molars for children

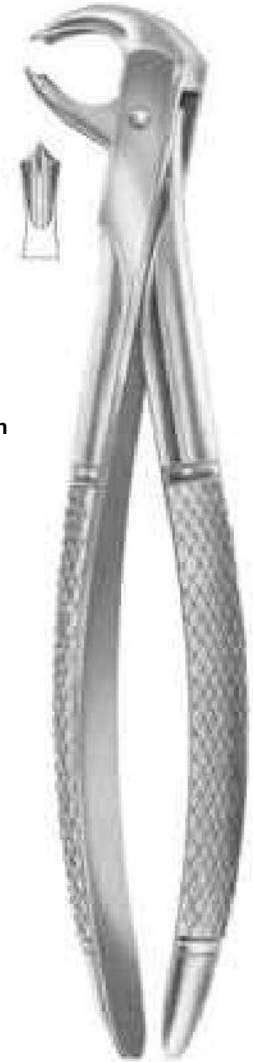

1072
Fig 73R
lower molars
for children



1070
Fig 74
lower roots



1071
Fig 74D
lower roots

Extracting Forceps “English Pattern”



1073
Fig 74M
lower roots



1074
Fig 74N
lower roots



1075
Fig 74XN
lower roots and
crowded incisors



1076
Fig 75
lower
premolars



1077
Fig 76
upper roots



1078
Fig 76N
upper roots

Extracting Forceps “English Pattern”



1079
Fig 76S
upper roots



1080
Fig 79
lower third molars



1081
Fig 79A
lower third molars



1082
Fig 81
lower
premolars and
roots

Extracting Forceps “English Pattern”



1083
Fig 86A
lower molars



1084
Fig 86B
lower molars



1085
Fig 86C
lower molars



1086
Fig 87
lower molars



1087
Fig 91
for separating
lower molars



1088
Fig 99
lower molars

Extracting Forceps “English Pattern”



1089
Fig 101
upper
premolars and
roots



1090
Fig 100
upper roots



1091
Fig 99 1/4
lower molars



1092
Fig 99 1/2
lower molars

Extracting Forceps “English Pattern”



1093
Fig 102
upper molars right



1094
Fig 103
upper molars left



1097
Fig 103
upper canines



1095
Fig 105
lower incisors



1096
Fig 106
lower incisors

Extracting Forceps “English Pattern”



1098
Fig 112
upper roots

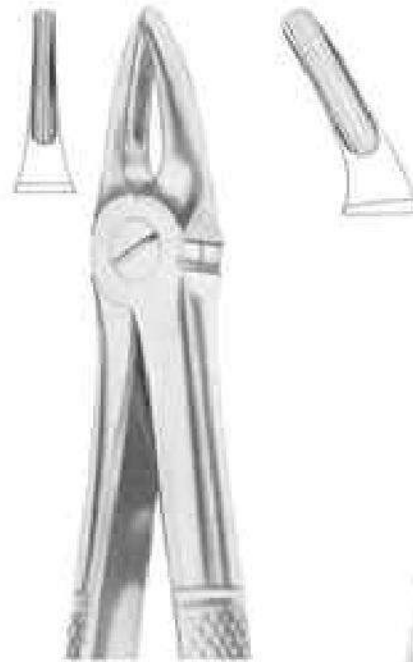

1099
Fig 113
upper roots



1101
Fig 136
upper
premolars and
roots



1102
Fig 137
lower incisors
and roots



1100
Fig 114
upper roots



1103
Fig 143
lower roots

Extracting Forceps “English Pattern”



1104
MEAD (MD 1)
upper anteriors
roots, incisors, canines



1105
MEAD (MD 2)
upper molars



1106
MEAD (MD
3) lower
roots



1107
MEAD (MD
4) lower
molars



1108
FELSCH (Fig 210)
upper third molars

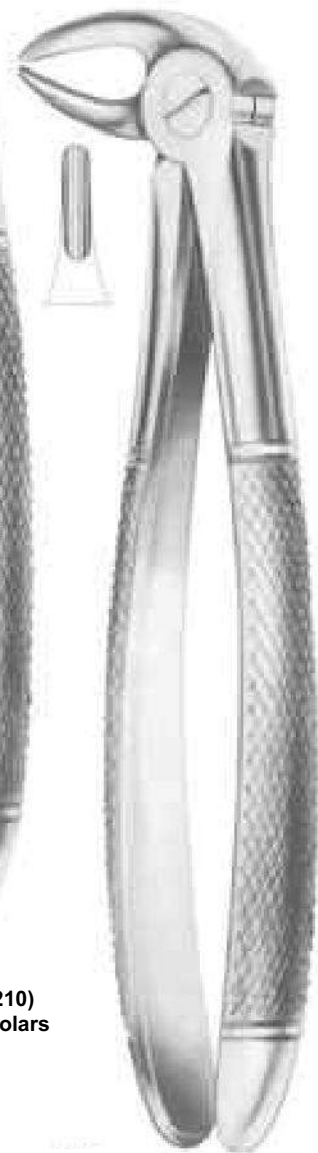

1109
HERTZ (Fig
211) lower
incisors



Wisdom Extracting Forceps



1110
ROUTURIER Fig 212
22 1/2 L
lower molars
and wisdom left



1111
ROUTURIER Fig 213
22 1/2 R
lower molars
and wisdom right



1112
ROUTURIER Fig 214
22 1/2 L
lower molars
and wisdom left



1113
ROUTURIER Fig 215
33 1/2 R
lower molars
and wisdom right



1114
RESECTION FORCEPS
(216/Witzel)
upper roots



Extracting Forceps "English Pattern"



1115
Fig. 5



1116
Fig. 6

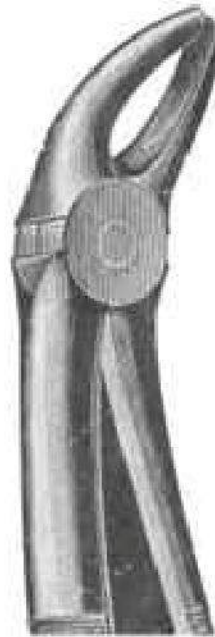

1117
Fig. 9



1118
Fig. 10



1119
Fig. 11



1120
Fig. 12



1121
Fig. 14



1122
Fig. 15



Extracting Forceps "English Pattern"



1123
Fig. 25



1124
Fig. 26



1125
Fig. 27



1126
Fig. 28



1127
Fig. 34



1128
Fig. 35



1129
Fig. 42



1130
Fig. 43



Extracting Forceps "English Pattern"



1131
Fig. 44A

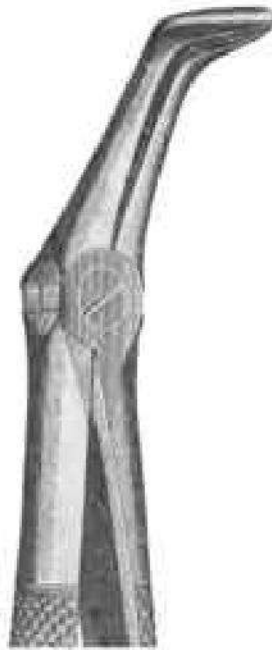

1132
Fig. 46



1133
Fig. 47



1134
Fig. 50A



1135
Fig. 74R



1136
Fig. 74L



1137
Fig. 75R



1138
Fig. 75L



Extracting Forceps "English Pattern"



1139
Fig. 94



1140
Fig. 95



1141
Fig. 98



1142
Fig. 105



1143
Fig. 106



1144
Fig. 2002



Extracting Forceps "With Fitting Handle"



1145
Fig. 1
upper
laterals and
canines



1146
Fig. 2
upper
laterals and
canines



1147
Fig. 3
upper
laterals and
canines



1148
Fig. 4
lower incisors
and canines



1149
Fig. 7
upper
premolars



1150
Fig. 13
lower
premolars



1151
Fig. 13S
lower
premolars for
children



Extracting Forceps "With Fitting Handle"



1152
Fig. 17
upper molars right



1153
Fig. 18
upper molars left



1154
Fig. 18A
upper molars



1155
Fig. 18B
upper molars



1156
Fig. 19
upper third molars



1157
Fig. 22
lower molars



1158
Fig. 22S
lower molars
for children



Extracting Forceps "With Fitting Handle"



1159
Fig. 29
upper roots



1160
Fig. 20S
upper roots
for children



1161
Fig. 30
upper roots

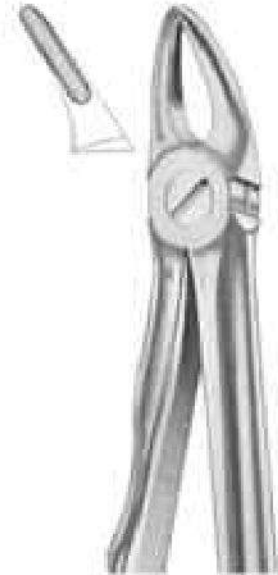

1162
Fig. 30S
upper roots
for children



1163
Fig. 33
lower roots



1164
Fig. 33A
lower roots



1165
Fig. 33B
lower roots



Extracting Forceps "With Fitting Handle"



1166
Fig. 33L
lower roots



1167
Fig. 33S
lower roots
for children



1168
Fig. 37
upper incisors
for children



1169
Fig. 39L
upper incisors
for children



1170
Fig. 39A
upper molars
for children



1171
Fig. 39R
upper molars right
for children



1172
Fig. 39L
upper molars left
for children



Extracting Forceps "With Fitting Handle"



1173
Fig. 41
upper roots

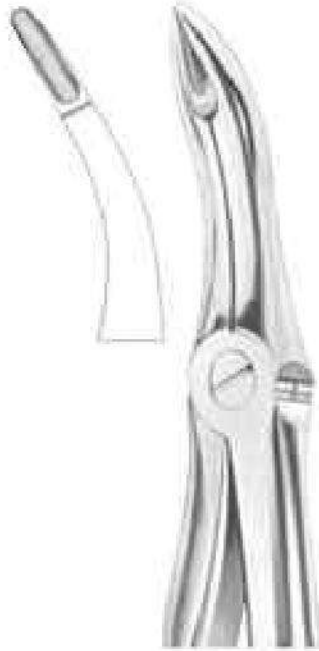

1174
Fig. 44
upper roots



1175
Fig. 45
lower roots

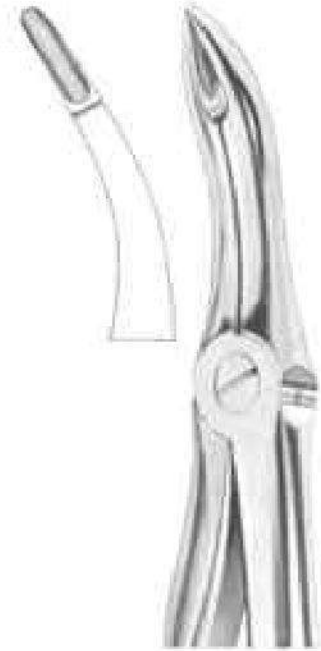

1176
Fig. 48
lower roots



1177
Fig. 51
upper roots



1178
Fig. 51A
upper roots

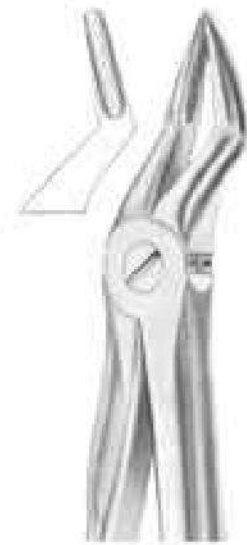

1179
Fig. 51S
upper roots
for children



Extracting Forceps "With Fitting Handle"



1180
Fig. 51L
upper roots

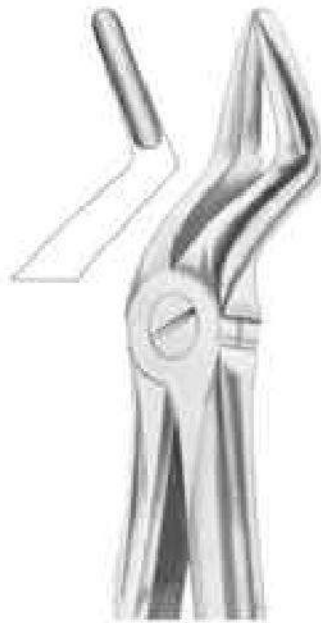

1181
Fig. 52
upper roots



1182
Fig. 54
for separating
upper molars

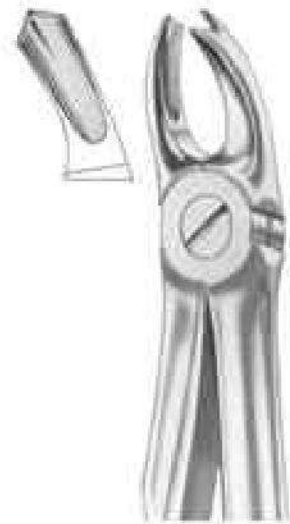

1183
Fig. 65R
upper molars right

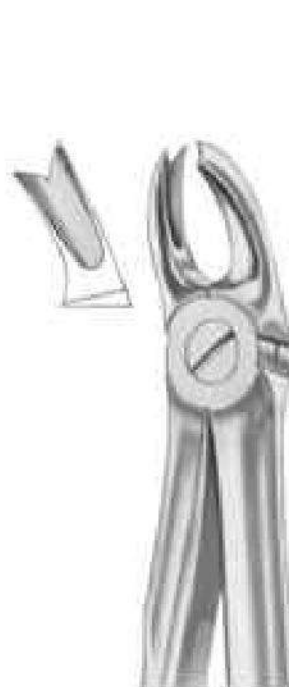

1184
Fig. 65L
upper molars left



1185
Fig. 67
upper third molars

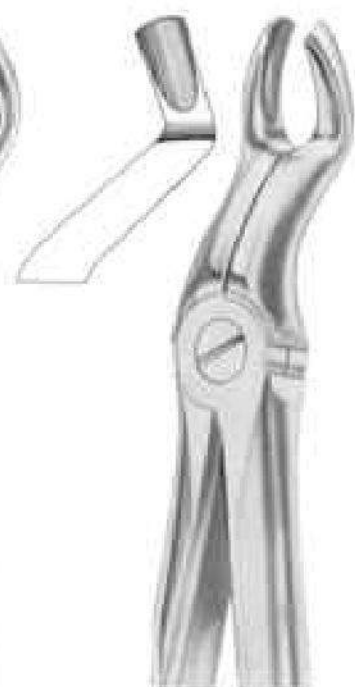

1186
Fig. 67A
upper third molars



Extracting Forceps "With Fitting Handle"



1187
Fig. 67 1/2 R
upper third molars
right

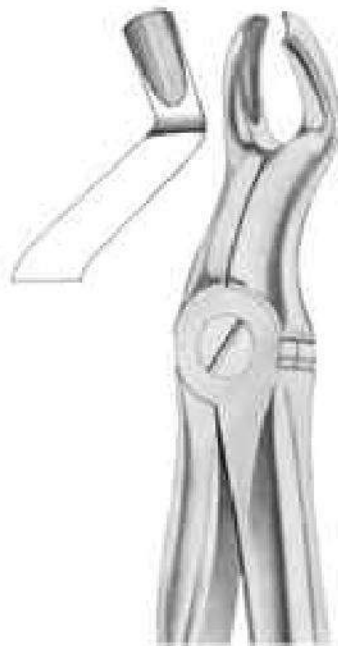

1188
Fig. 67 1/2 L
upper third molars
left

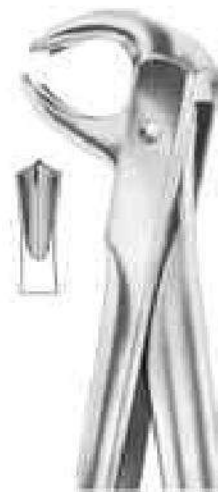

1188
Fig. 73
lower molars



1190
Fig. 74
lower roots



1191
Fig. 74M
lower roots



1192
Fig. 74N
lower roots



1193
Fig. 74XN
lower roots and
crowded incisors



Extracting Forceps "With Fitting Handle"



1194
Fig. 75
lower
premolars



1195
Fig. 76
upper roots



1196
Fig. 76N
upper roots



1197
Fig. 81
lower
premolars and
roots



1198
Fig. 76A
lower third molars



1199
Fig. 79
lower third molars



Extracting Forceps "With Fitting Handle"



1200
Fig. 86A
lower molars



1201
Fig. 86B
lower molars



1202
Fig. 86C
lower molars



1203
Fig. 99
lower molars



1204
Fig. 99 1/4
lower molars



1205
Fig. 136
upper
premolars and
roots



1206
Fig. 143
lower roots



Extracting Forceps "For Children"



1207
KLEIN (Fig 217)
upper incisors

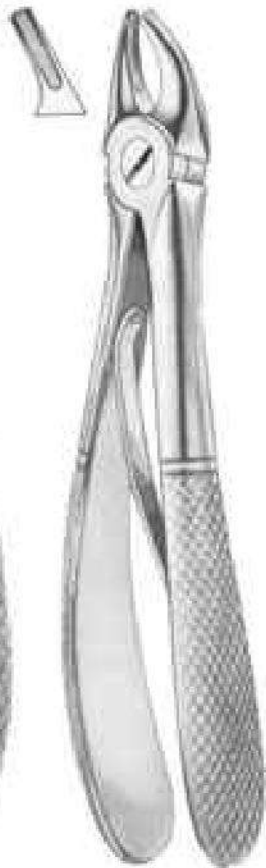

1208
KLEIN (Fig 218)
upper premolars



1209
KLEIN (Fig 219)
upper roots



1210
KLEIN (Fig 220)
upper molars



1214
ALBRECH
T Fig. 224
Deciduous



1215
ALBRECH
T Fig. 225
Deciduous



1211
KLEIN (Fig 221)
lower incisors



1212
KLEIN (Fig 222)
lower molars



1213
KLEIN (Fig 223)
lower roots



Root Splinter Forceps

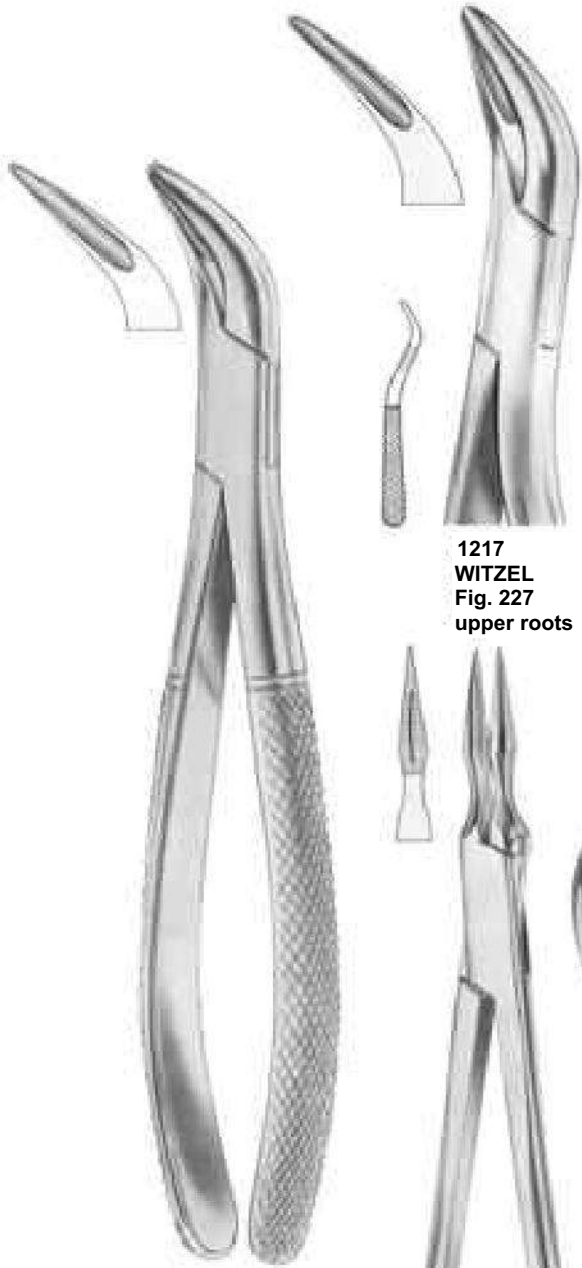

1217
WITZEL
Fig. 227
upper roots

1216
WITZEL
Fig. 226
lower roots



1218 ARTHUR
Fig. 228
root
fragments



1219
STIEGLITZ
Fig. 229
root fragments

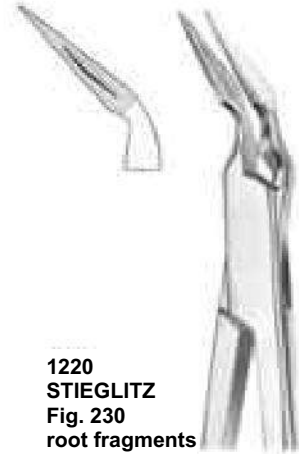

1220
STIEGLITZ
Fig. 230
root fragments



1221 RALK
Fig. 231
root
fragments



Extracting Forceps "American Pattern"



1222
W1.WINTER
upper
centrals and
canines



1223
Fig. 1
upper and lower roots

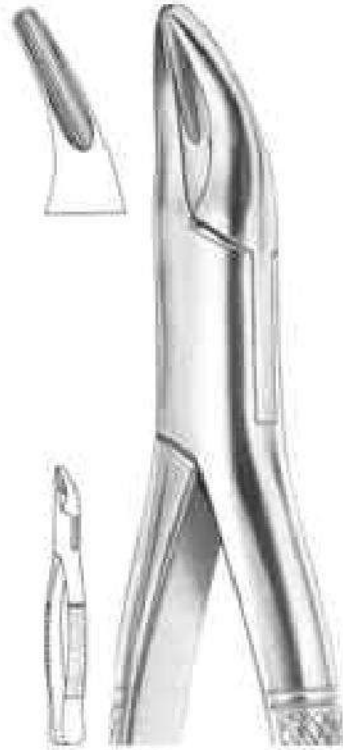

1224
Fig. 2
upper and lower roots



1225
Fig. 4
upper and lower premolars



1226 PHYSICK
Fig. 5
lower third molars



1227
Fig. 6
separating
forceps



Extracting Forceps "American Pattern"



1228
Fig. 7
upper roots

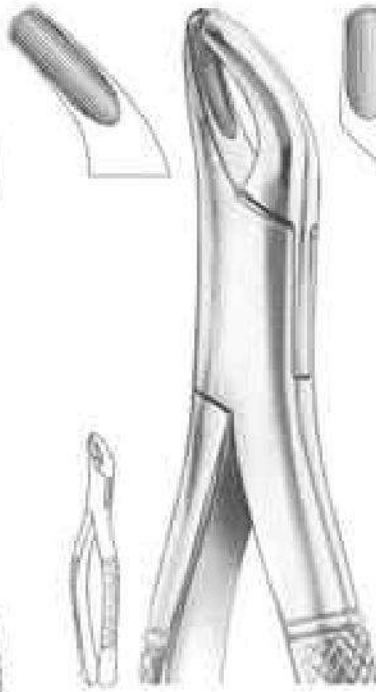

1229
Fig. 8
upper and lower
third molars



1231
Fig. 10H
upper molars



1232
Fig. 13
upper incisors



1230
Fig. 10S
upper molars



1233
Fig. 14
lower incisors



Extracting Forceps "American Pattern"

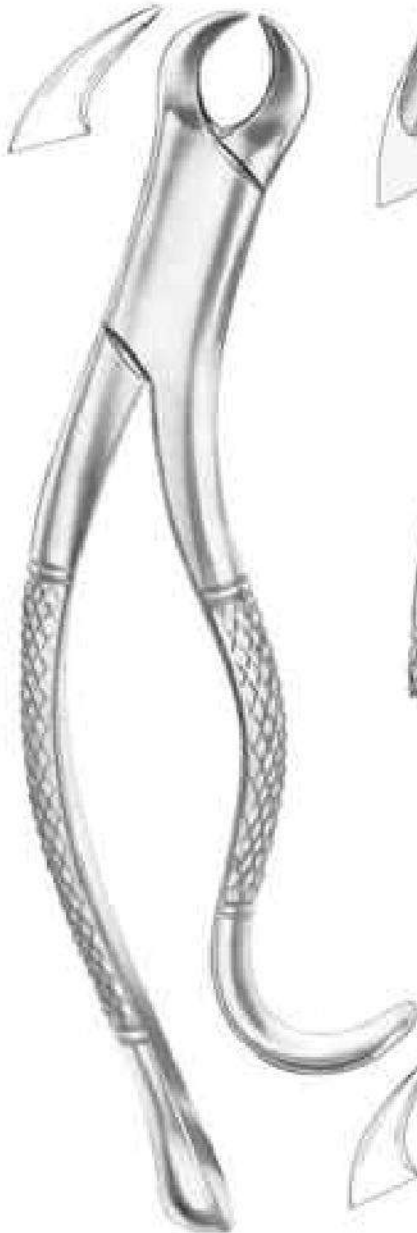

1234
Fig. 16
lower molars



1235
HARRIS
Fig. 15
lower molars

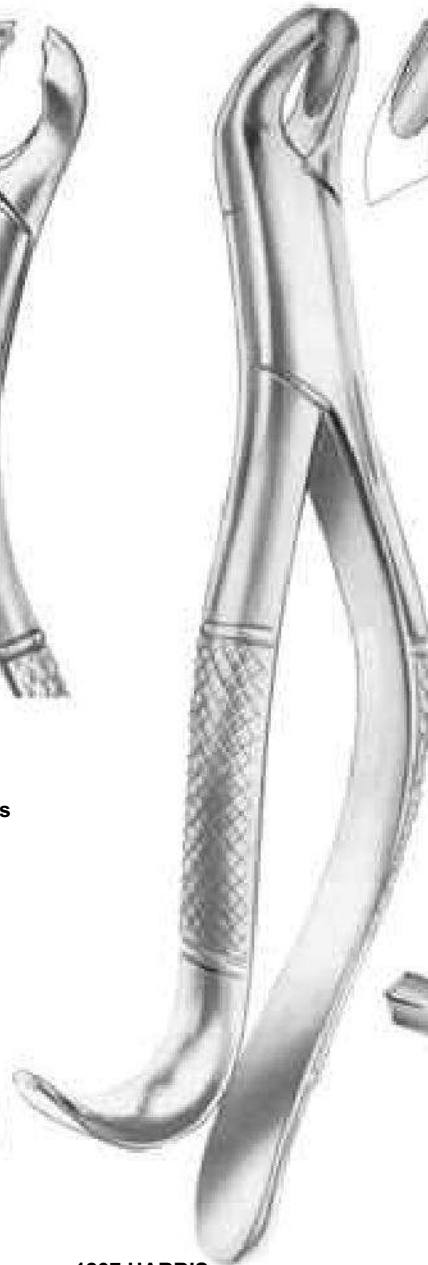

1237 HARRIS
Fig. 18R
upper molars right



1238 HARRIS
Fig. 18L
upper molars left



1236
Fig. 16S
lower molars
for children



1239
Fig. 17
lower molars



Extracting Forceps "American Pattern"

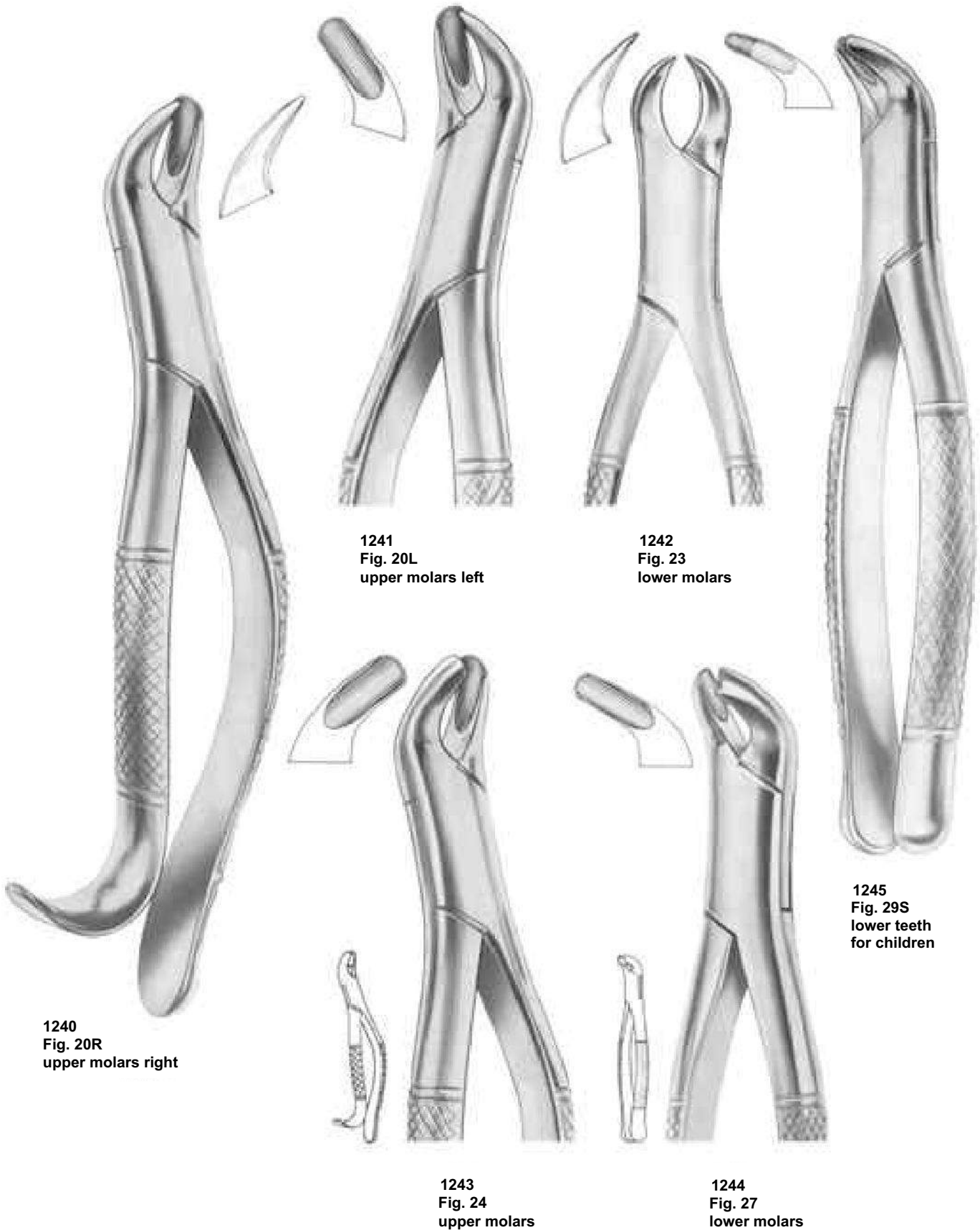



Extracting Forceps "American Pattern"



1246
Fig. 30S
upper teeth
for children



1247 PARMLY
Fig. 32
upper
premolars and
molars



1248 PARMLY
Fig. 32A
upper
premolars and
roots



1249
Fig. 34
lower anteriors
and roots



1250
Fig. 35
upper roots



1251
Fig. 36
lower anteriors
and roots



Extracting Forceps "American Pattern"



1252
Fig. 37
lower anteriors
and roots



1255
Fig. 53L
upper molars let



1253
Fig. 38
upper anteriors
and roots

1254
Fig. 53R
upper molars right



1256
Fig. 62
incisors, premolars,
deciduous teeth



1257
Fig. 65
upper incisors
and roots



Extracting Forceps "American Pattern"



1258 TOMES
Fig. 69
upper and lower roots



1259 TOMES
Fig. 85
lower canines
premolars and
molars

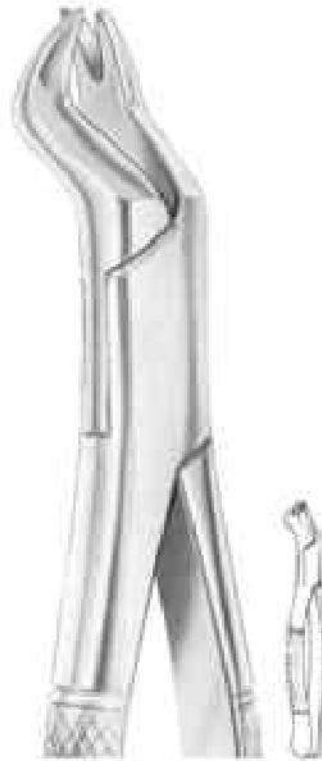

1260 NEVIUS
Fig. 88R
upper molars right



1261 THOMAS
Fig. 85A
lower children
premolars and
molars



1262 NEVIUS
Fig. 88L
upper molars left



Extracting Forceps "American Pattern"



1263 KELLS
Fig. 99A
upper incisors,
canines,
premolars



1264
Fig. 104
upper third molars



1266 HULL
Fig. 101
deciduous teeth



1267
Fig. 103
lower incisors,
premolars

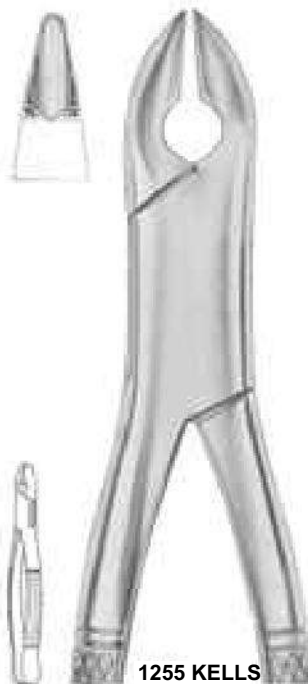

1255 KELLS
Fig. 99C
upper incisors,
canines,
premolars



Extracting Forceps "American Pattern"



1268 CRYER
Fig. 150
lower incisors
premolars,
roots



1269 CRYER
Fig. 150A
upper incisors
premolars,
roots



1271 CRYER
Fig. 151
lower incisors
premolars,
roots



1272 CRYER
Fig. 150A
lower incisors
premolars,
roots



1270 CRYER
Fig. 150S
upper teeth for children



1273 CRYER
Fig. 151S
lower teeth for children



Extracting Forceps "American Pattern"



1274
Fig. 203
lower incisors,
and roots



1275
Fig. 210S
upper third molars



1277
Fig. 210H
upper third molars



1278
Fig. 213
upper centrals and canines



1276
Fig. 201
upper incisors,
canines,
premolars

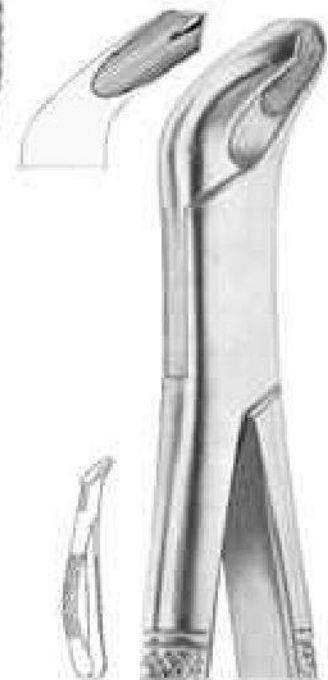

1279
Fig. 217
lower molars



Extracting Forceps "American Pattern"



1280
Fig. 222
lower third molars



1282
Fig. 286
swing lower molars



1283
Fig. 288
lower canines
and
premolars



1281
Fig. 286
upper incisors and roots



Extracting Forceps "American Pattern"



1284 COHEN
Fig. 310
universal
forceps

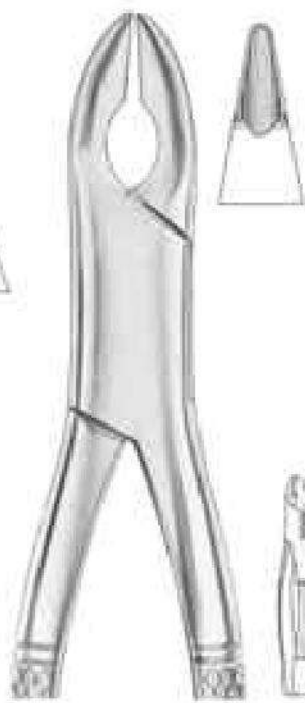

1285 NEVIUS
Fig. 320/10S
upper canines

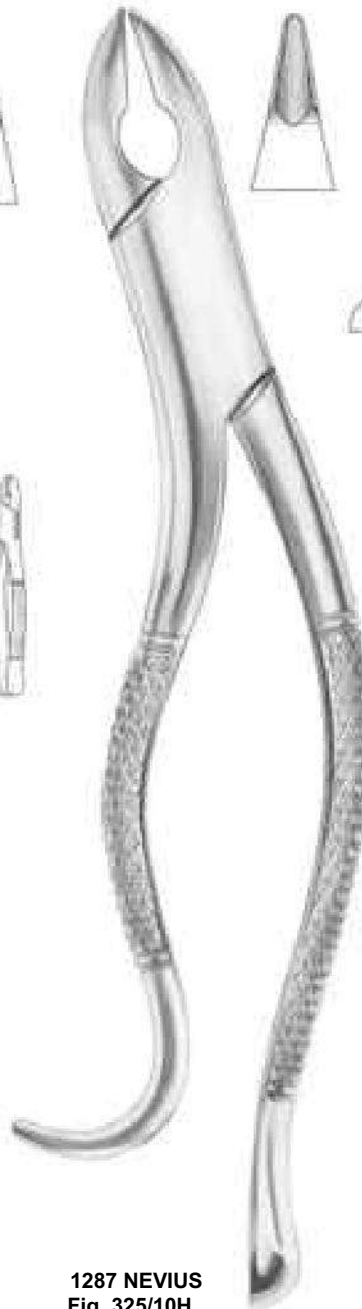

1287 NEVIUS
Fig. 325/10H
upper canines



1286 HENAHAN
Fig. 315/1A
upper incisors



1288 STANDARD
Fig. 330/4
upper third molars



Extracting Forceps "American Pattern"



1289
WOODWAR
D Fig.
335/FH lower
molars



1290
Fig. 340/89
upper molars right



1292
Fig. 345/90
upper molars left

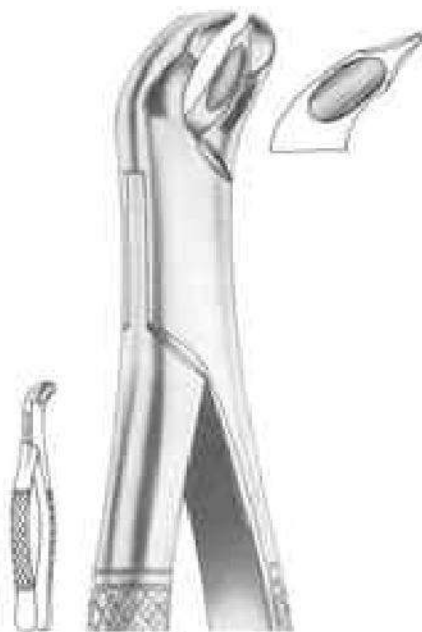

1291
WOODWAR
D Fig.
335/FS lower
molars



Extracting Forceps "American Pattern"

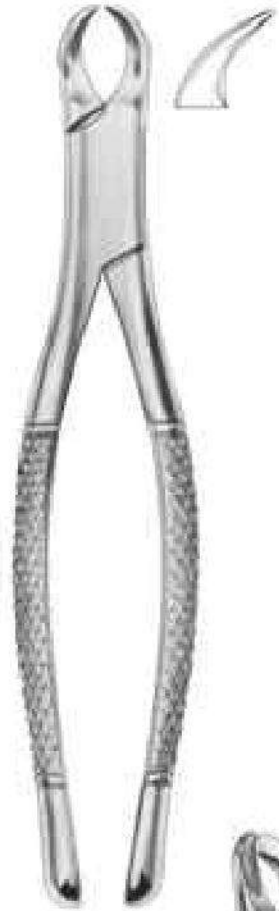

1293
Fig. 350/23S
lower molars

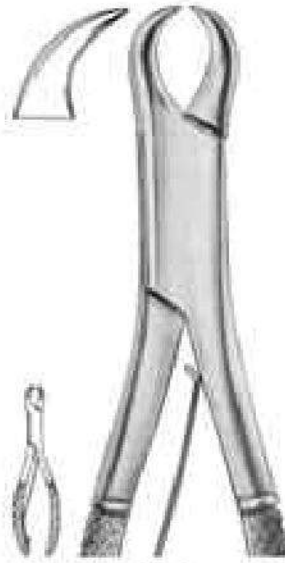

1294
Fig. 355/23SK
lower molars



1295
Forcep Fig. 301



1295-A
Forcep Fig. 300



1296
Fig. 360/17SK
lower molars



1297
Fig.
360/150SK
upper interiors
and roots



1298
Fig.
370/151SK
lower interiors
and roots



Peristeel Elevators



1299
Molt 9

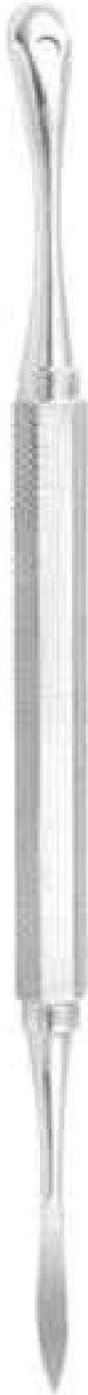

1300
Allen 9A



1301
Prichard



1302
Seldin



1303
Goldman Fox 14



1304
West
Dell W2



Elevators

Heidbrink Root - Tip Picks

Root Tip



1305
DEL 78



1306
DEL 79



1307
DEL 80



1308
DEL H1



1309
DEL H2



1310
DEL H3



1311
DEL H2-3



1312
POTT
6X



1313
POTT
7X



Periosteal Elevators



1314
BUSER



1315
OHI 10



1316
HOWARD 9H



1317
FREER

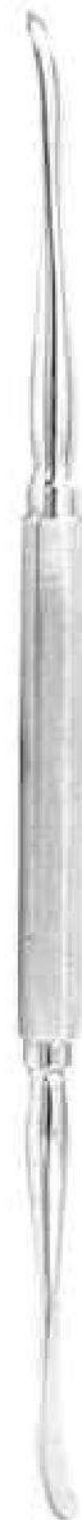

1318
FREER 15



1319
FREER 16



Root Elevators

lower jaw, left side

lower jaw, right side



**1320
BEIN
N
Fig 4**



1331



1332

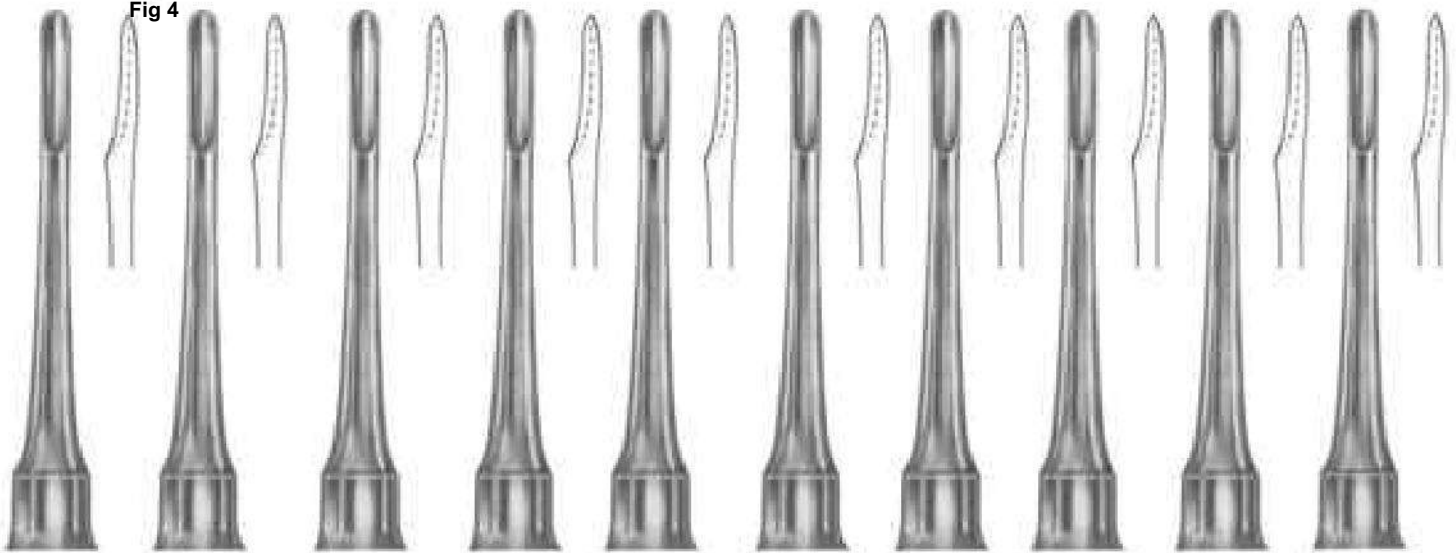

**1321
BEIN
1.0
mm**

**1322
BEIN
1.5
mm**

**1323
BEIN
2.0
mm**

**1324
BEIN
2.5
mm**

**1325
BEIN
3.0
mm**

**1326
BEIN
3.5
mm**

**1327
BEIN
4.0
mm**

**1328
BEIN
4.5
mm**

**1329
BEIN
5.0
mm**

**1330
BEIN
5.5
mm**



Root Elevators



**1333
BEIN**



**1334
BEIN
Fig. 1**



**1335
BEIN
Fig. 2**



**1336
BEIN
Fig. 0**



**1337
BEIN
Fig. 3**



**1338
BEIN
Fig. 4**



**1339
BEIN
Fig. 5**



**1340
BEIN
Fig. 6**



Root Elevators



**1341
CRYE
R Fig.
3**



**1342
CRYE
R Fig.
4**



**1343
CRYE
R Fig.
12**



**1344
CRYE
R Fig.
27**



**1345
CRYE
R Fig.
28**



**1346
CRYER
Fig. 27S**



**1347
CRYER
Fig. 28S**



**1348
SELDIN
Fig. 2**



**1349
SELDIN
Fig. 3**



**1350
SELDIN
Fig. 4L**



**1351
SELDIN
Fig. 4R**



**1352
SELDIN
Fig. 1L**



**1353
SELDIN
Fig. 1R**



Swa Elevators & Root Screws



1354



1355



1356



1357



1358



1359



1360

ROOT SCREWS



1362
Morrison
2.0 mm



1363
Morrison
2.5 mm



1364
Morrison
3.0 mm



1361
Morrison
3.5 mm



Root Elevators



1365
IS-APICAL



1366
APICAL
2 mm
Fig. 1



1367
APICAL
3 mm
Fig. 2



1368
APICAL
4 mm
Fig. 3



1369
APICAL
4.5 mm
Fig. 4



1370
APICAL
2 mm
Fig. 5



1371
APICAL
3 mm
Fig. 6



1372
APICAL
4 mm
Fig. 7



1373
APICAL
4.5mm
Fig. 8



1374
APICAL
Fig. 9



1375
WINTER
Fig. 14L



1376
WINTER
Fig. 14R



1377
HEIDBRIN
K Fig. 1



1378
HEIDBRIN
K Fig. 2



1379
FLOHR
Fig. 1



1380
FLOHR
Fig. 2



1381
APICAL
Fig. 1



1382
APICAL
Fig. 2



Root Elevators



1383
IS-CRYER



1384
CRYE
R Fig.
1



1385
CRYE
R Fig.
2



1386
IS-COUPLAND



1387
COUPLAN
D Fig. 1



1388
COUPLAN
D Fig. 2



1389
COUPLAN
D Fig. 3



Root Elevators



1390
Fig. 1



1391
Fig. 2



1392
Fig. 3



1393
FLOHR
Fig. 1



1394
FLOHR
Fig. 2



1395
FLOHR
Fig. 3



Root Elevators



1396
KOPP
Fig. 1



1397
KOPP
Fig. 2



1403
KOPP
Fig. 1



1404
KOPP
Fig. 2



1396
KOPP



1398
KOPP
Fig. 3



1399
KOPP
Fig. 4



1402
KOPP



1405
KOPP
Fig. 4



1406
KOPP
Fig. 4



1400
KOPP
Fig. 5



1401
KOPP
Fig. 6



Root Elevators



**1407
HYLIN**



**1407
HYLIN
Fig. 1**



**1408
HYLIN
Fig. 2**



**1409
BEIN**

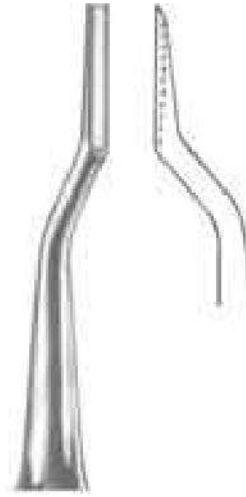

**1409
BEIN
Fig. 1**

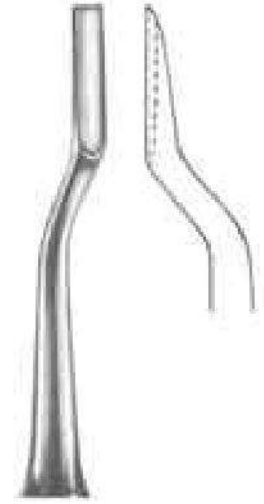

**1410
BEIN
Fig. 2**



**1411
BEIN
Fig. 3**

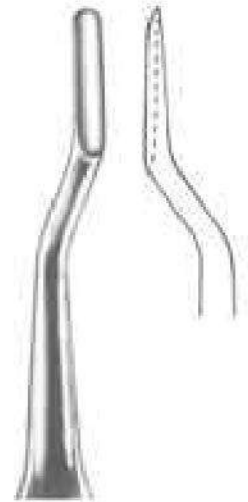

**1412
BEIN
Fig. 4**



Root Elevators

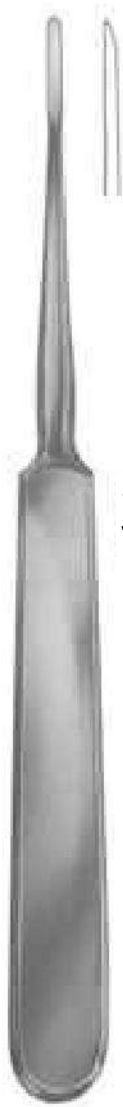

1413 Warwick-James Fig. 1



1413 Warwick-James Fig. 2



1414 Warwick-James Fig. 3

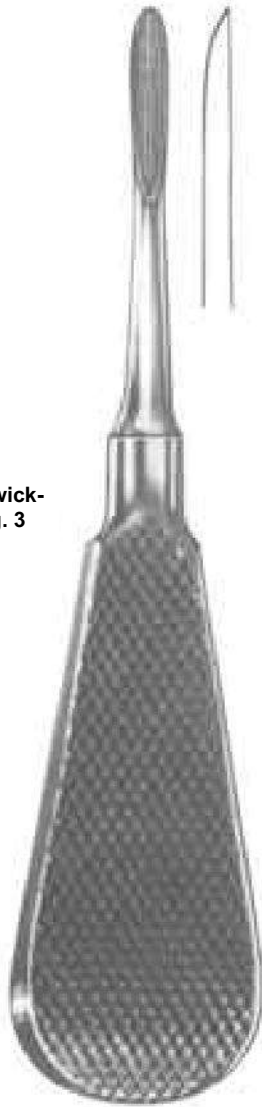

1415 London Hospital Fig. 1



1415 London-Hospital Fig. 2



1416 London-Hospital Fig. 3



1417 OTT



Root Elevators



1418
CHOMPRE
T Fig. 1



1419
CHOMPRE
T Fig. 2



1420
CHOMPRE
T Fig. 3



1421
CHOMPRE
T Fig. 4



1423
Fig. 1



1422
Fig. 1

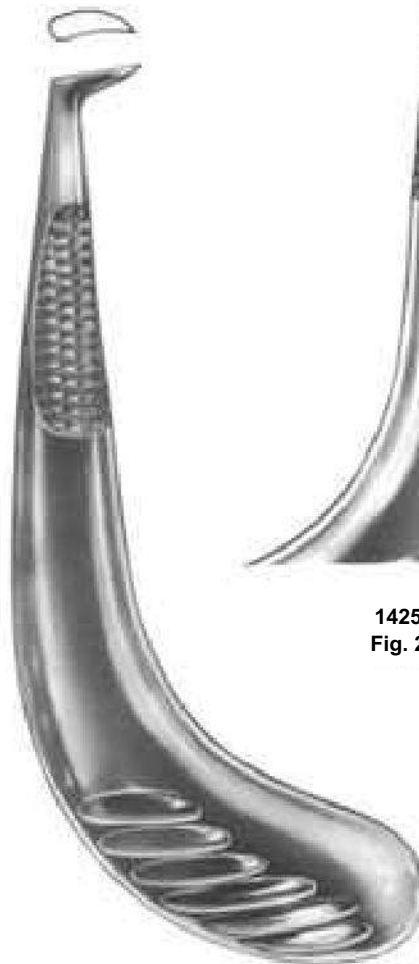

1424
Fig. 1



1425
Fig. 2



1426
APICAL



Root Tip Elevators



1427
IS-Fig. 1



1428
Fig. 2



1429
Fig. 3



1430
HEIDBRIN
K Fig. 1



1431
HEIDBRIN
K Fig. 2



1432
HEIDBRIN
K Fig. 3



1438
MEA
D
MD1



1433
LECLUSE



1434
MEAD
MD-
5A



1435
MEAD
MD-
6A



1436
MEAD
MD-
7A



1437
MEA
D MD-
8



Root Elevators



1439
WINTER
Fig. 1L



1440
WINTER
Fig. 1R



1441
WINTER
Fig. 2L



1442
WINTER
Fig. 2R

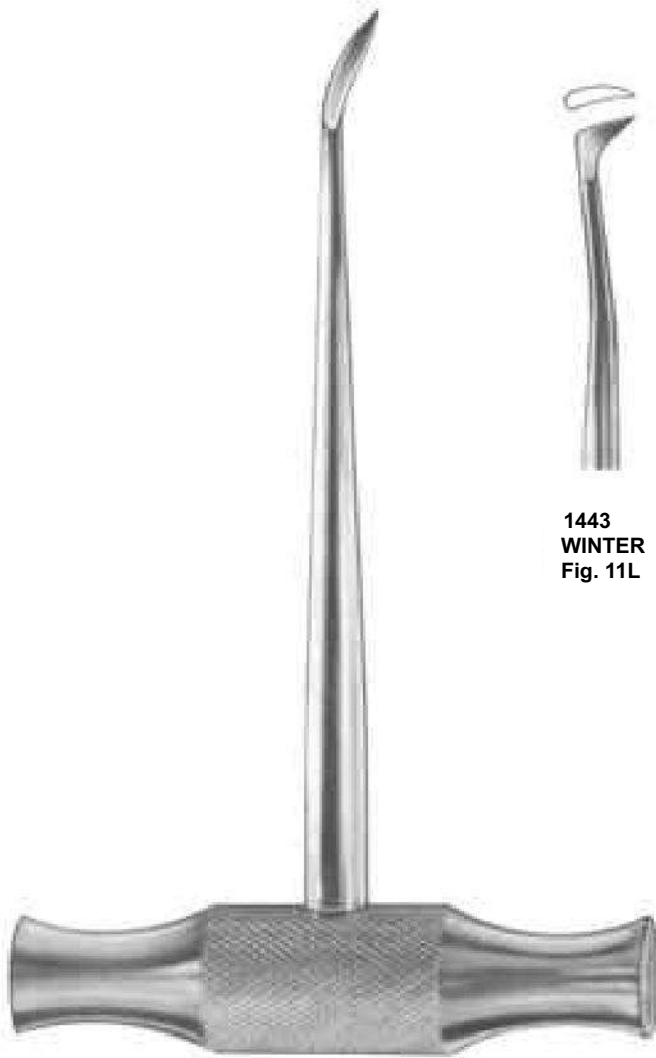

1438
WINTER



1443
WINTER
Fig. 11L



1444
WINTER
Fig. 11R



1445
WINTER
Fig. 12L



1446
WINTER
Fig. 12R



1447
WINTER
Fig. 14L



1448
WINTER
Fig. 14R



Root Elevators



1449
BARRY
Fig. 1



1450
BARRY
Fig. 2



1451
BARRY
Fig. 3



1452
BARRY
Fig. 4



1449
BARRY



1453
BARRY
Fig. 11



1454
BARRY
Fig. 12



1455
BARRY
Fig. 17



1456
BARRY
Fig. 18



Root Elevators



1458
CRYE
R Fig. 26



1459
CRYE
R Fig. 27



1460
CRYE
R Fig. 28



1461
CRYE
R Fig. 29



1462
HEIDBRIN
K Fig. 22



1463
HEIDBRIN
K Fig. 23



1457



Root Elevators



1465
KOPP
Fig. 31



1466
KOPP
Fig. 32



1467
KOPP
Fig. 33



1468
KOPP
Fig. 34



1469
KOPP
Fig. 35



1470
KOPP
Fig. 44



1464



Root Elevators



1472
HEIDBRIN
K Fig. 10



1473
WINTER
Fig. 11



1474
WINTER
Fig. 12



1475
BARRY
Fig. 17



1476
BARRY
Fig. 18



1477
BARRY
Fig. 20



1471

Root Elevators according to Dr. Sader,
with interchangeable working tips

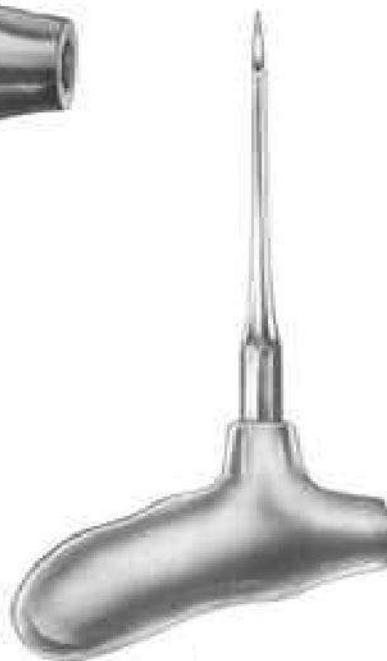

1478



1479



1480



Elevators Plastic Handle

1481

Root Elevator, Plastic Handle, Set of 10 Pcs

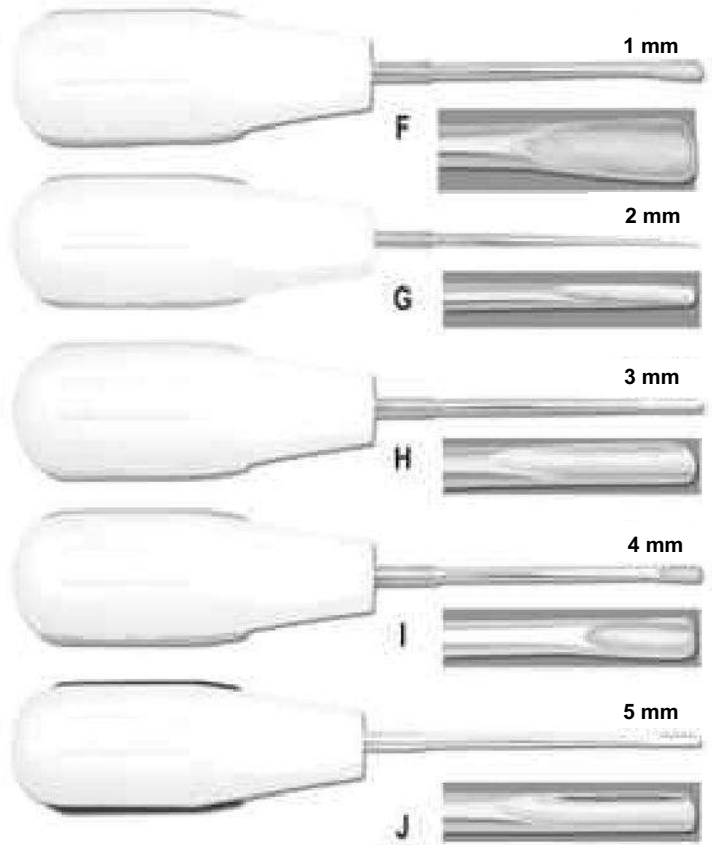
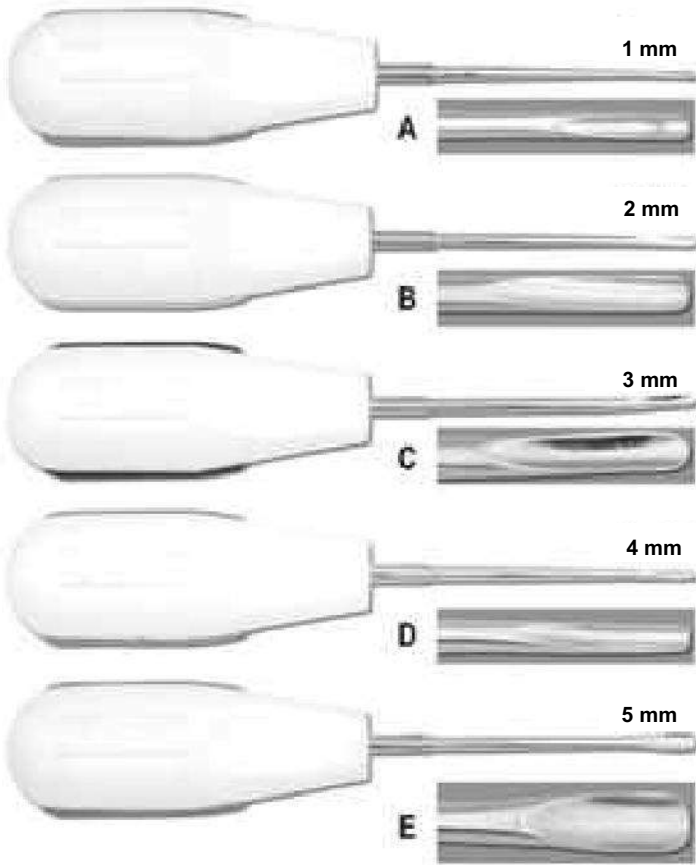

1482

Root Elevator, Plastic Handle, Set of 5 Pcs

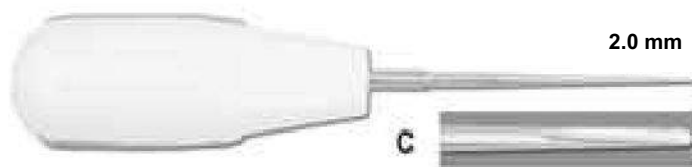
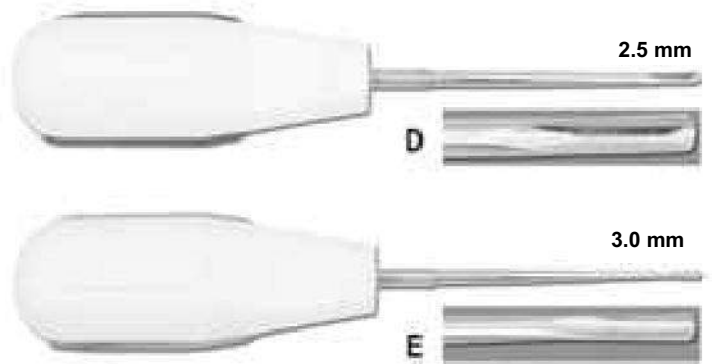
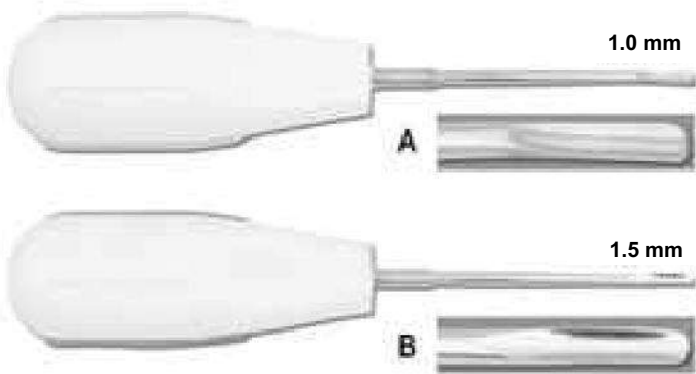

Section - 02



- * Scalpel Handles
- * Mouth Mirrors, Handles
- * Scalers
- * Explorers
- * Probes
- * Condensers
- * Excavators



Scalpel Handles



1483
Scalpel Handle angle of blade adjusts to Easily get around corners
adjustment sets blade from straight to back angled
Locks in at in 90°, 60°, 30°, Straight 30°, 60° angles



1484
Scalpel handle
Fig. 5



1485
Scalpel handle
Curved



1486
Fig. 3L

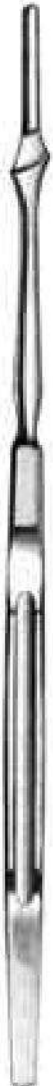

1487
Fig. 7



1488
Scalpel Handle
Fig 4L/ Curved
20 cm



1489
Fig. 3



1490
Fig. 3G



1491
Fig. 4



1492



1493
Scalpel Handle
4 D 14.0 cm



1494
Mess Holders



1495
Gouge
Blade Handle
Fig 2/ 11.5cm



Handles

Handle For mouth Mirrors, Probes, Explorers, Carvers, Curettes # Scalars



1486
Handle No. 2 Standard Single Ended



1497
Handle Single Ended



1498
Handle Single Ended



1499
Handle Single Ended



1500
Octagonal Double Ended



1501
Octagonal Double Ended



1502
Octagonal Double Ended



1503
Handle No. 2 (Standard Double Ended)



1504
Octagonal Double Ended



1505
Tactile Tone Double Ended



1506
Tactile Tone Double Ended



1507
Tactile Tone Double Ended

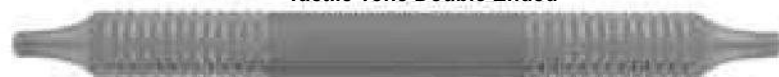

1508
Handle Double Ended



1509
Double Ended



1510
Tactile Tone Double Ended



1511
Tactile Tone Double Ended



Handles & Mouth Mirrors

Mouth Mirrors, Magnifying 1513-A Plain 1512-B

Fig. 00	∅	8 mm
Fig. 0	∅	10mm
Fig. 1	∅	14 mm
Fig. 2	∅	16 mm
Fig. 3	∅	18 mm
Fig. 4	∅	20 mm
Fig. 5	∅	22 mm
Fig. 6	∅	24 mm
Fig. 7	∅	26 mm
Fig. 8	∅	28 mm
Fig. 9	∅	30 mm
Fig. 10	∅	32 mm

1513-A

Mouth Mirrors

Plane



1514
Fig. 6
∅ 26mm

1515
Fig. 5
∅ 24mm

1516
Fig. 4
22mm

Magnifying



1517
Fig. 6
∅ 26mm

1518
Fig. 5
∅ 24mm

1519
Fig. 4
∅ 22mm

Front surface



1520
Fig. 6
Rhodium
26mm Front
Surface

1521
Fig. 5
Rhodium
24mm Front
Surface

1522
Fig. 4
Rhodium
22mm Front
Surface

Plane



1523
Fig. 6
∅ 26mm

1524
Fig. 5
∅ 24mm

1525
Fig. 4
∅ 22mm

Magnifying



1526
Fig. 6
26mm∅

1527
Fig. 5
∅ 24mm

1528
Fig. 4
∅ 22mm

With Cone Socket

1512
Hollow Handle
Fig. 1

1513
Hollow Handle
Fig. 2



Mirror Handles Mouth Mirrors



1529



1530



1531



1532



1533



1534



1535
Parallelometer
Mouth Mirror

1536
Parallelometer
Mouth Mirror
handle
code 2101



1537
Tactile Tone
Single Ended



1538 Handle
Thompson
Single Ended



1539
Hollow Handle



1540
Hollow Handle
Stainless
Steel



1541
Cone-Socket
Hollow Handle



1542
Hollow Handle



1543
Hollow Handle



Scalers

SCALERS - JAQUETTE

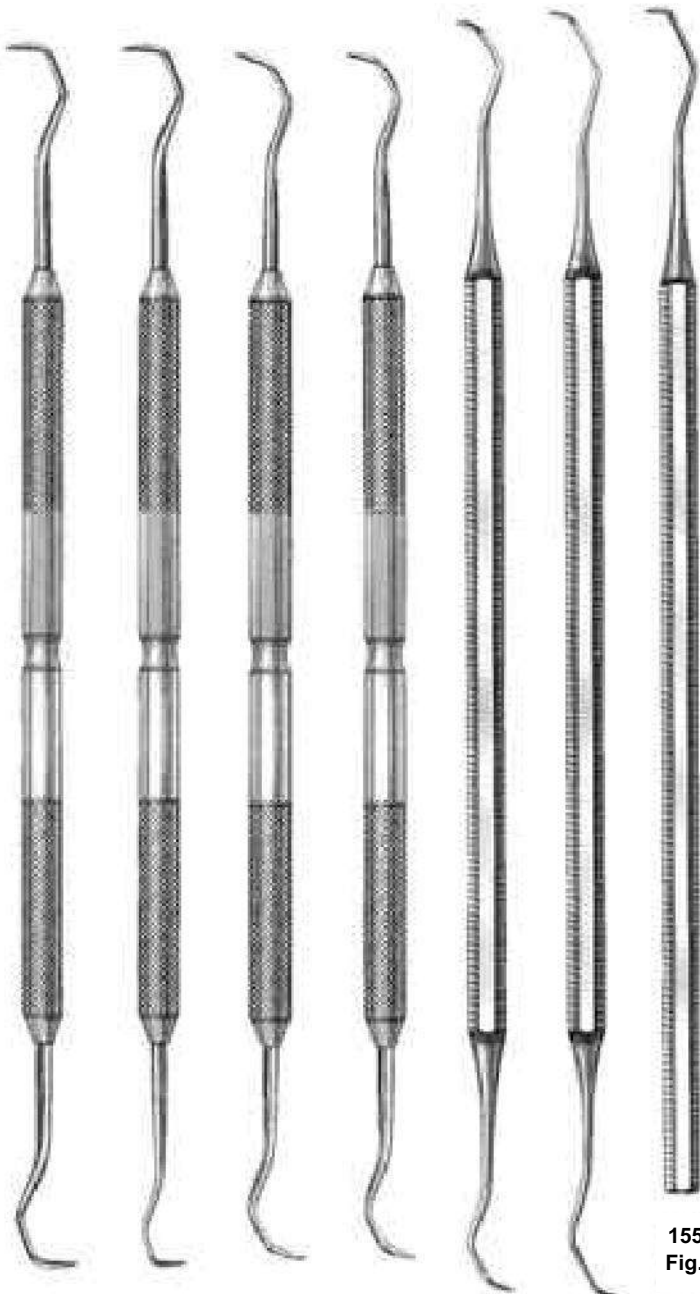

- 1544 1Y-1Y
- 1545 1Y-1YS
- 1546 2Y-3Y
- 1547 2YS-3YS
- 1548 2-3
- 1549 2S-3S

1550
Fig.1

SCALERS - OCTAGONAL

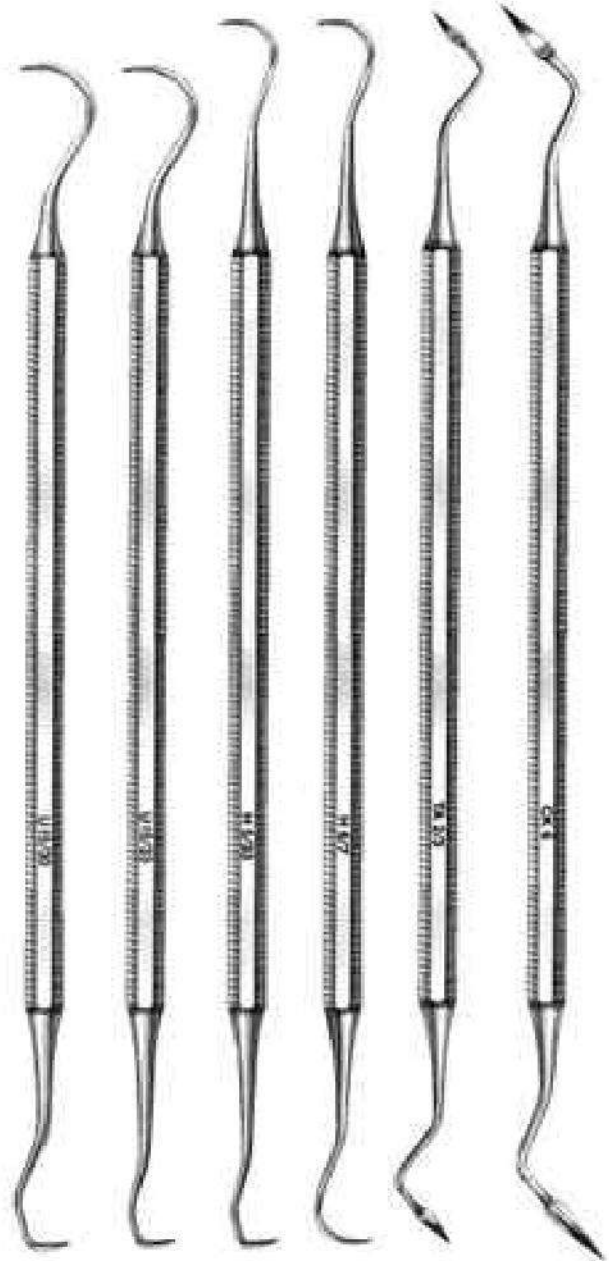

- 1551 U15-30
- 1552 U15-33
- 1553 H5-33
- 1554 H6-7
- 1555 Taylor 2-3
- 1556 Ck6



Scalers



1557
U15



1558
No.3

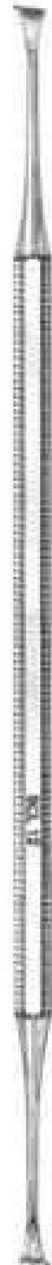

1559
No.12



1560
WHITESIDE 1-0

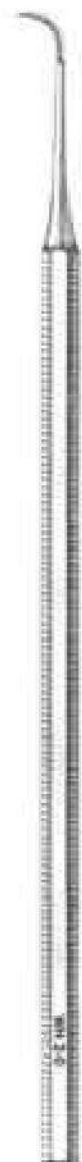

1561
WHITESIDE 2-0



Scalers



1562
YAOUNGER/GOOD
7-8



1563
H5-33



1564
204SD



1565
H6-7



1566
204S



1567
TOWNER/JAQUETTE
U15-30



Scalers



1568
JAQUETTE (33-U15)



1569
JAQUETTE
2Y-3Y



1570
JAQUETTE
30-U15



1571
JAQUETTE
2YS-3YS

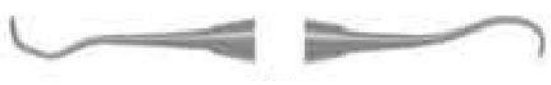

1572
JAQUETTE
33-H5



1573
YOUNGER/ GOOD
7-8



1574
204S



1575
204SD



1576
H6-7

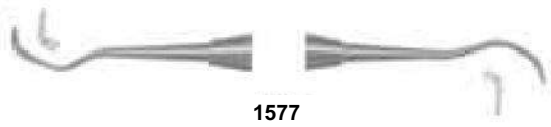

1577
JAQUETTE
2S-3S



1578
JAQUETTE
1Y-1YS

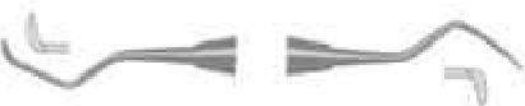

1579
JAQUETTE
2-3



Scalers



1580
JAQUETTE (33-U15)



1581
S204



1583
S204SD

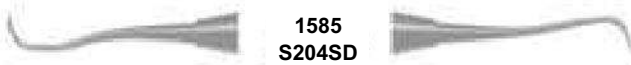

1585
S204SD



1587
Goldman 6-7

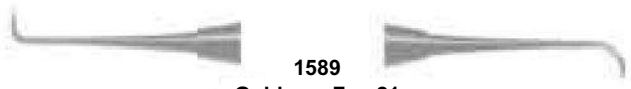

1589
Goldman Fox 21

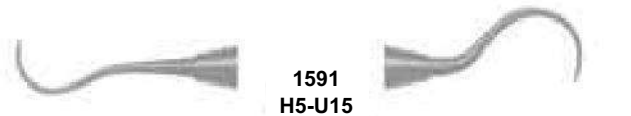

1591
H5-U15



1593
Jaquette 34-35



1595
Thompson Jr.

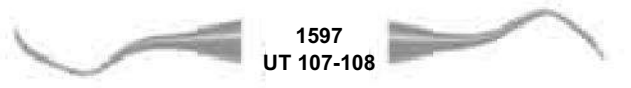

1597
UT 107-108



1599
Up128



1582
Jack-Nebraska



1584
Jaquette 1-U15



1586
Jaquette 2-3



1588
Jaquette 2S-3S

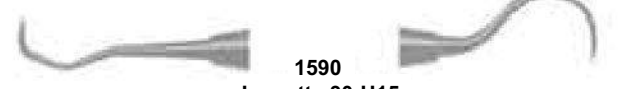

1590
Jaquette 30-U15



1592
Jaquette 30-33



1594
Jaquette 31-32



1596
Jaquette 33-H5

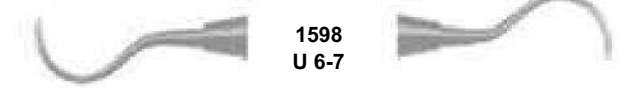

1598
U 6-7



1600
128L



Explorers

Explorers Double Ended-Octagonal

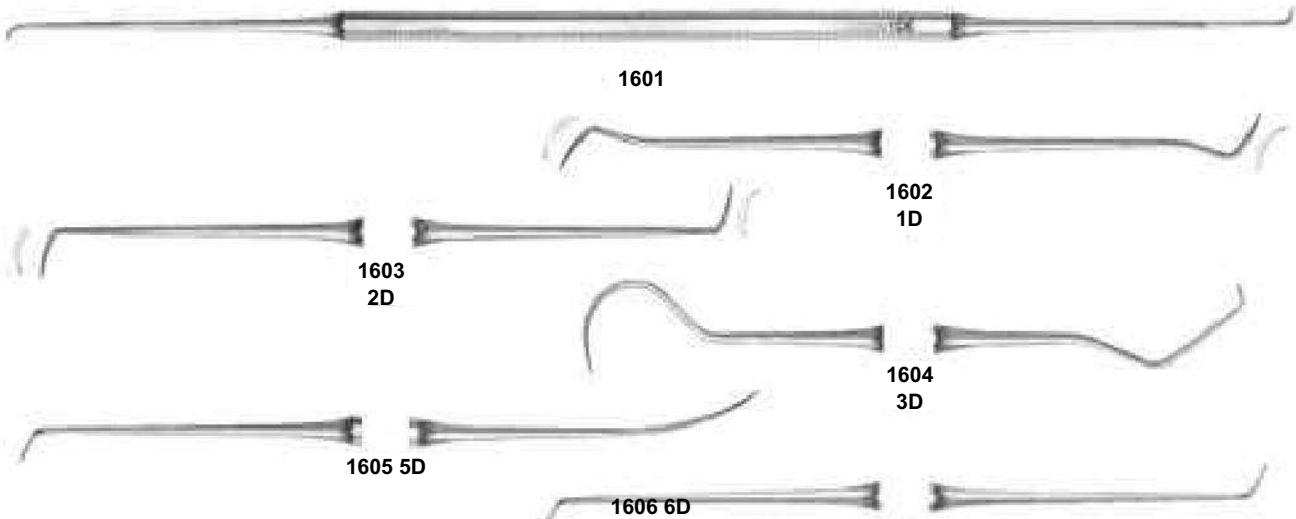

Explorers Double Ended-Standard

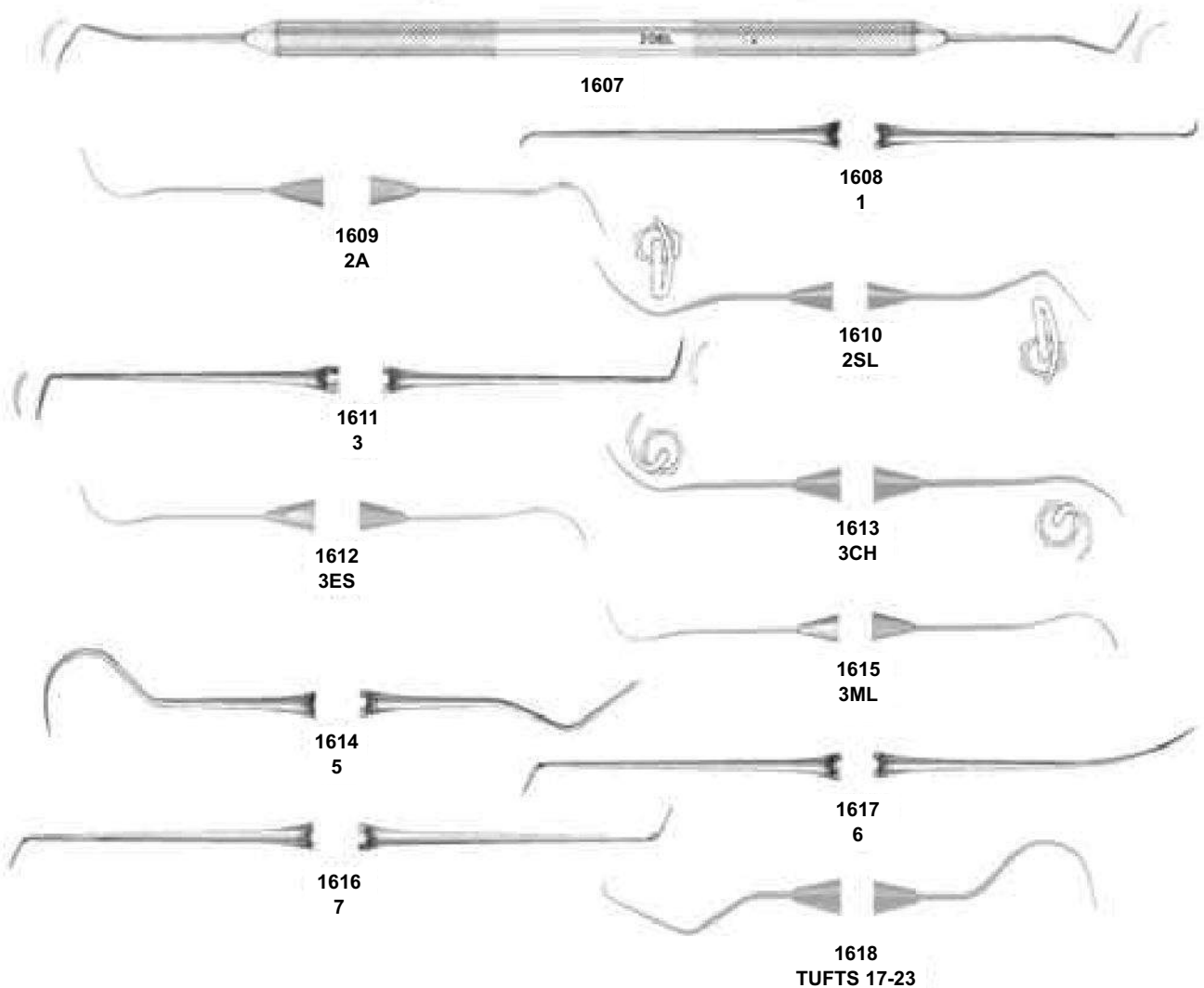



Explorers

Explorers Double Ended Tactile Tone



1619
2A

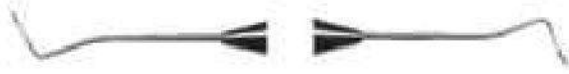

1620
2



1621
1



1622
2SL



1623
3



1624
3CH

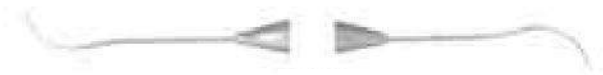

1625
3ES



1626
3ML



1627
5



1628
6



1629
7



1630
16



1631
TUFTS 17/23



Explorers & Probes

Explorers Single Ended - Octagonal



1632
Fig. 3A



1633
Fig. 17



1634
Fig. 7



1635
Fig. 17



1636
Fig. 17

Explorers Single Ended - Standard



1637
Fig. 3A



1638
Fig. 6



1639
Fig. 7



1640
Fig. 17



1641
Fig. 23

Probe / Explorer - Octagonal

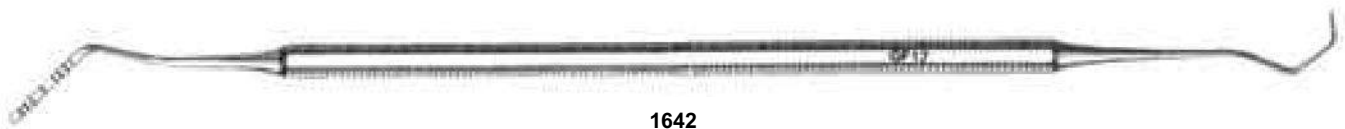

1642
Fig. 17

Double Ended Probe - Octagonal

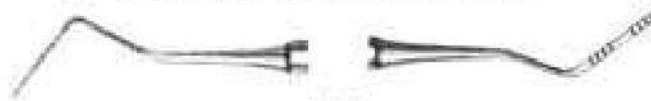

1643
Fig. 18(1-2)



Probes

Probes Double Ended-Standard

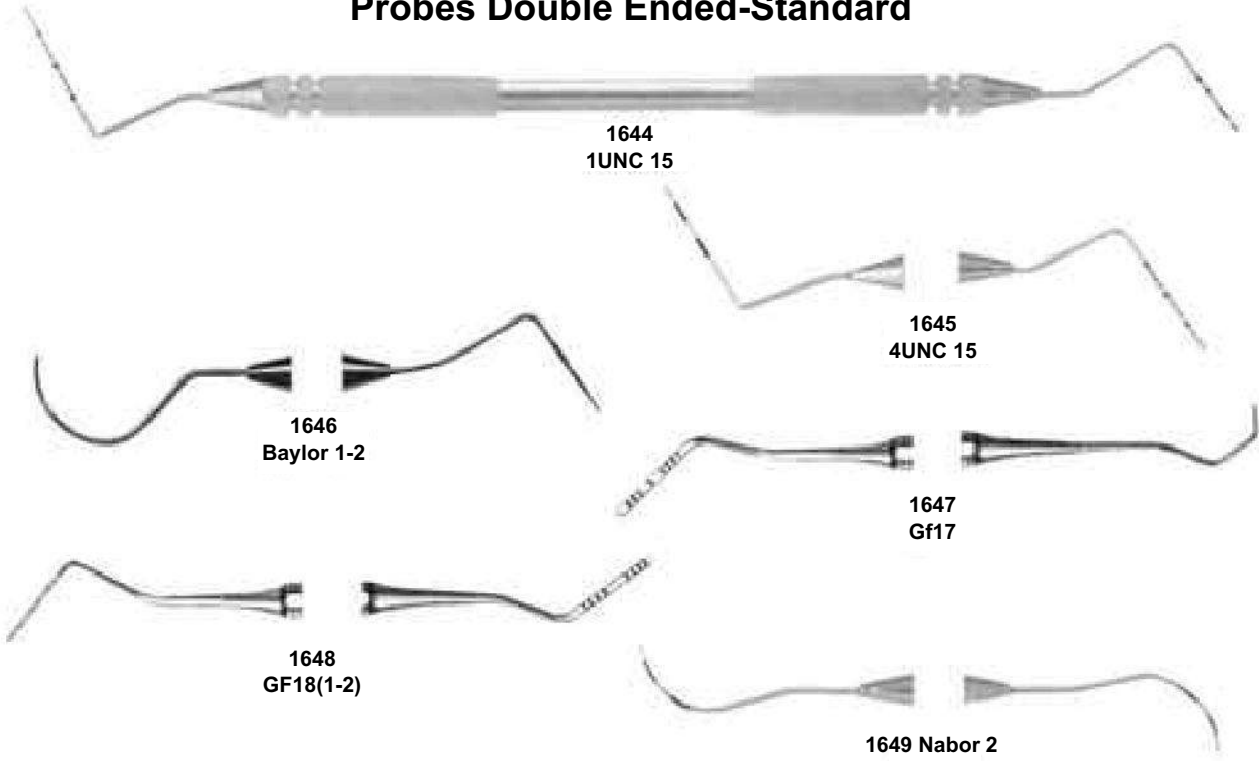

Probes Double Ended-Tactile Tone

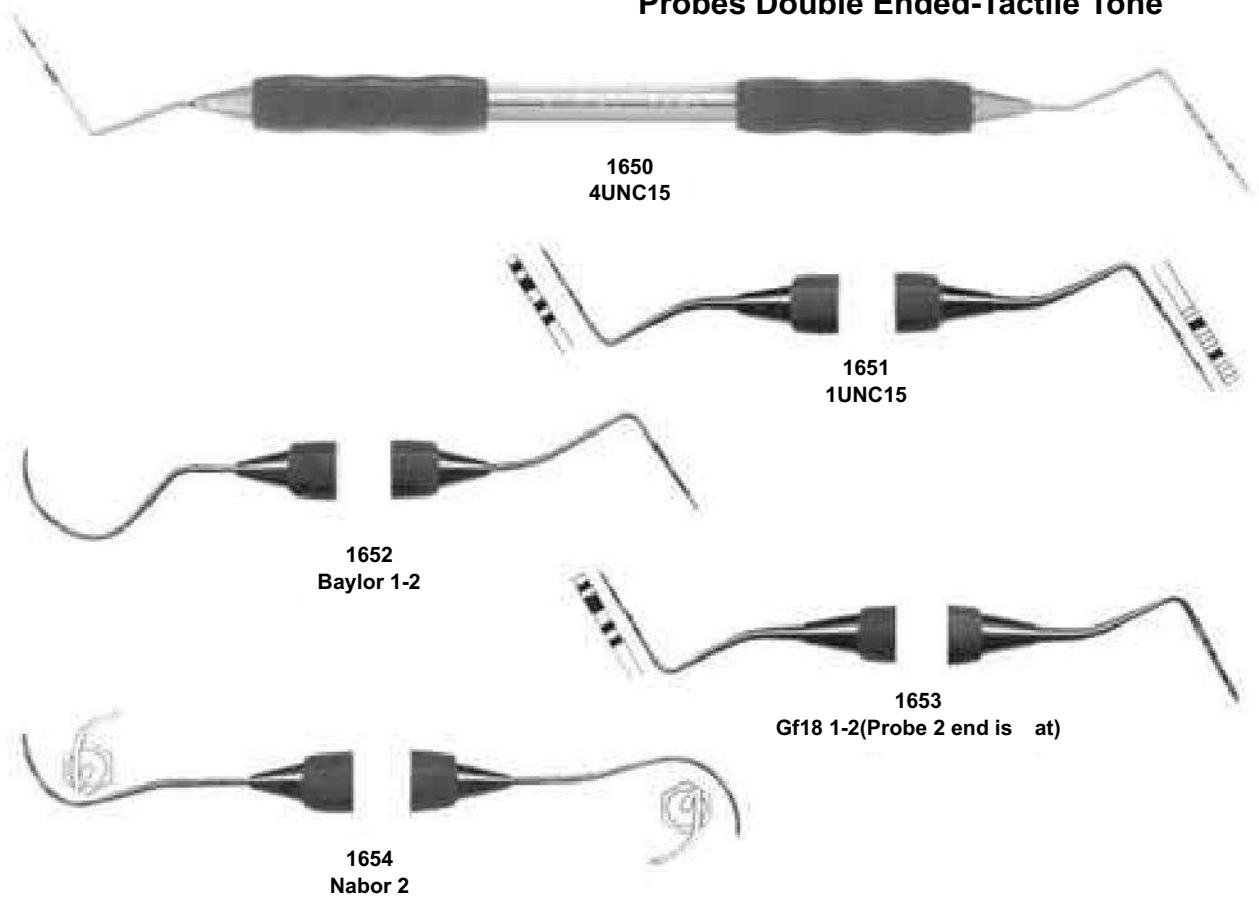



Probes

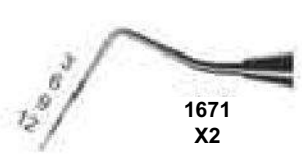
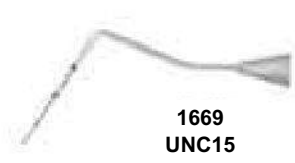
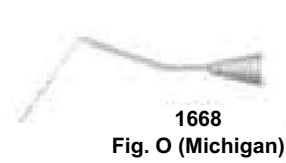
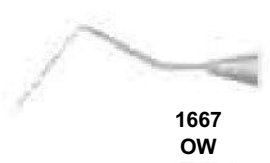
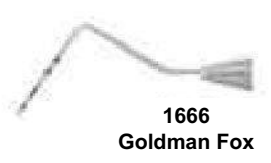
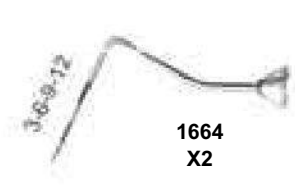
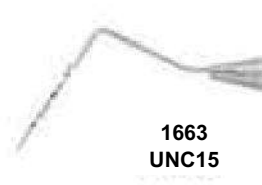
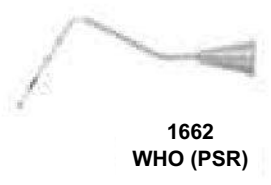
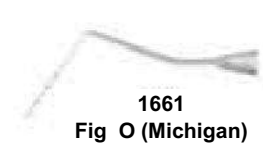
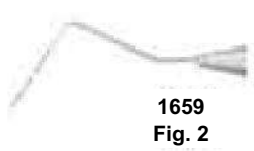
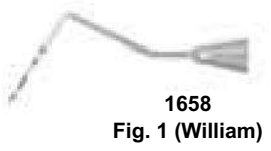
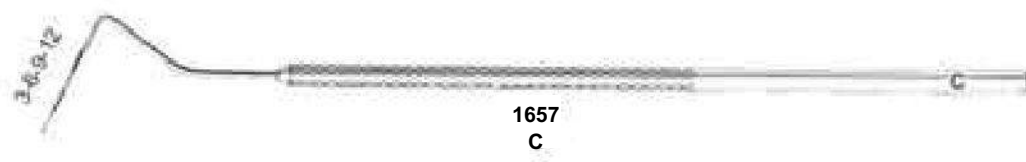
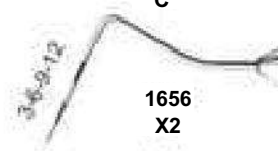
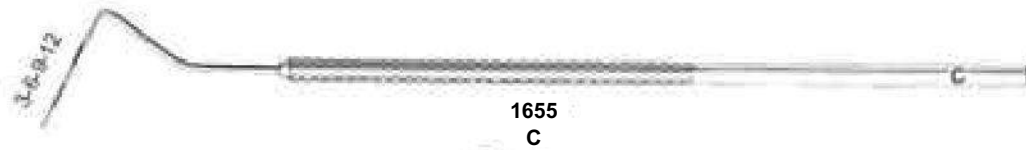



Probes

Probes Double Ended-Standard

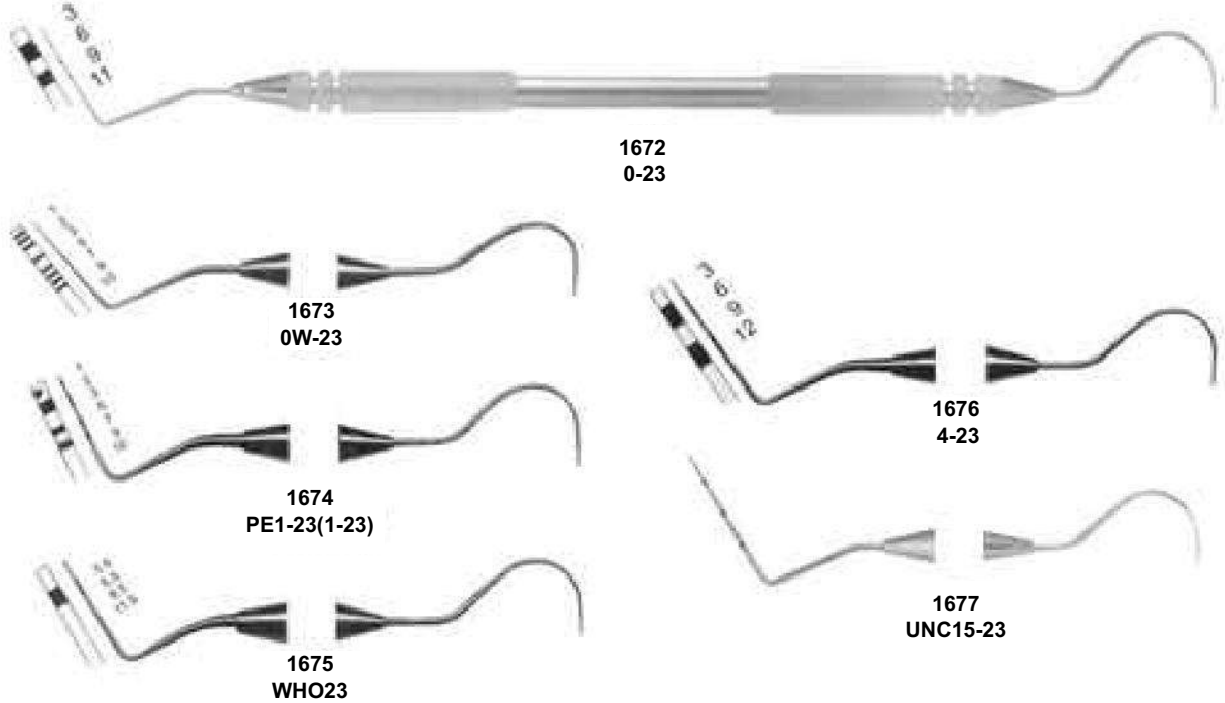

Probes Double Ended-Tactile Tone

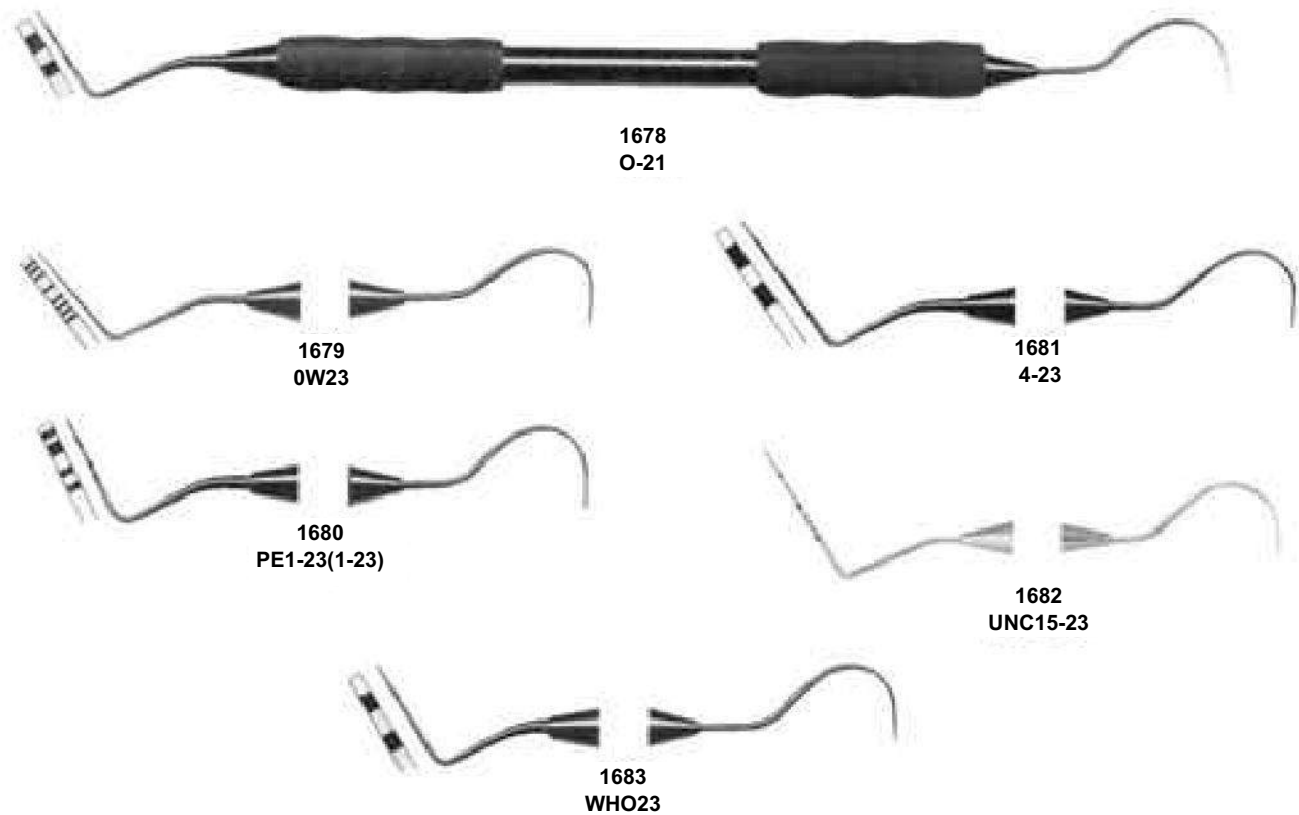



Endodontic Condensers

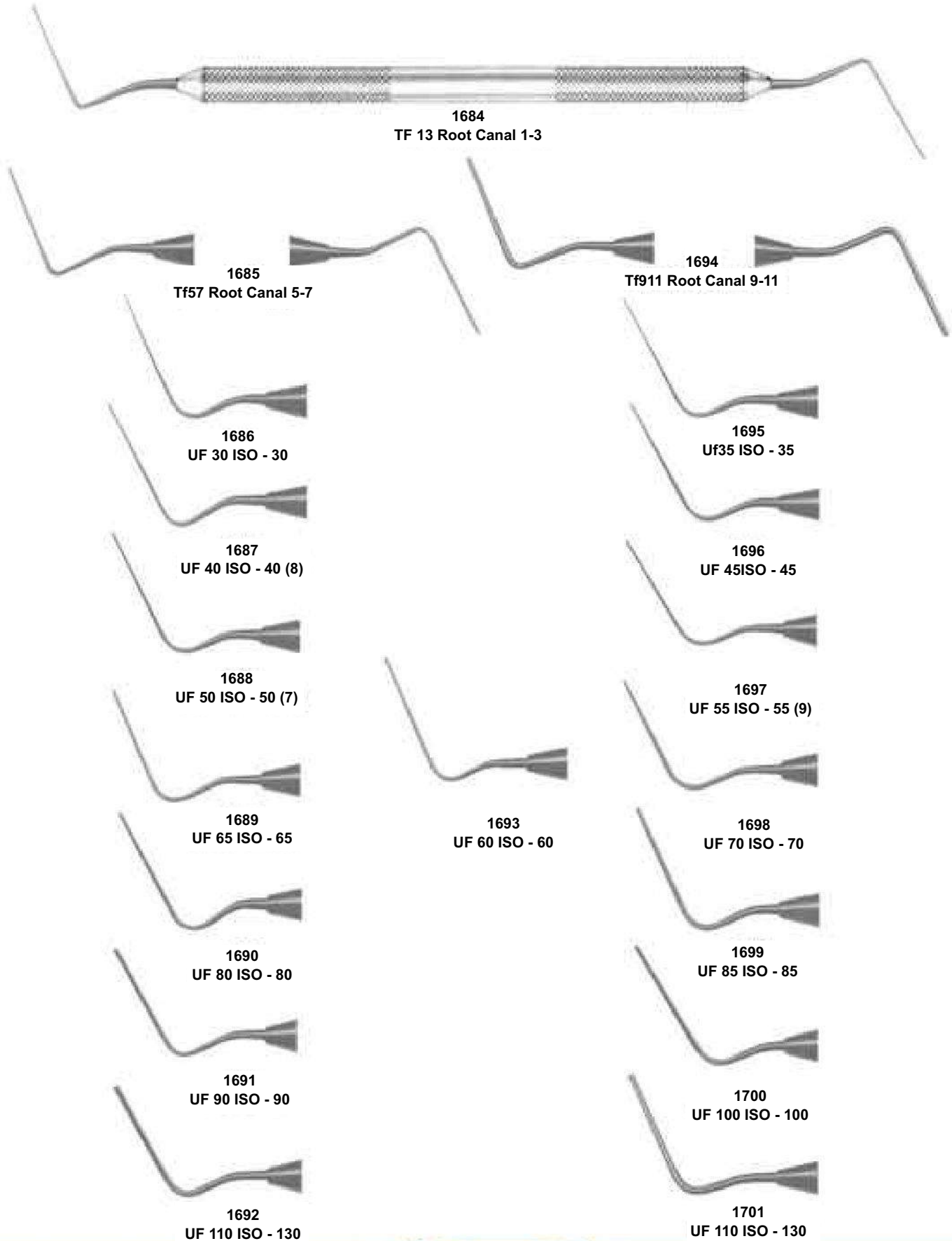



Endodontic Condensers/Spreaders



1702
UF 120X



1703
UF 45N



1704
UF 60N



1705
UF 80N



1706
UF 100X

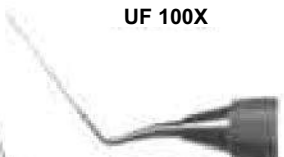

1707
UE 25 R-25



1708
UE 30 R-30



1709
UE 35 R-35



1710
UE 40 R-40



1711
UE 45 R-45



1712
UE 50 R-50



1713
UF 120X

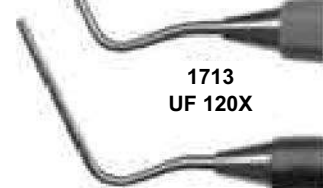

1714
UF 140X



1715
TFD 3545N



1716
TFD 6080N



1717
UE 55 R-55



1718
UE 60N R-60



1719
UE 25N R-25



1720
UE 30N R-30

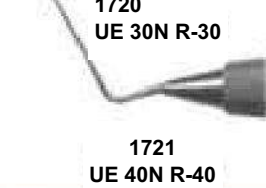

1721
UE 40N R-40



Obturation Instruments

1722
No. D11

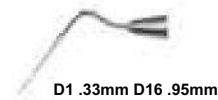

D1 .33mm D16 .95mm

1723
No. D11T



D1 .24mm D2 .84mm

1724
No. KR1

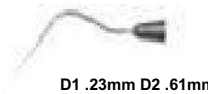

D1 .23mm D2 .61mm

1725
No. 25S

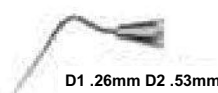

D1 .26mm D2 .53mm

1726
No. W1S

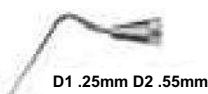

D1 .25mm D2 .55mm

1727
No. W2S

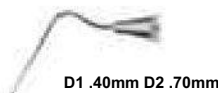

D1 .40mm D2 .70mm



1728
Lucks No. 1



1729
Lucks No. 2



1730
Lucks No. 3



1731
Lucks No. 4

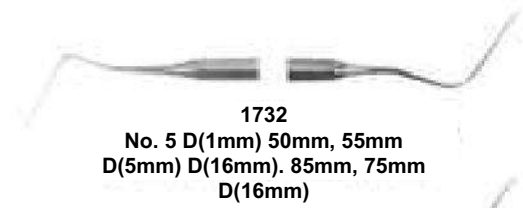

1732
No. 5 D(1mm) 50mm, 55mm
D(5mm) D(16mm). 85mm, 75mm
D(16mm)

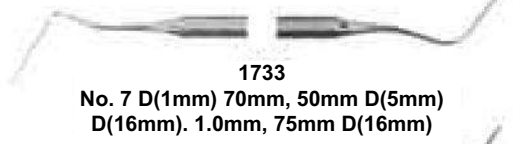

1733
No. 7 D(1mm) 70mm, 50mm D(5mm)
D(16mm). 1.0mm, 75mm D(16mm)

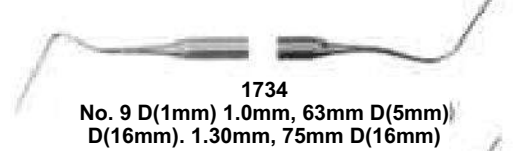

1734
No. 9 D(1mm) 1.0mm, 63mm D(5mm)
D(16mm). 1.30mm, 75mm D(16mm)

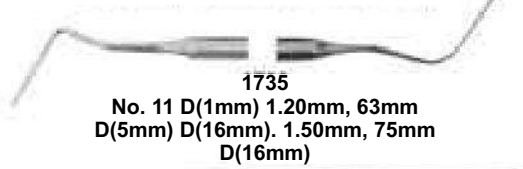

1735
No. 11 D(1mm) 1.20mm, 63mm
D(5mm) D(16mm). 1.50mm, 75mm
D(16mm)

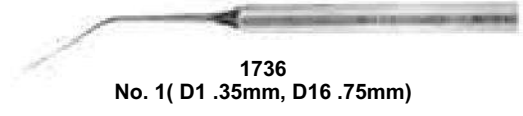

1736
No. 1(D1 .35mm, D16 .75mm)



1737
No. 2(D1 .55mm, D16 .85mm)

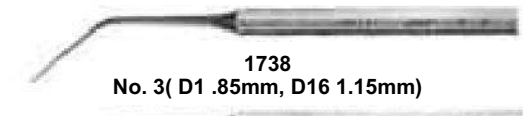

1738
No. 3(D1 .85mm, D16 1.15mm)

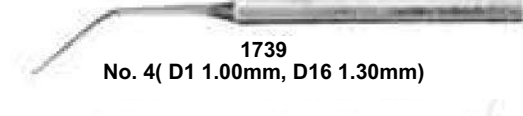

1739
No. 4(D1 1.00mm, D16 1.30mm)



1740
No. 1-3- D1 .25mm/D1 .35mm



1741
No. 3-5- D1 .35mm/D1 .55mm



1742
No. 5-7- D1 .55mm/D1 .70mm

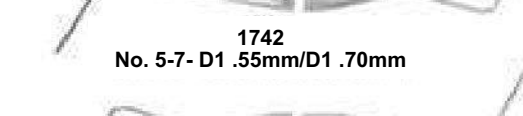

1743
No. 9-11- D1 1.00mm/D1 1.20mm



Excavators

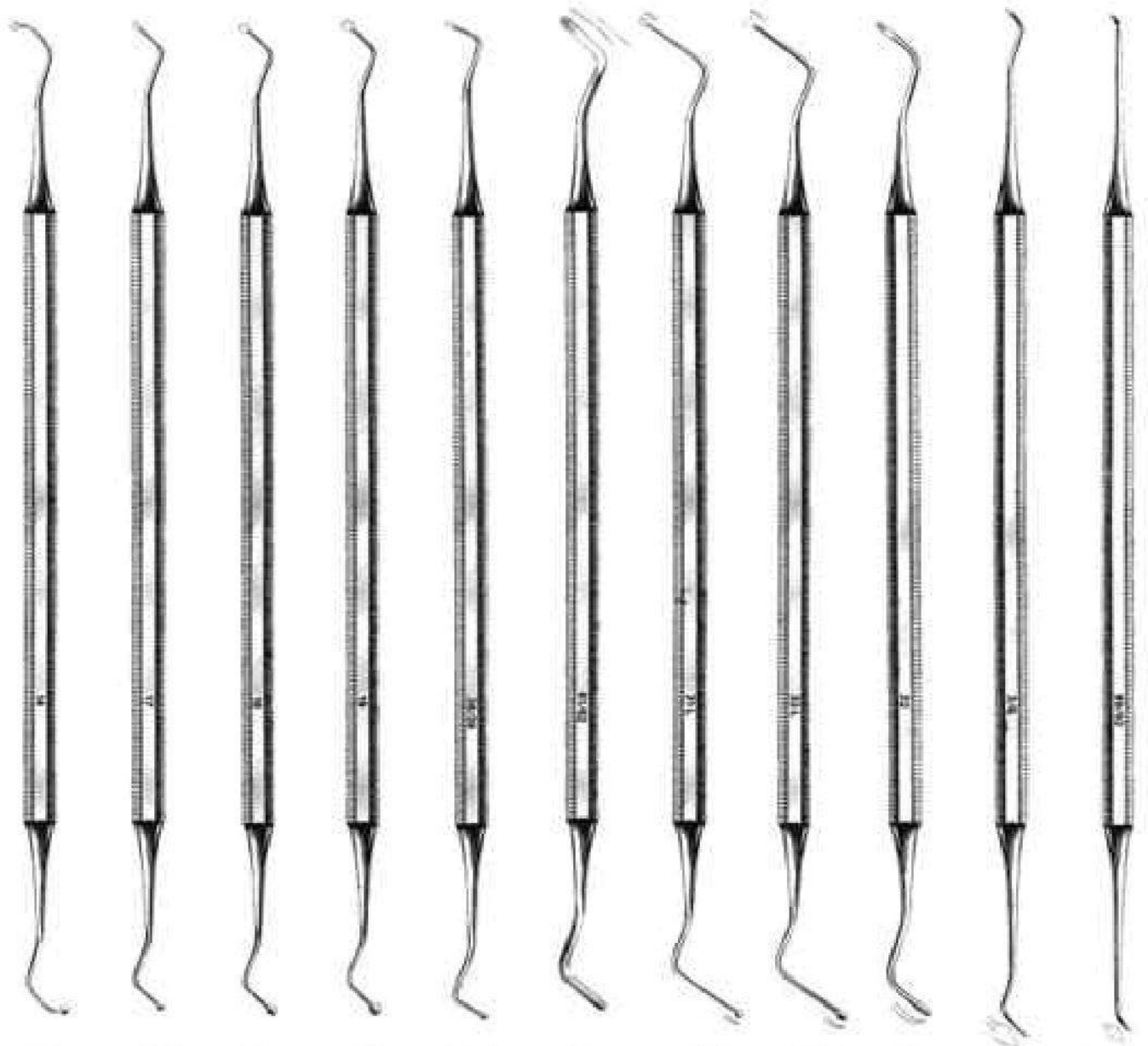

1744
No. 14

1745
No. 17

1746
No. 18

1747
No. 19

1748
No. 38/639

1749
No. 61/62

1750
No. 31L

1751
No. 33L

1752
No. 22

1753
No. 3/6

1754
No. 89/92



Excavators



1755
1mm Discoid(10-7-14)



1756
1mm Discoid(38-30)(11-5-7-14)



1757
E2 Discoid(15-8-15)



1758
1.5mm Discoid(15-8-14)



1759
E3 Discoid(25-9-15)



1760
2mm Discoid(20-9-14)



1761
1.5mm Spoon(15-8-14)



1762
E1 Discoid (12-9-15)



1763
2mm Spoon (20-9-14)



1764
17 Tear Drop



1765
19 Tear Drop



1766
18 Tear Drop



1767
20 Tear Drop





Excavators, Explorer/ Probes

Excavators

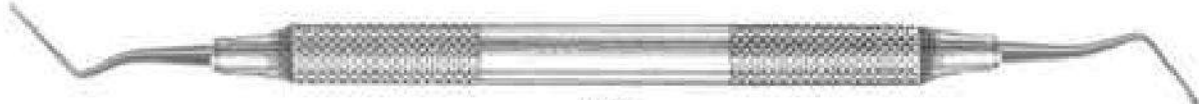

1768
31L



1769
31W



1770
33L



1771
32L



1773
Explorer No.2



1774
Explorer No.16

Explorers / Probes



1772
G16D-L

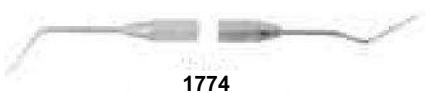

1775
16-23 Explorer



1776
16-17 Explorer



1777
DG 16 Explorer



1778
Heavy DG 16





Explorers





Explorers

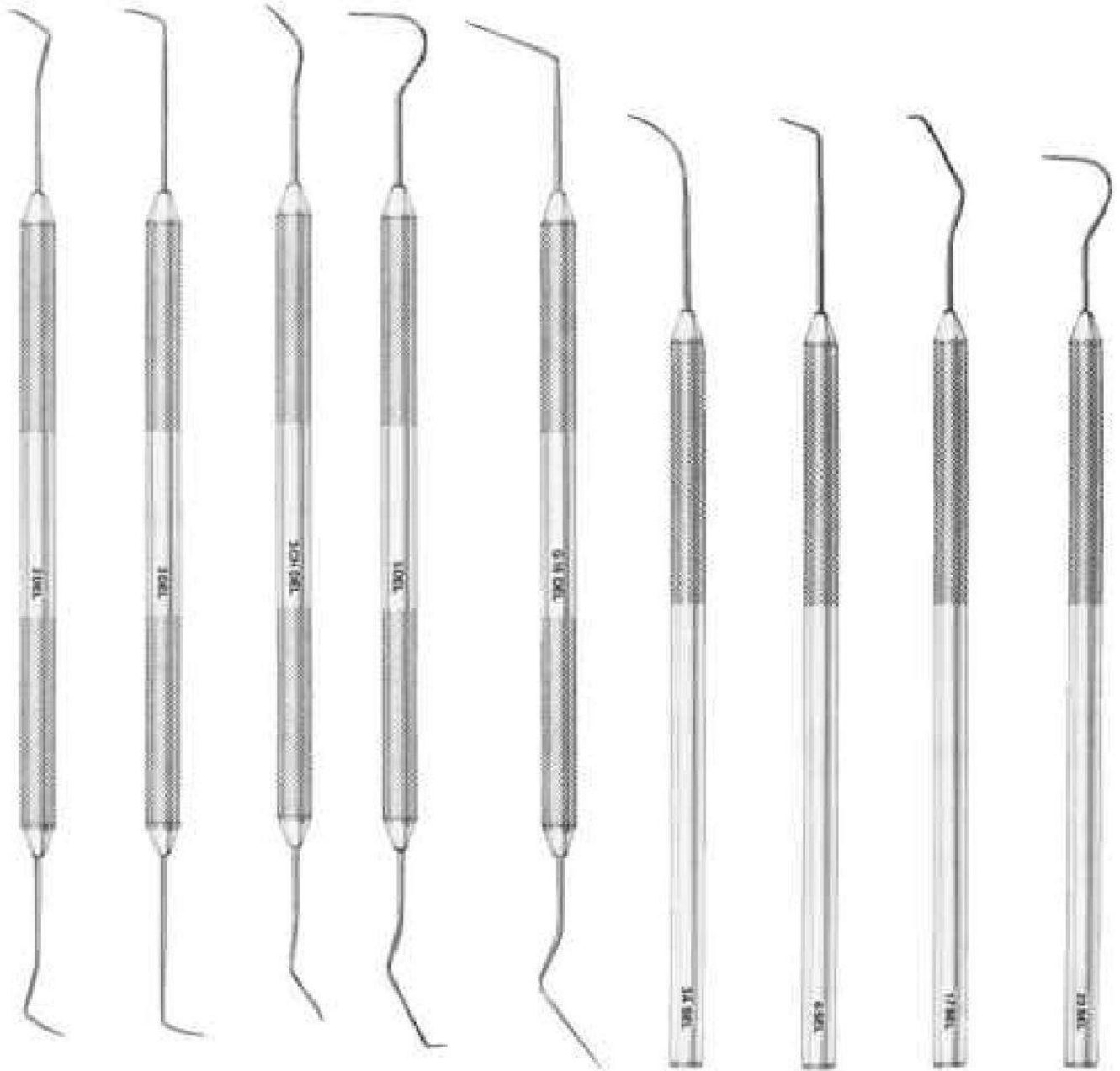

1790
No 2D-L

1791
No 3D-L

1792
No 3CHD-L

1793
No 5D-L

1794
No G16D-L

1795
No 3AS-L

1796
No 6S-L

1797
No 17S-L

1798
No 23S-L



Explorer / Probe Combination



1799
Gf17 Probe/ Explorer

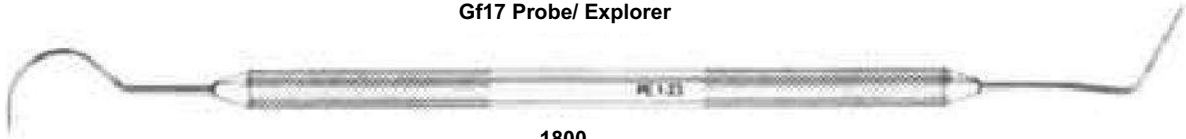

1800
PE 1-23 Probe/ Explorer



1801
PE 0-23 Explorer(Fine)



1802
PROBE 1/23 Explorer

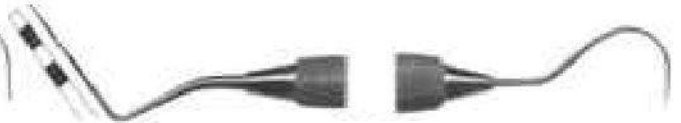

1804
PROBE 4/23 Explorer



1803
Probe OW/ 23 Explorer



1805
Ball Tip Probe WHO/ 23 Explorer

PROBES

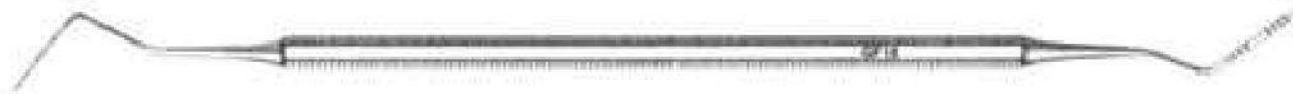

1806
Gf18 Probe

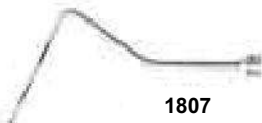

1807
"C" Probe



1808
"X2" Probe

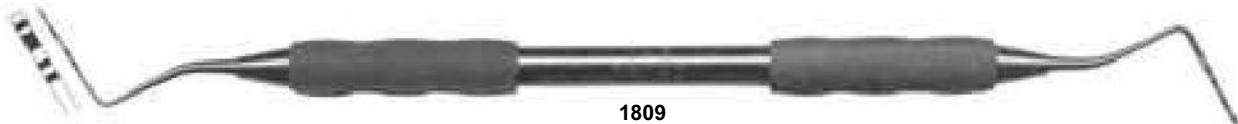

1809
1-2 (Probe 2 end is at)

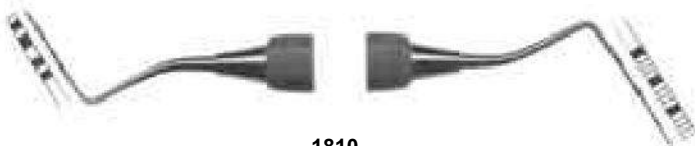

1810
1 UNC 15



1811
4 SE



Cord Packers, Hatchets, Hoes

CORD PACKERS



1812

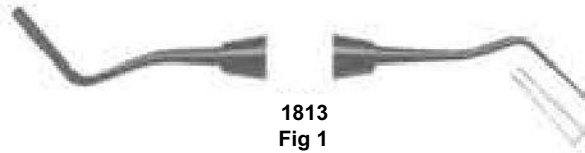

1813
Fig 1



1814
Fig 2



1815
BLOOMFIELD
Fig. 2(off angle)



1816
Fig. 1



1817
CSI-1(slightly serrated on ends)

HATCHETS



1818
1mm(10-7-14)



1819
1.3mm(13-10-16)



1820
1.5mm(18-8-14)

HOES



1821
1mm(10-8-16)



1822
UWH 18-19



1823
UWH 16-18



1824
UWH 20-21



PK.Thomas Waxing & Gracey Curetts Set



1825
PK.Thomas 1



1826
PK.Thomas 2



1827
PK.Thomas 3



1828
PK.Thomas 4



1829
PK.Thomas 5

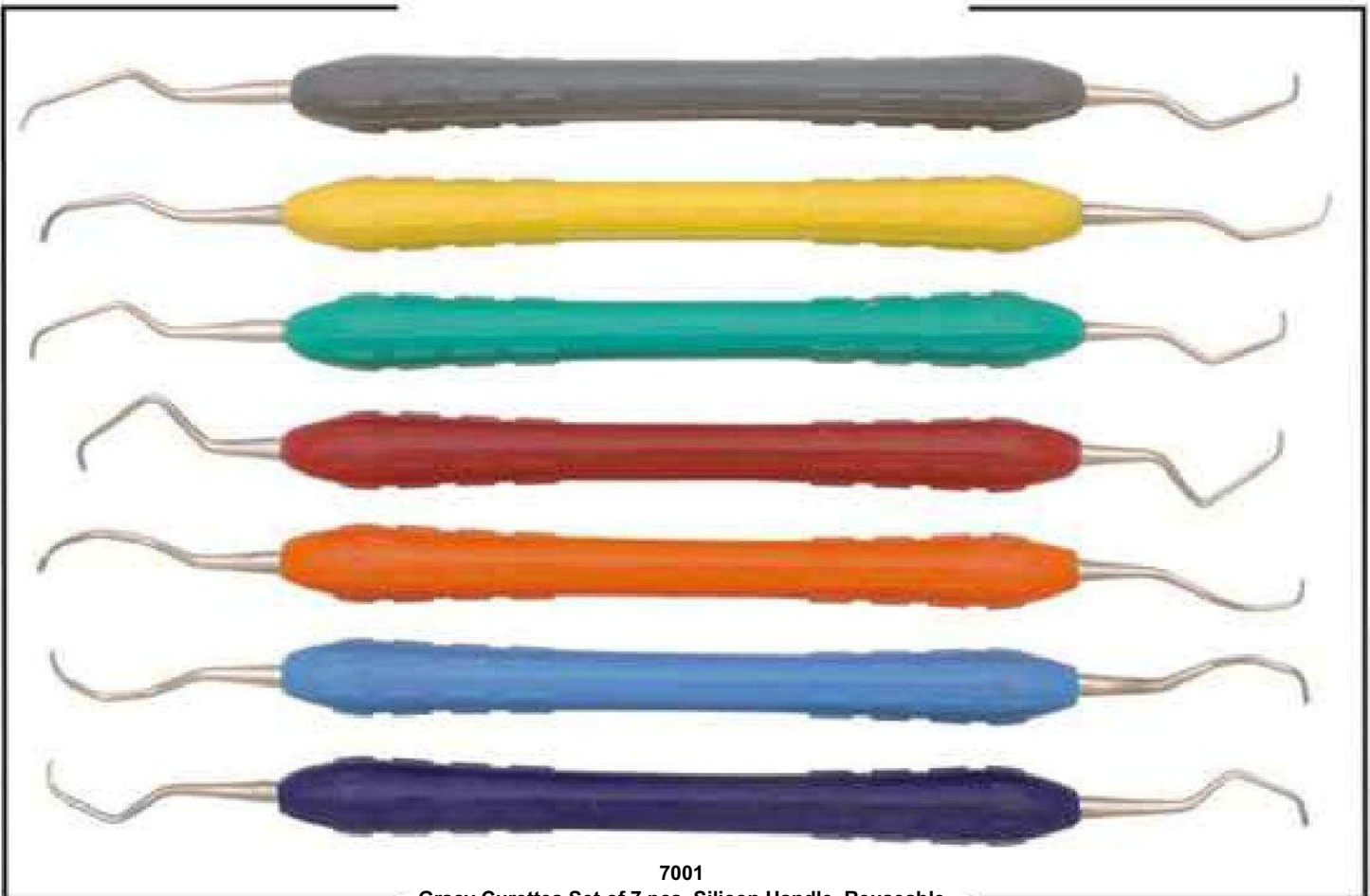

7001
Gracy Curettes Set of 7 pcs, Silicon Handle, Reuseable



**Amalgam Pluggers/ Condensers/
Applicators**



1830
BEHRMAN (Fig. 1)



1831
BLACK (Fig. 1-2)



1832
MORQUETTE (Fig. 0/1)



1834
Hollenback No.1 Plugger



1835
Hollenback No.2 Plugger



1833
Black Action 11/12 Plugger



1836
Hollenback No.3 Plugger



1837
Blacks0.1 (1mm-1.5mm)



1838
Blacks1.5 (1.5mm-2.5mm)



1839
Bodkin 1 (.7mm-1mm)



1843
7mm-1mm



1844
1mm-1.5mm



1840
Bodkin 2 (1.5mm-2mm)



1845
1.5mm-2mm



1841
2.5mm 3mm



1846
Oregon (Fig. 3)



1842
Oregon 2



1847
Oregon (Fig. 4)



1848
UP 12



1849
Applicator 1-2



1850
Birtles Applicator Spatula

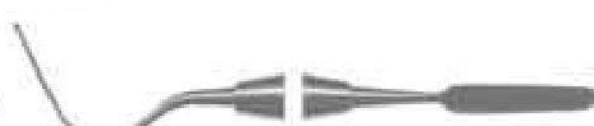

1851
Birtles Applicator Spatula K20-21



**Placement Instruments,
Stopping Stoppers, Plugg**

Placement Instruments



1852
PICH (Calcium Hydroxide Placer)

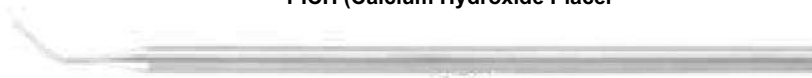

1853
CA

Stopping Stoppers



1854
Woodson 2

Ø 1.6 mm



1855
Woodson 3S

Ø 2.4 mm

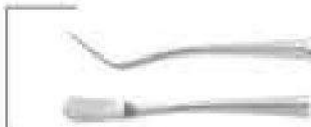

1856
Woodson 3A

Ø 2.6 mm



1857
Woodson 3

Ø 3.0 mm

Pluggers



Ø 0.75 mm

1858
Plugger 0-1

Ø 1.2 mm



Ø 1.2 mm

1859
Plugger 1-4

Ø 1.6 mm



Ø 1.6 mm

1860
Plugger 4-6

Ø 2.0 mm



Ø 2.0 mm

1861
Plugger 6-8

Ø 2.5 mm



Ø 1.5 mm

1862
Black 1-2

Ø 2.6 mm



Ø 3.6 mm

1863
Black 2-3

Ø 5.0 mm

Section - 03

- Burnishers • Carvers • Chisels
- Composite Placements
- Filling Instruments • Curettes
- Disposable Instruments





Burnishers

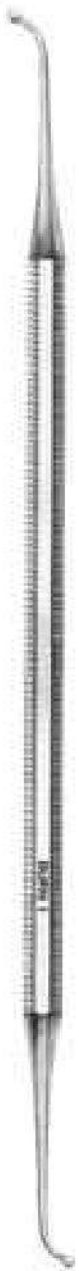

1864
Fig. 1



1865
Fig. 28/29

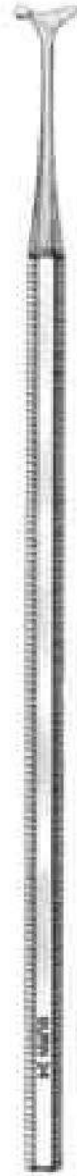

1866
Fig. 34



1867
Fig. 27/29



1868
Fig. 21B

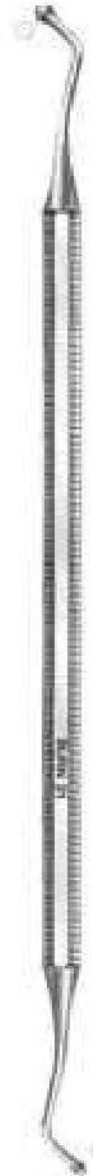

1869
ACOR
N
Fig.21



Burnishers



1870
21 Acom



1871
Fig. 21B



1872
Fig. 2-34



1873
Fig. 21C



1874
Fig. 26-28



1875
Fig. 2-30



1876
Fig. 25-30



1877
Fig. 27-29



1878
PKT1



1879
Fig. 27-30



1880
PKT2



1881
Fig 34T



1882
Fig 3



1883
PKT3



1884
PFI21



1885
PKT 3P

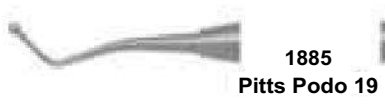

1885
Pitts Podo 19



1887
PKT 4

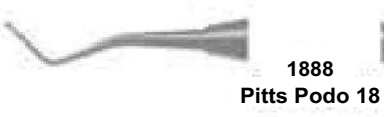

1888
Pitts Podo 18



1889
PKT 5

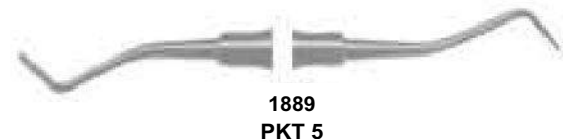



Wax Carvers



1890
HOLLENBACK
Fig. 3



1891
HOLLENBACK
Fig. 3S

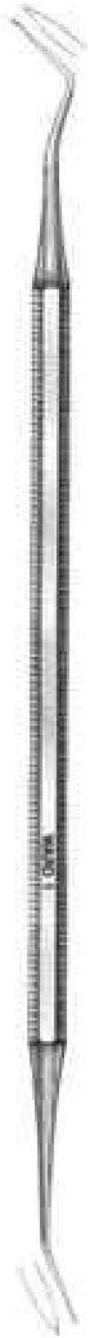

1892
WARD
D Fig. 1



1893
WARD
D Fig. 2

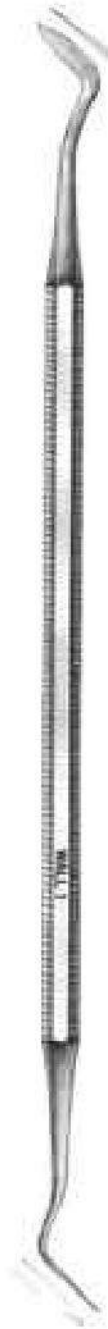

1894
WALL
Fig. 1



1895
WALL
Fig. 3



1886
Fig. 3/6
Cleoid/Discoid



1897
Fig. 89/92
Cleoid/Discoid



Carvers



1898
1.5mm Cleoid Discoid (Shown with GTX Finish)



1899
2mm Cleoid Discoid



1901
3mm Cleoid Discoid



1900
GOLLOBIN
Fig. 1



1902
HOLLENBAC
K Fig. 1/2



1903
FRAHM
Fig. 2-3 (off-angle)



1904
HOLLENBAC
K Fig. 3



1905
Interproximal 1



1906
THOMPSON (Fig. 3)
1/2 Hollenback Hoe & Wall 3



1907
Interproximal 1



1908
THOMPSON (Fig. 5)
1/2 Hollenback Hoe & Tanner 5



1909
Baum Interproximal



1910
THOMPSON (Fig. 8)
3mm Cleoid & Wall 3



1911
SHO A Carver



1912
THOMPSON (Fig. 9)
Hollenback 3 & Wall 3



1913
Thompson 2



1914
WAR
D Fig.
2





Carvers, Chisels



1915
Composite Interproximal



1916
TANNE
R Fig. 5



1917
TANNE
R Fig. 0



1918
THARP
Fig. 1



1919
THOMPSON
Fig. 1



1920
University of Minnesota
Fig. 1



1921
University of Minnesota
Fig. 2



1922
UPR
Fig. 1



1923
WALL
Fig. 3

Contour Carbide Carvers - Finishing



1924
COUNTER CARBIDE Fig 1-2



1925
Cleoid Carbide



1926
Cleoid Carbide (Fig 10-11)

Chisels



1927
1.5mm Bin Angle (15-8-8)



1928
1.5mm Straight (15)



1930
1.5mm Wedelstaedt(15-15-3)



1929
1mm Wedelstaedt(10-15-3)

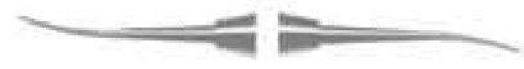

1931
2mm Wedelstaedt(20-15-3)



Composite Placement

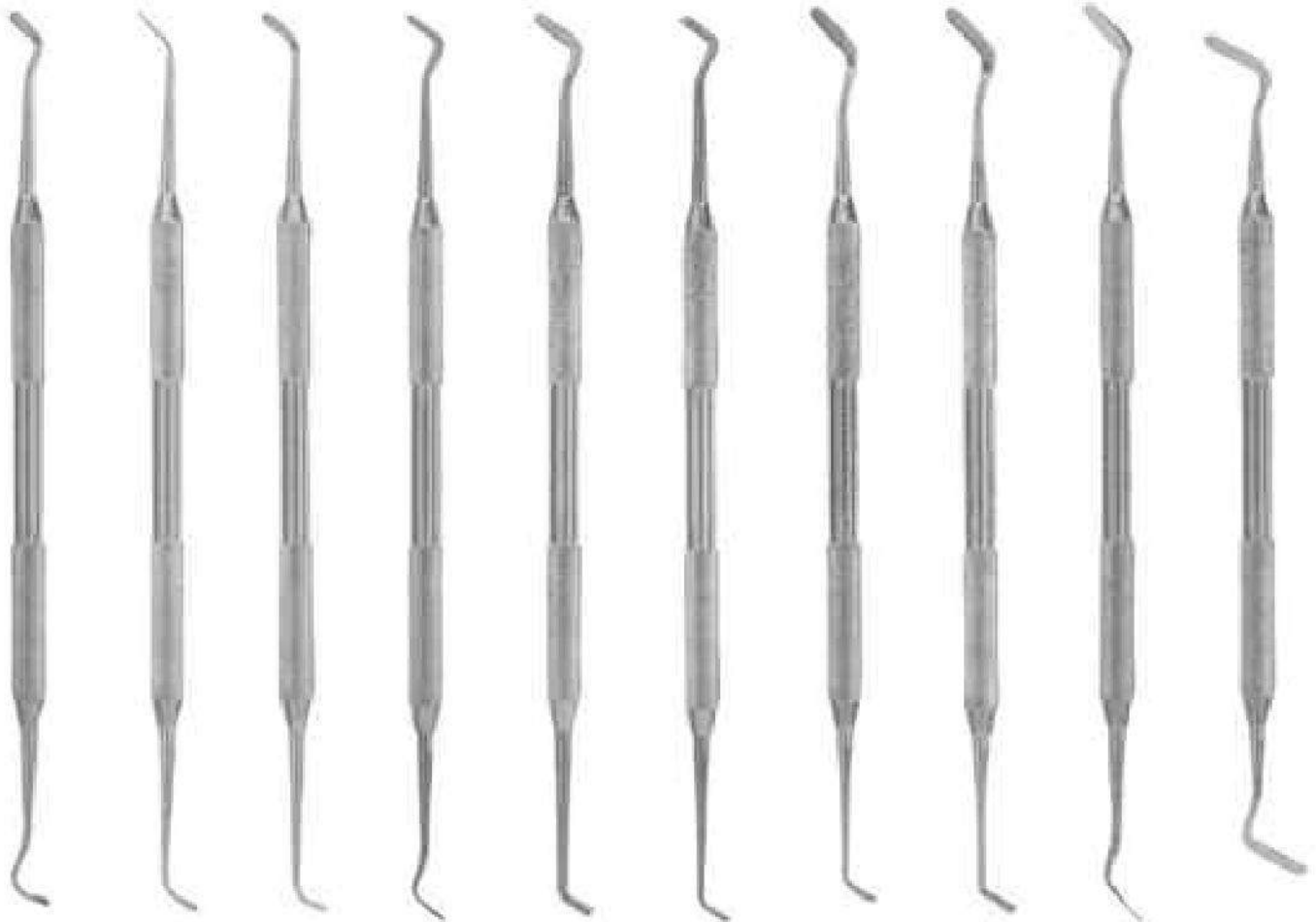

1932
F-Type 1

1933
F-Type 2

1934
F-Type 3

1935
F-Type 4

1936
F-Type 5

1937
F-Type 6

1938
G-Type 1

1939
G-Type 2

1940
G-Type 3

1941
G-Type 4

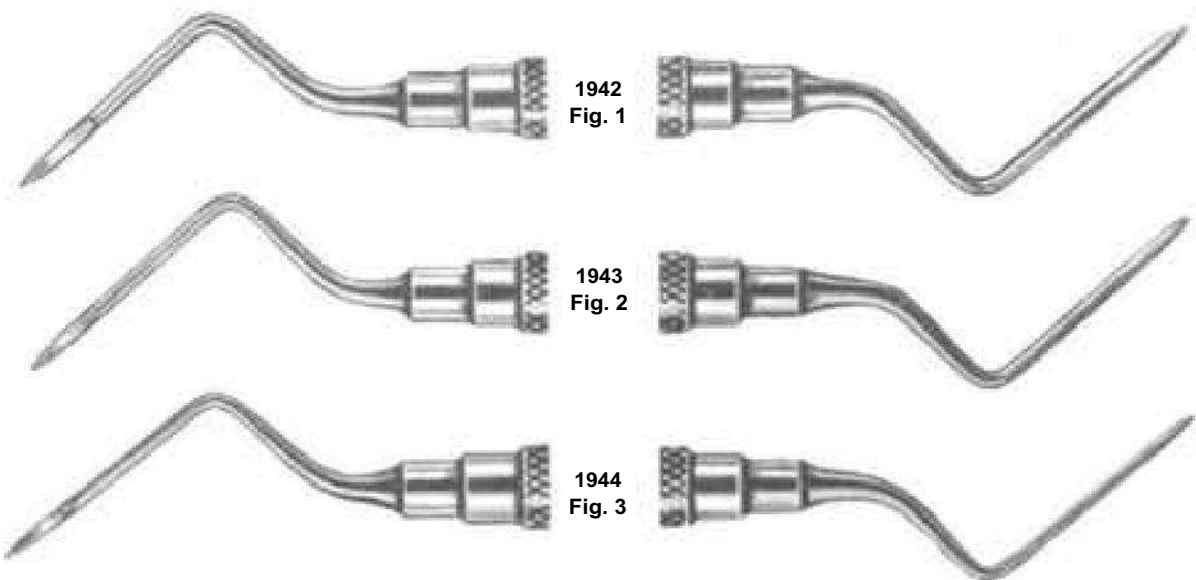

1942
Fig. 1

1943
Fig. 2

1944
Fig. 3



Composite Placement



1945
Fig. 2



1946
Fig. 3 (off-set blade)



1947
Fig. 4



1948
Fig. 5



1954
Fig. 12



1949
Fig. 6



1950
Fig. 7



1951
Fig. 8



1955
Fig. 15



1952
Fig. 9



1953
Fig. 11



1956
JORDAN
Fig. 2



1957
FREEDMAN
Fig. 1



1959
FREEDMAN
Fig. 2



1959
FREEDMAN
Fig. 3



1960
Dr. Dan



1961
SIMON
Fig. 2



K - Type

1962
K-Type 1



1963
K-Type 2



1964
K-Type 3



1965
K-Type 4



1966
K-Type 5



1967
K-Type 6 Carbide



Plastic Filling Instruments



1968
No.3

1969
No.4

1970
No.5

1971
LADMORE
Fig.3

1972
WOODSON
Fig.1

1973
WOODSON
Fig.2

1974
WOODSON
Fig.3

1975
W-3

1976
Gregg
4/5



Plastic Filling Instruments



1977
Fig. 5-7



1978
Fig. 1



1979
Fig. 3



1983
GUC
K Fig.
1



1980
Fig. 4



1984
P8



1981
Fig. 5-7



1985
WOODSON
Fig.1



1982
Fig. 8A



1986
WOODSON
Fig.2



1987
WOODSON
Fig.3





Curettes



1888
GRACY
GC 1-2



1889
GRACY
GC 3-4



1890
GRACY
GC 5-6



1891
GRACY
GC 7-8



1892
GRACY
GC 9-
10



1893
GRACY
GC 11-
12



1894
GRACY
GC 13-
14



Gracy Curettes

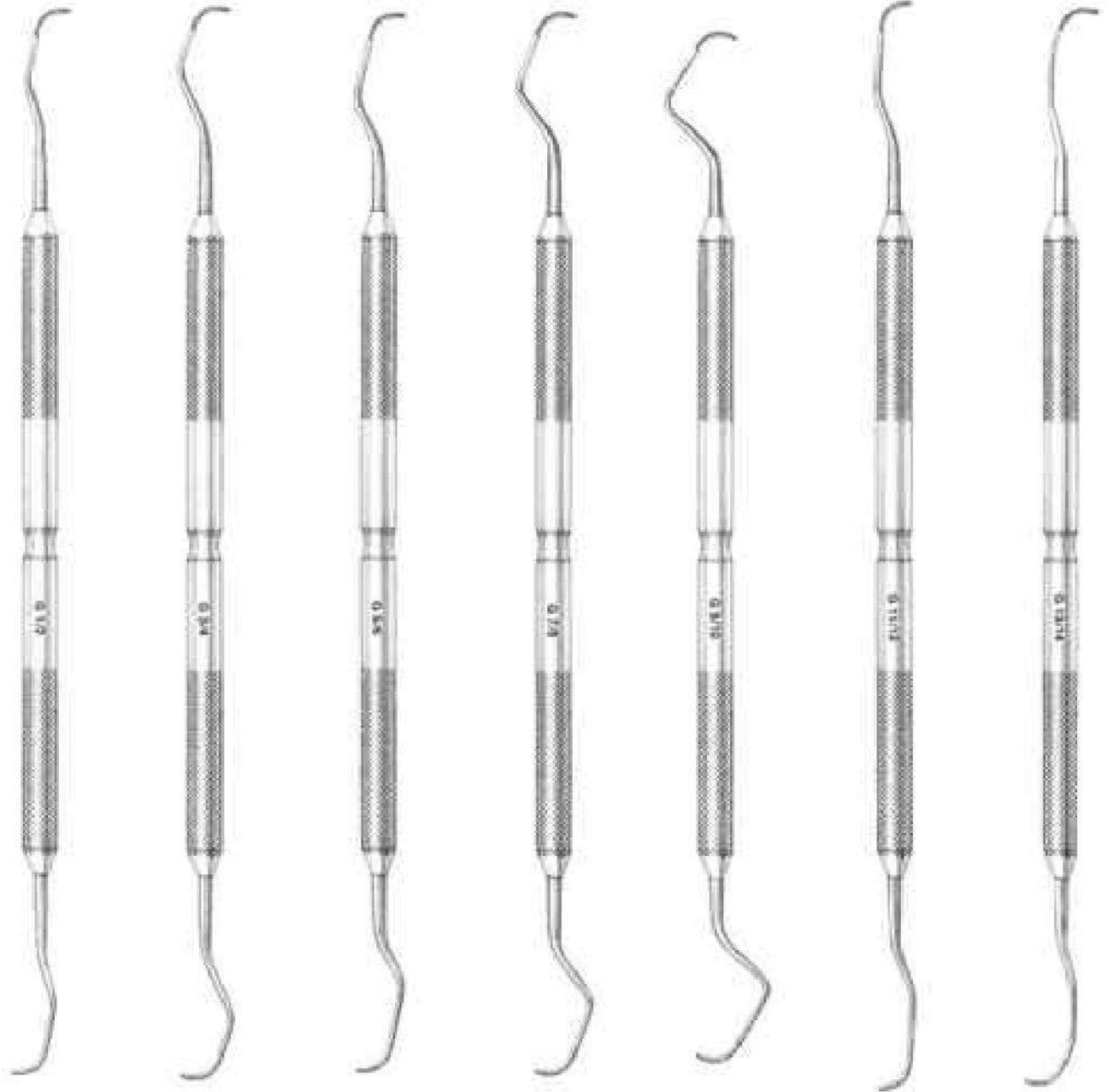

1995
G1-2

1996
G3-4

1997
G5-8

1998
G7-8

1999
G9-10

2000
G11-12

2001
G13-14



Curettes # 4. Handle

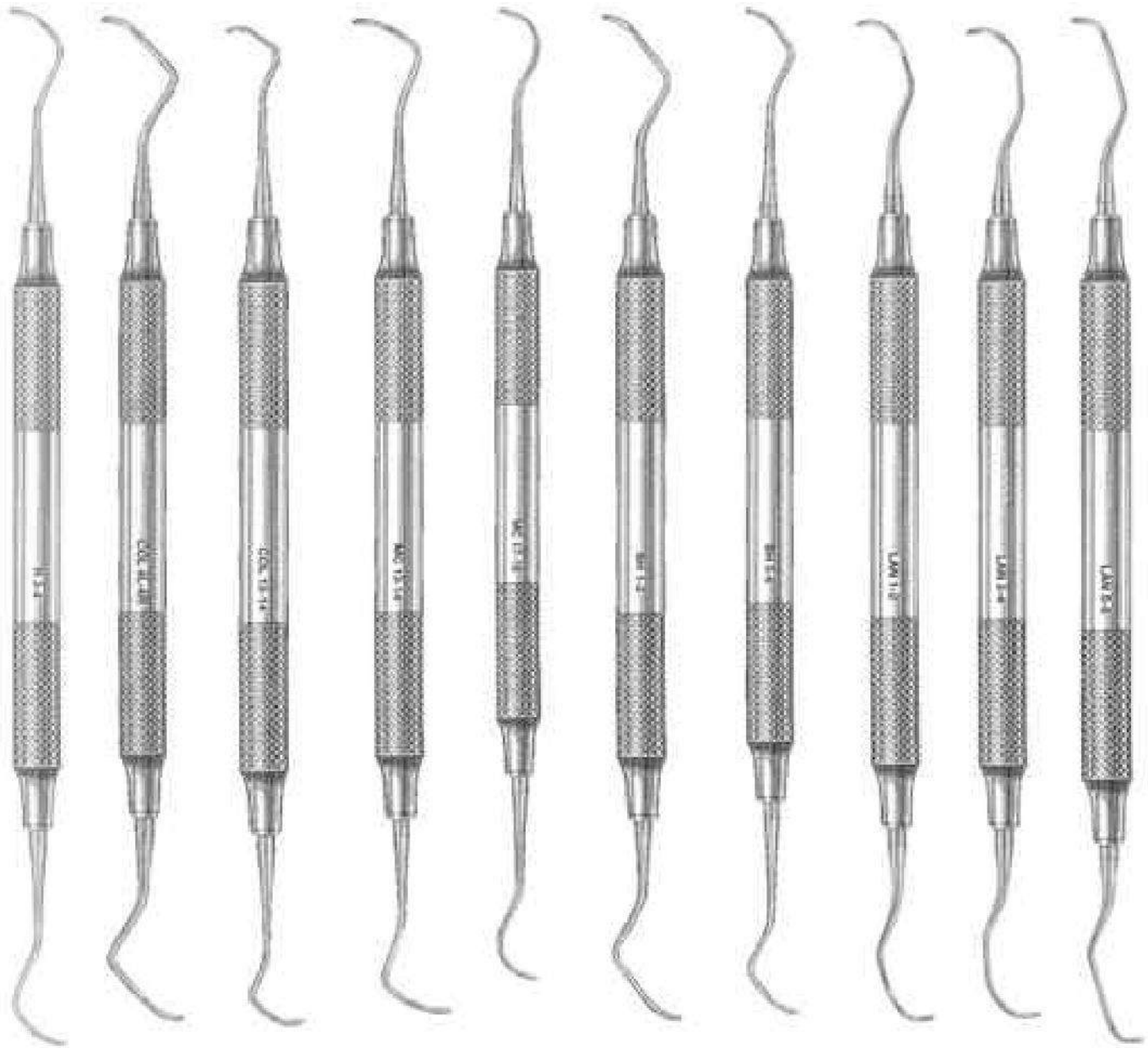

2002
RUL
E 3-4

2003
COLUMBIA
4\$-4L

2004
COLUMBIA
13-14

2005
MCCALL
S 13-14

2006
MCCALL
S 17-18

2007
BARNHAR
T 1-2

2008
BARNHAR
T 5-6

2009
LANGE
R 1-2

2010
LANGER
1-2

2011
LANGER
5-6



Curettes

COLUMBIA CURETTES



2012
4L-4R

2013
13-14

2014
2L-2R

MCCALLS CURETTES



2015
13-14

2016
13S-14S

2017
17-18

2018
17S-18S



Curettes

GOLDMAN FOX



2019
GF 1 Universal Scaler



2020
GF 2 Curette



2021
GF 3 Curette



2022
GF 4 Curette



2023
GF 5 HOE



2024
GF 6 HOE



Curettes

GOLDMAN FOX



2025
GF 7 Knife



2026
GF 8 Super Knife



2027
GF 9 Knife Scaler



2028
GF 11 Super Knife



2029
GF 21 Sharp Spoon/
Small Scaler



Knives, Interproximal Files



2030
GF 6 Krikland 15/16



2031
Ordan 1/2



2032
Buck 3/4



2033
Buck 5/8



2034
Goldman Fox 7



2035
Goldman Fox 8



2036
Goldman Fox 9



2037
Goldman Fox 11



2038
CK 3(Crane)

Interproximal Files



2039
Sugarman 1S-2S



2040
Sugarman 3S-4S



2041
Sugarman 9-10



2042
Buck 11-12



Curettes, Root Planning Curettes



2043
COLUMBIA (2L-2R)



2044
MCCALL (13-14)



2045
MCCALL (17S-18S)

Root Planning Curettes



2046
Root Plane (1-2)

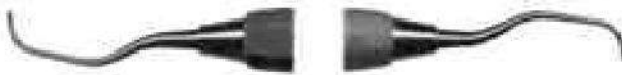

2047
Root Plane (5-6)



2049
Root Plane (11-12)

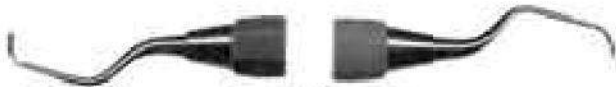

2048
Root Plane (17-18)



2050
Root Plane (13-14)



2051
Petite(1-2)



2052
Petite(11-12)

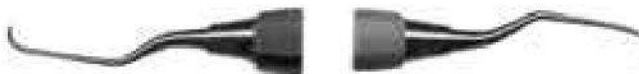

2053
Petite(5-6)



2054
Petite(13-14)



Curettes



2055
BARNHART (1-2)



2056
BARNHART (5-6)

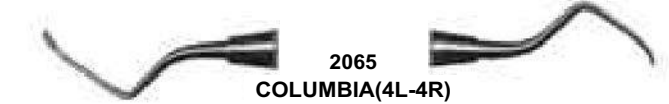

2065
COLUMBIA(4L-4R)

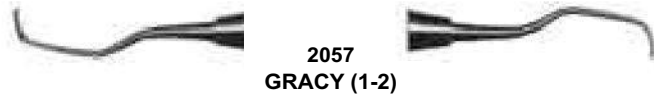

2057
GRACY (1-2)

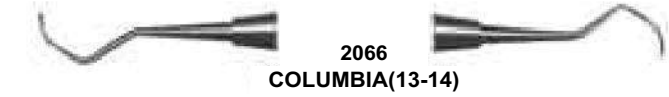

2066
COLUMBIA(13-14)

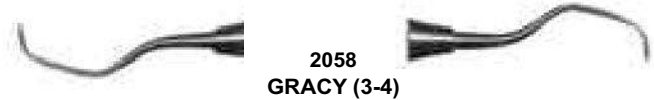

2058
GRACY (3-4)



2067
LANGER (1-2)

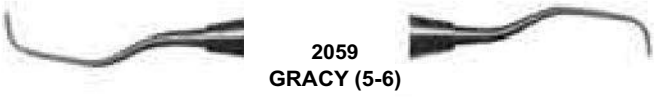

2059
GRACY (5-6)



2068
LANGER (3-4)

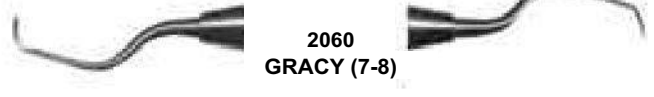

2060
GRACY (7-8)



2069
LANGER (5-6)

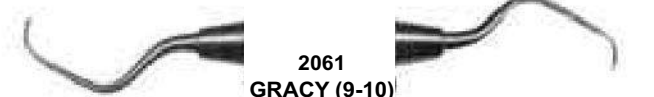

2061
GRACY (9-10)

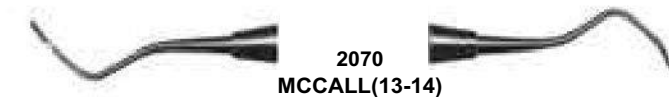

2070
MCCALL(13-14)

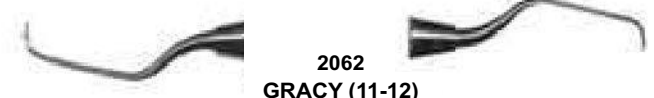

2062
GRACY (11-12)

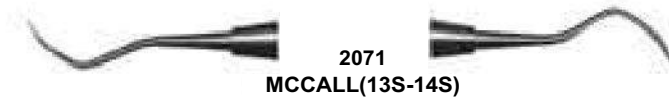

2071
MCCALL(13S-14S)

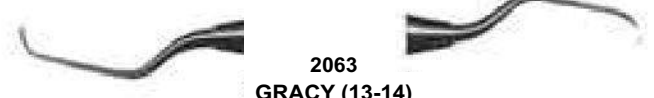

2063
GRACY (13-14)

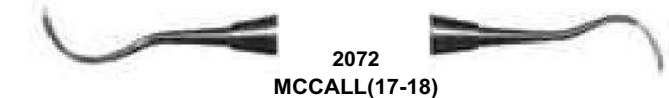

2072
MCCALL(17-18)

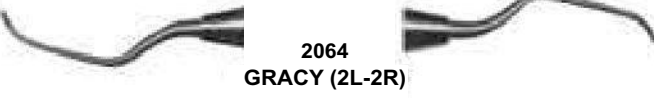

2064
GRACY (2L-2R)

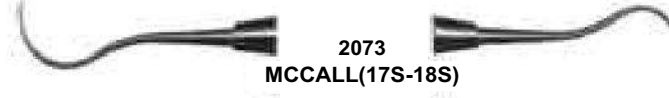

2073
MCCALL(17S-18S)



2074
RULE (3-4)

Section - 04

- Cement Instruments • Spatulas
- Knives • Bone Currettes & Files
- Bone Chisels • Bone Mallets
- Crown Remover
- Implant Instruments





Dental Products

Silicon Handles-Reusable

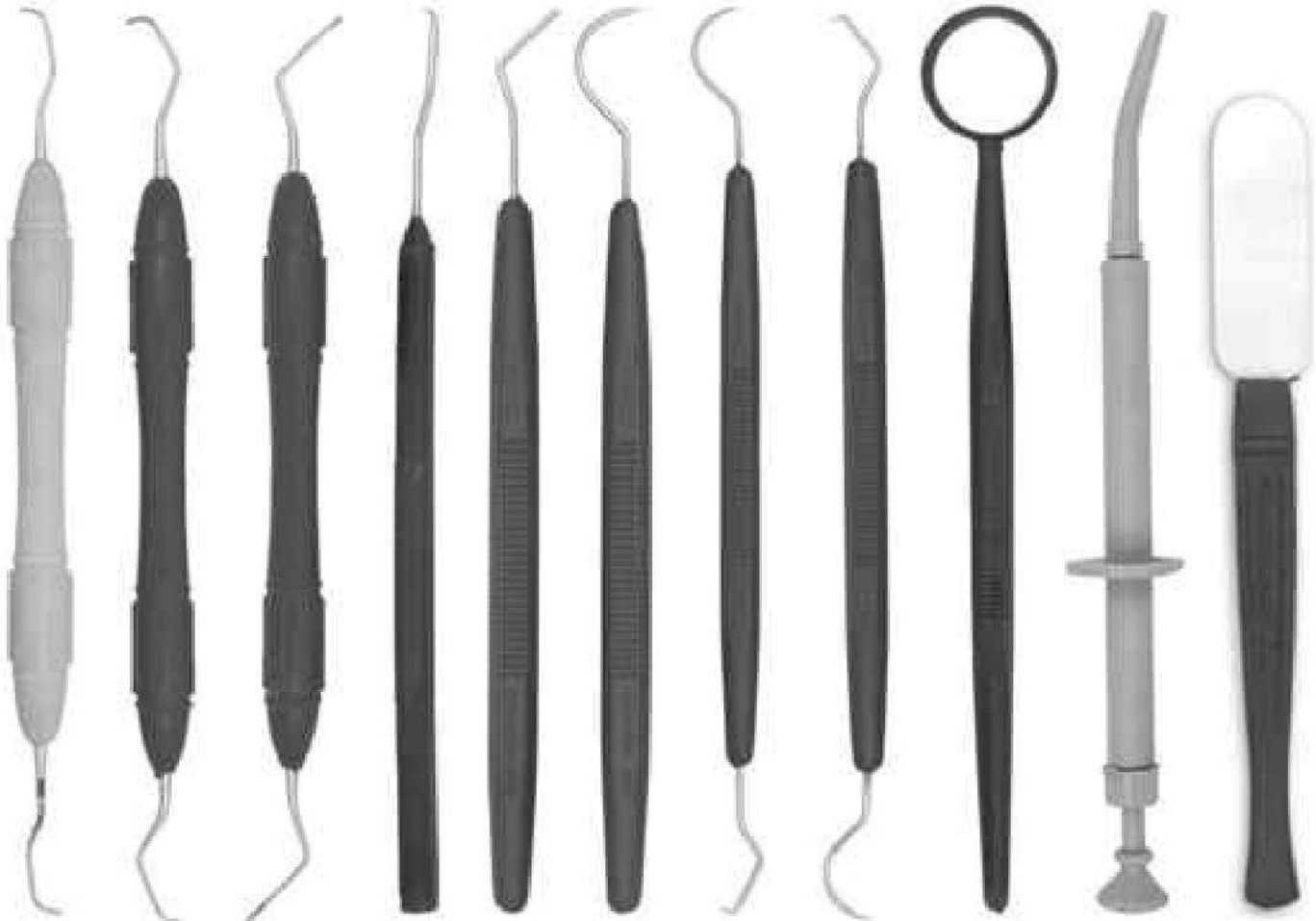

2075

2076

2077

2078

2079

2080

2081

2082

2083

2084

2085



2086

2087

2088

2089

2090



Wax, Porcelain & Cement Instruments

Comfort Grip
Vinyl - Covered Insulating Handles

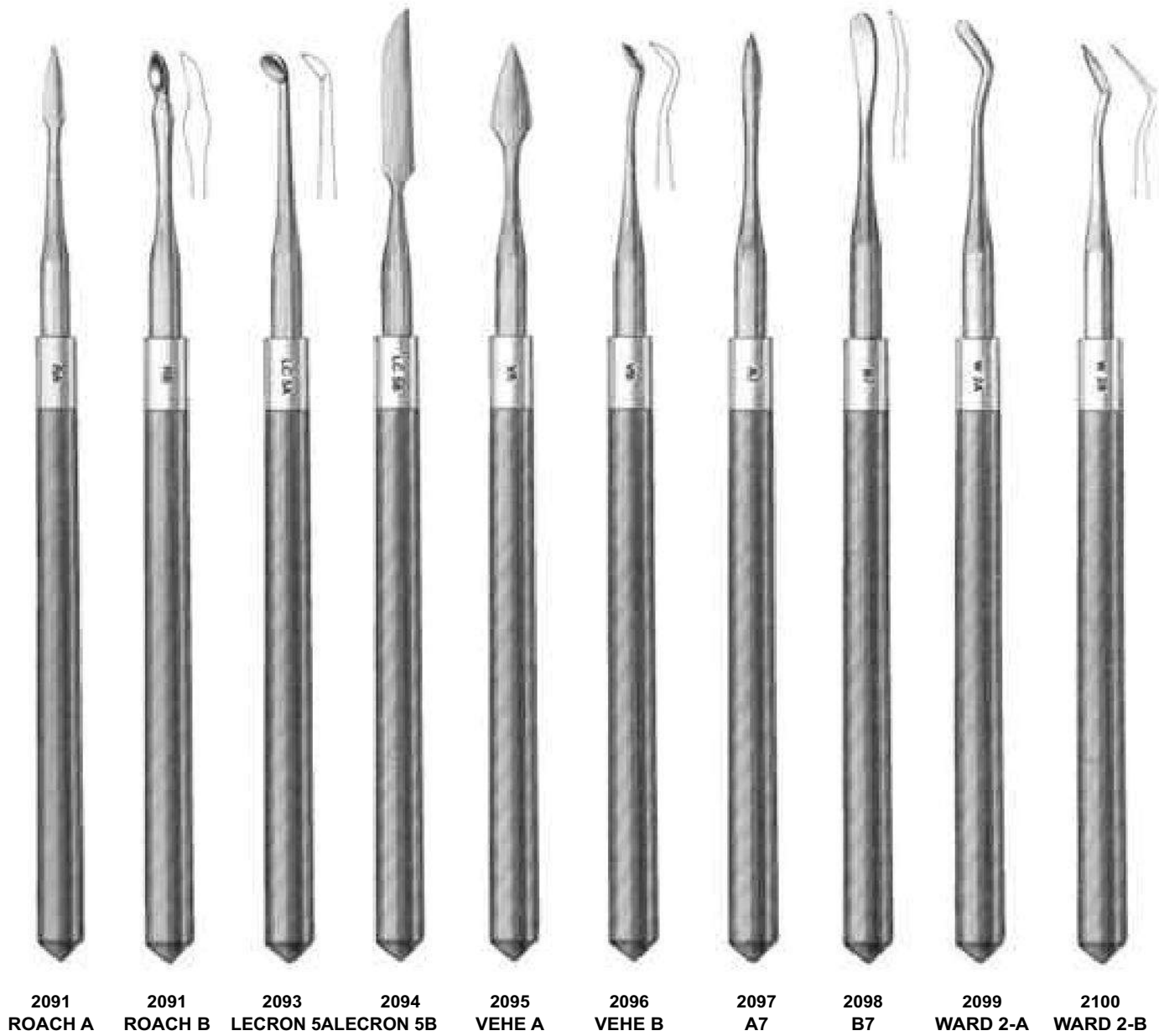

2091 ROACH A 2091 ROACH B 2093 LECRON 5A 2094 LECRON 5B 2095 VEHE A 2096 VEHE B 2097 A7 2098 B7 2099 WARD 2-A 2100 WARD 2-B



Wax, Porcelain & Cement Instruments

P.K. THOMAS

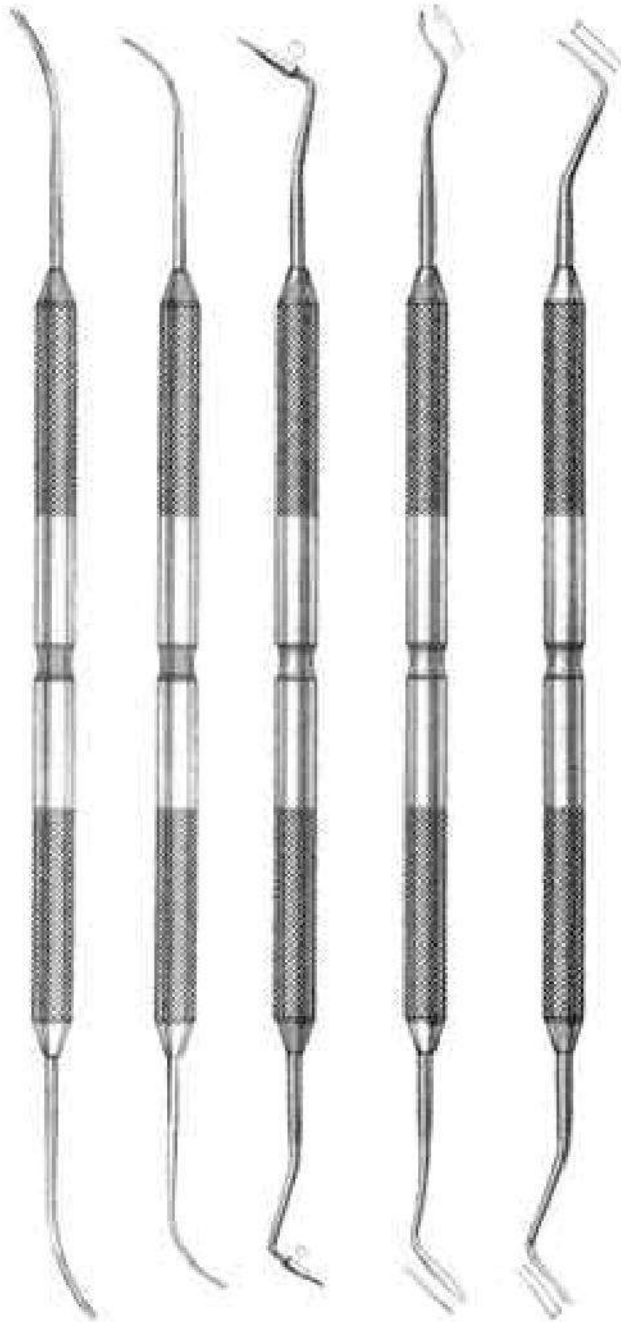

- 2101
PKT1
- 2102
PKT2
- 2103
PKT3
- 2104
PKT4
- 2105
PKT5

Set of 5 Instruments

WAX CARVERS

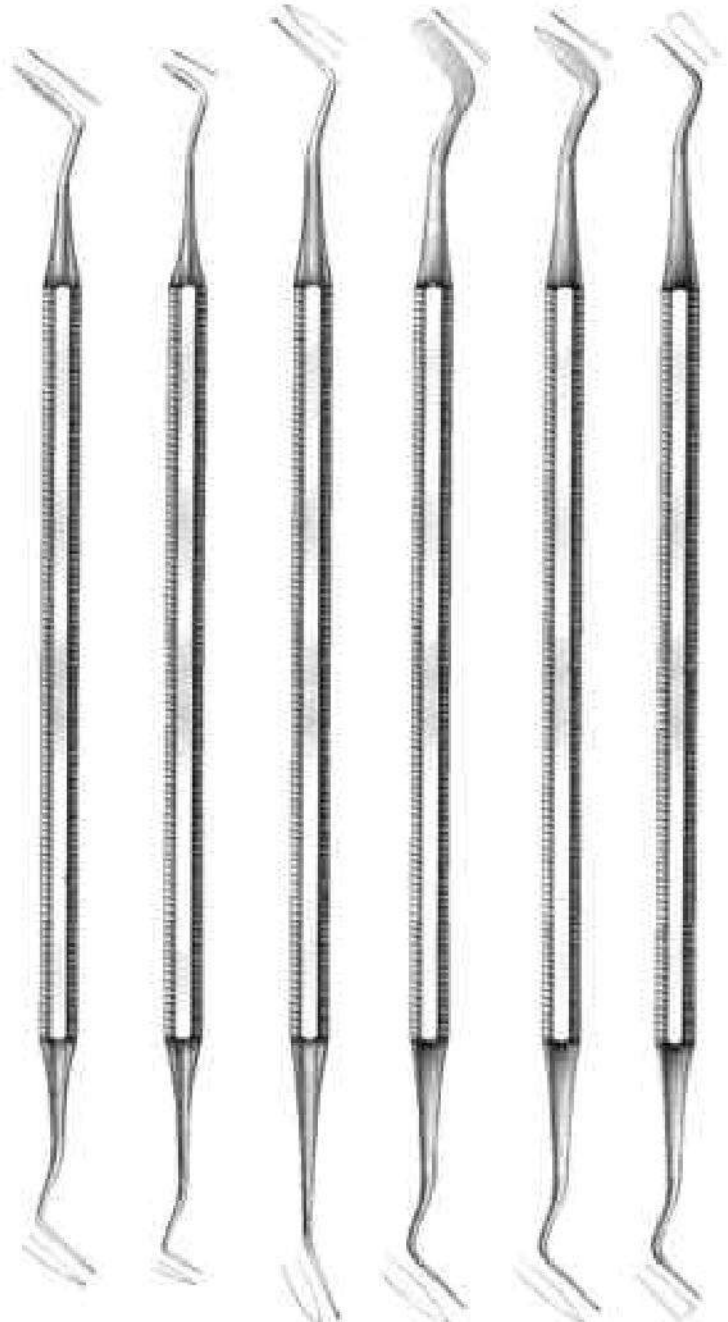

- 2106
Hollenback 3
- 2107
Hollenback 3S
- 2108
WARD 1
- 2109
WARD 2
- 2110
WALL 1
- 2111
WALL 3



**Wax, Modeling Carvers
Cement Spatulas**

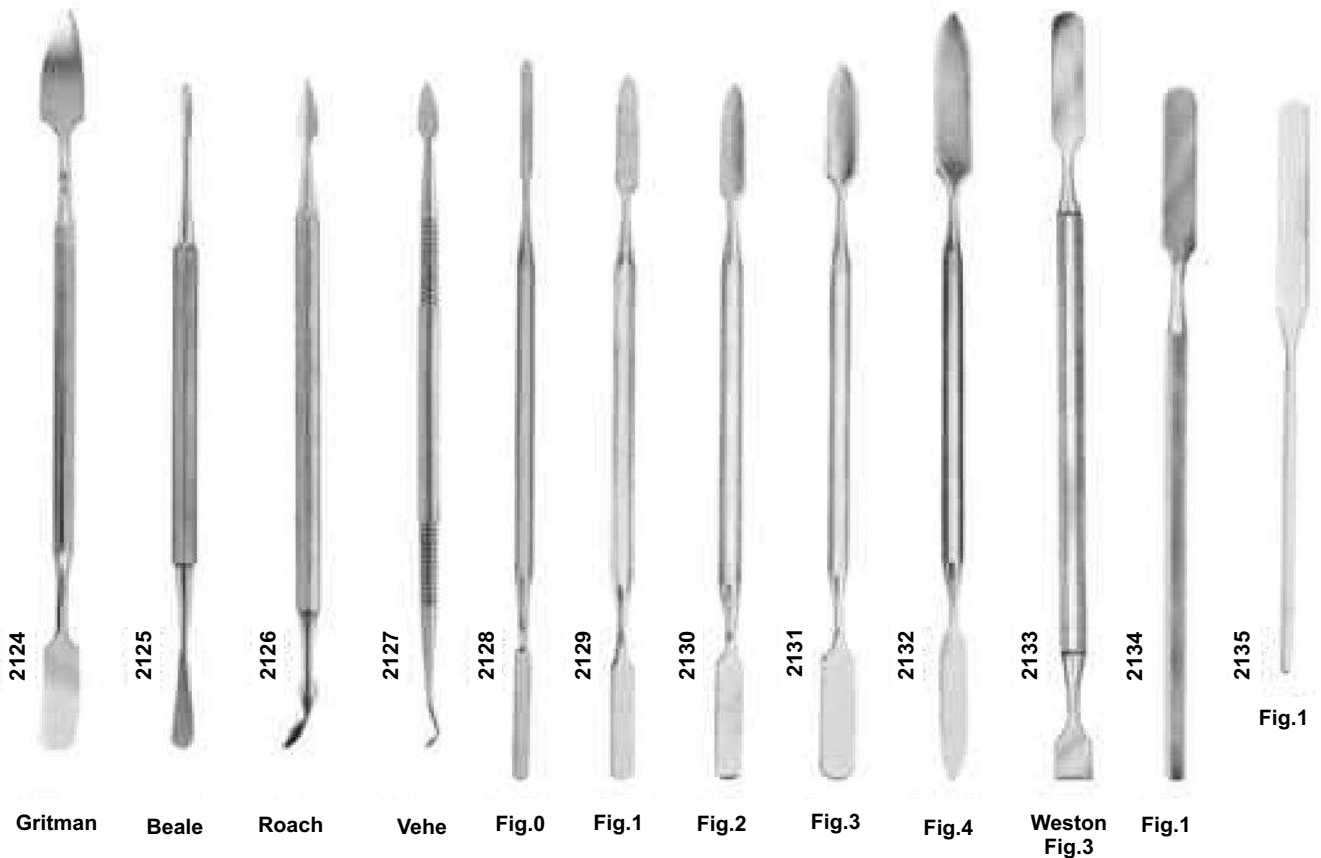
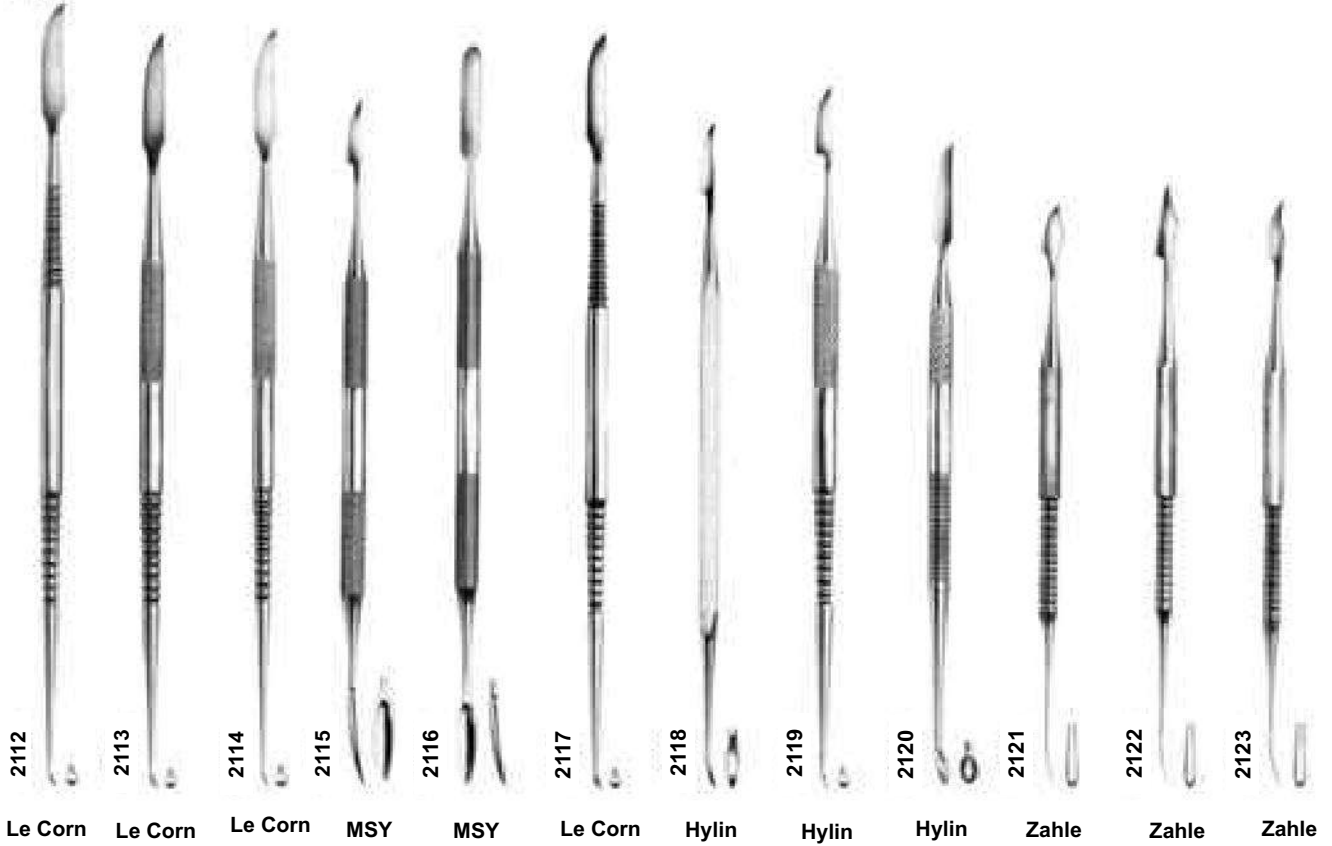



Wax, Porcelain & Cement Instruments

WAX & PORCELAIN CARVERS



2136
LECRO
N Inlay

2137
REEVES

2138
VEH
E
Wax

2139
ROAC
H Wax

WAX SPATULAS



2140
W-31

2141
W-5

2142
W-7

2143
W-7A

2144
W-7G



Cement Spatulas



2145
AGATHE



2146
C-7



2147
C-5



2148
C-313



2149
C-24A Rigid



2150
C-24 Flexible

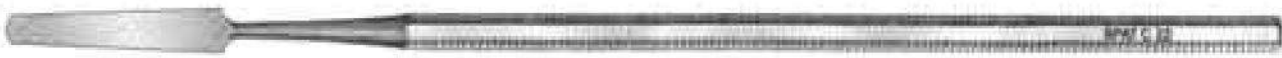

2151
C-24 Flexible



2152
24



2153
A6



2154
7 Wax



2155
26



2156
All Metal Spatulas With High Polish
Stainless Steel Blade

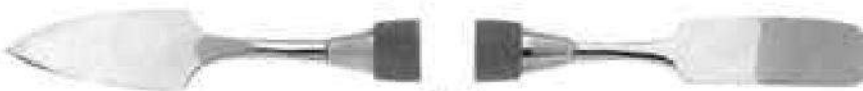

2157
31



Spatulas

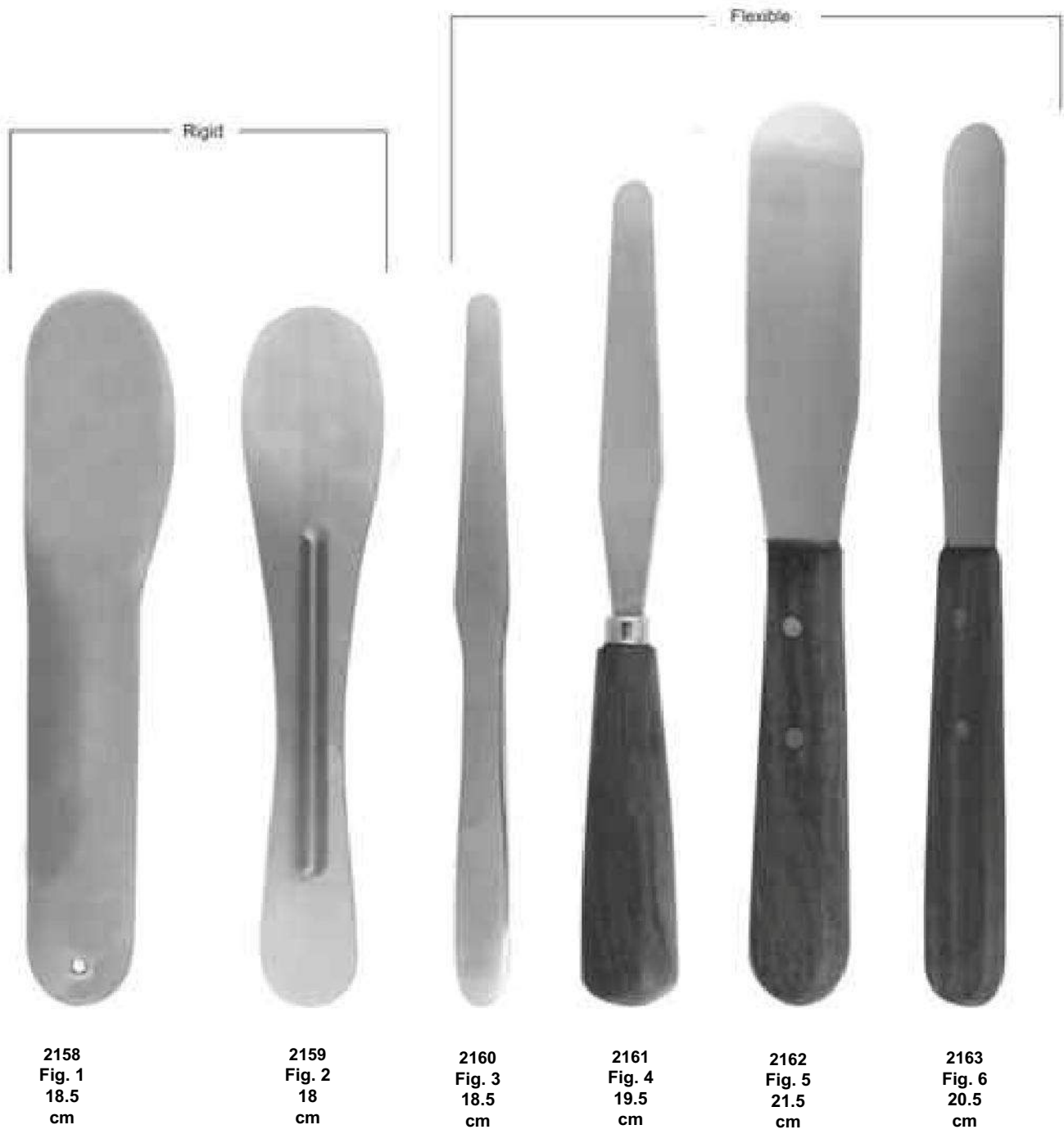



Spatulas





Files, Hoes & Knives

FILES

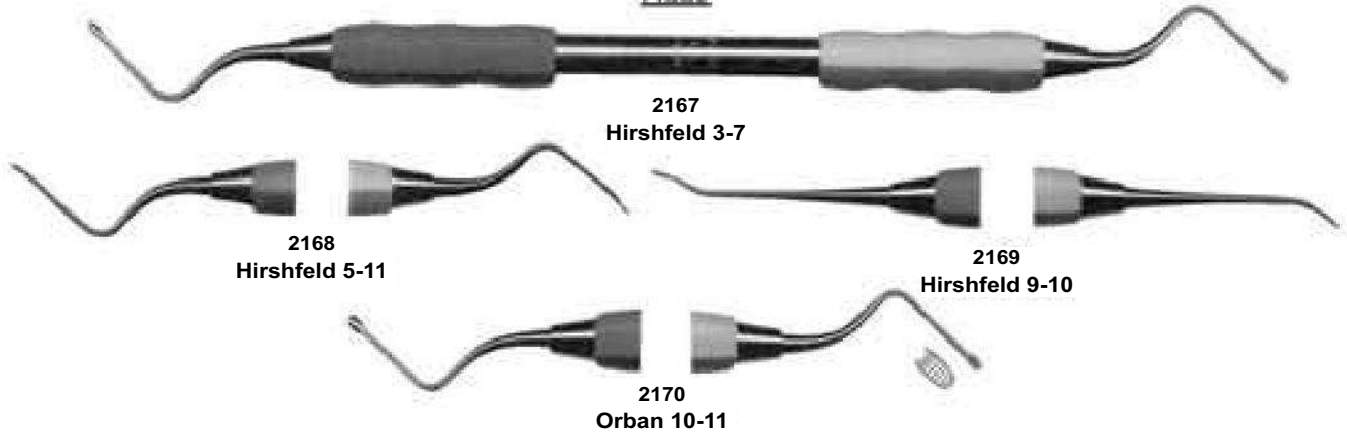

HOES

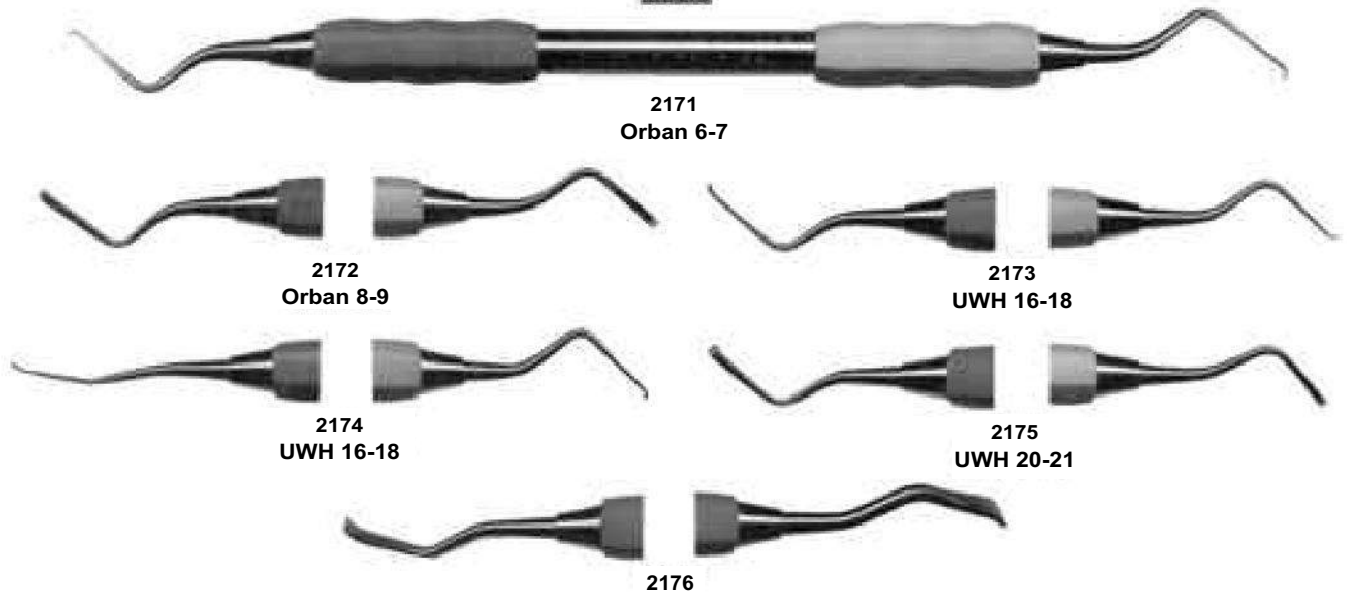

KNIVES

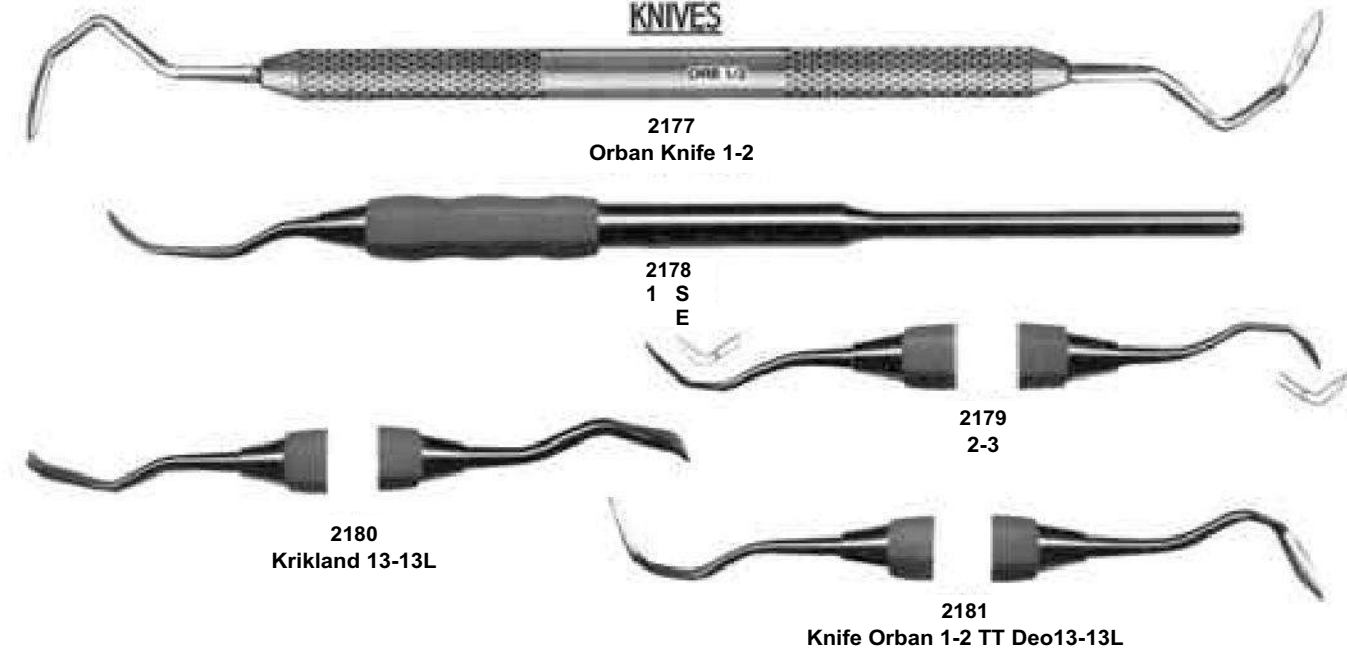



Wax Knives



2182
Fahnenstock
Fig. 1
12.5cm

2183
Fahnenstock
Fig. 2 17cm

2184
Lessma
n Fig. 1
12.5cm

2185
Lessma
n Fig. 2
17cm

2186
Con scodellino
Fig. 1
12.5 cm

2187
Con scodellino
Fig. 2
17 cm

2188
Emert

2189
Emert



Wax Knives & Plaster Knives



2190
18cm



2191
18cm



2192
17cm



2193
17cm



2194
Fig1
17c
m



2195
22 cm



2196
22 cm



2197
Gritman
Fig 3
17 cm



2198
Fig 3
16
cm



2199
Fig 4
16
cm



Crane-Kaplan, Chisels

CRANE-KAPLAN



2200
Ck1 Pocket
Marker



2201
Ck2 Pocket
Marker



2202
Knife



2203
Dissector

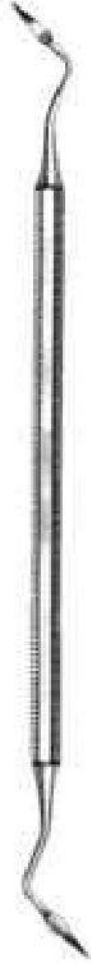

2204
Scaler

OCHSENBEIN



2205
Ochsenbein
Fig 1



2206
Ochsenbein
Fig 2

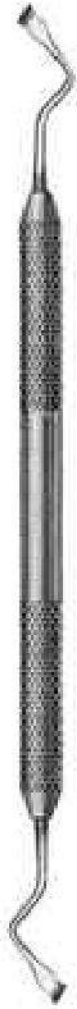

2207
Ochsenbein
Fig 4



Split Chisel Set



2208
Split Chisel
6mm
Curved

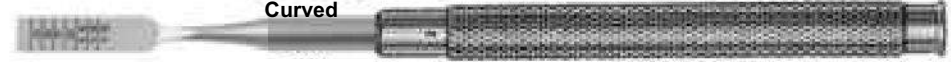

2209
Split Chisel
6mm
Straight



2210
Split Chisel
4mm
Curved



2211
Split Chisel
4mm
Straight



Bone Curettes

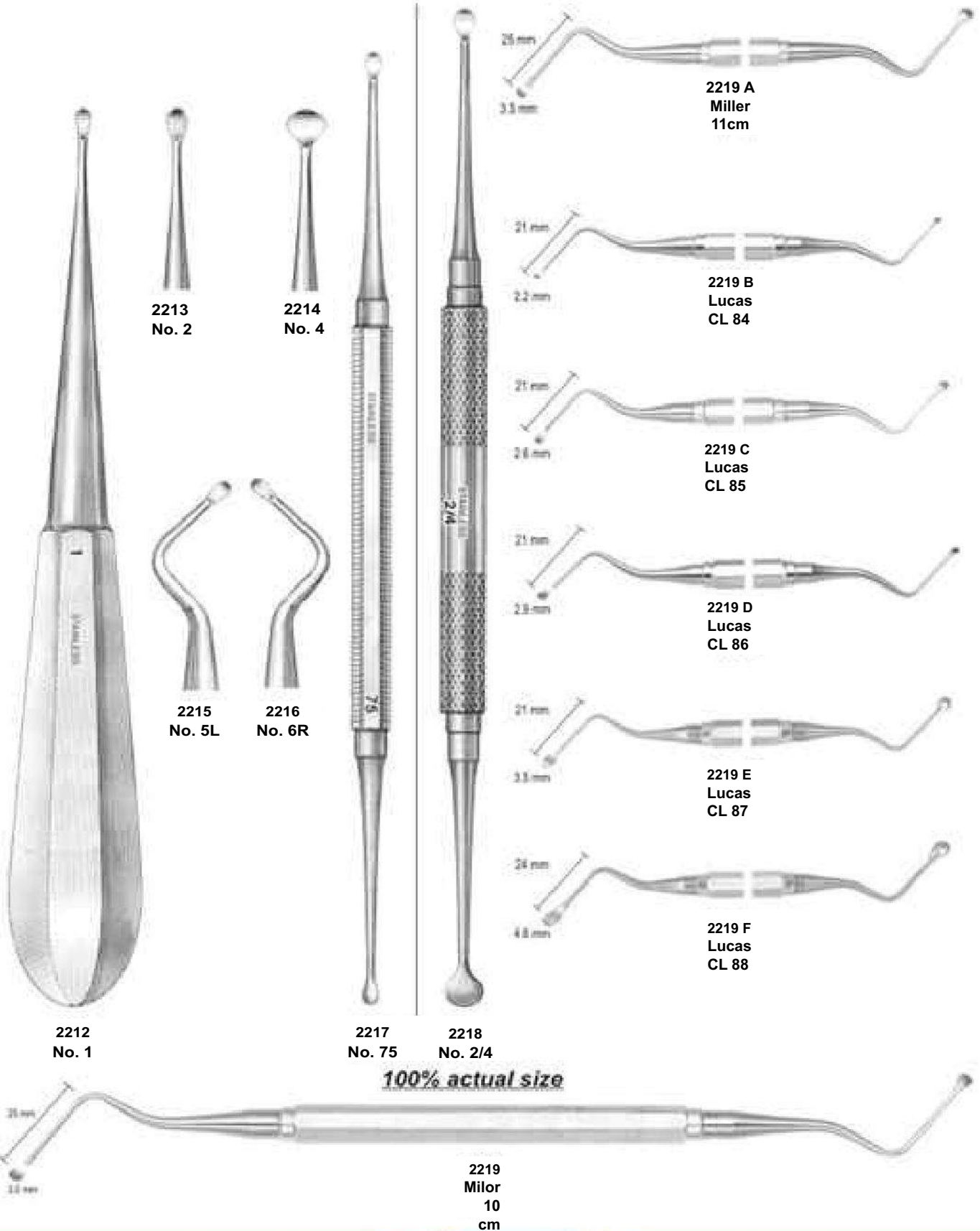



Bone Files

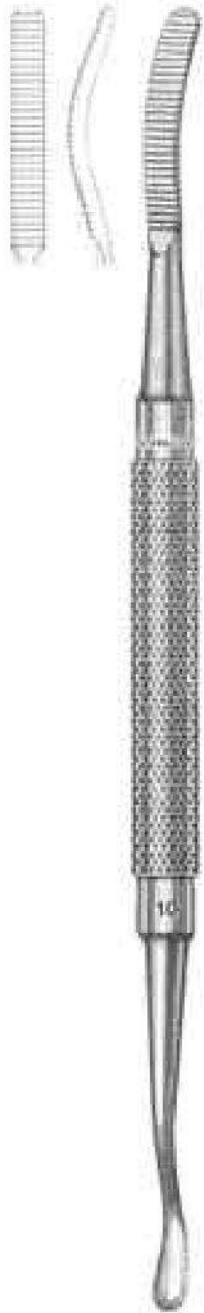

2220
No. 10

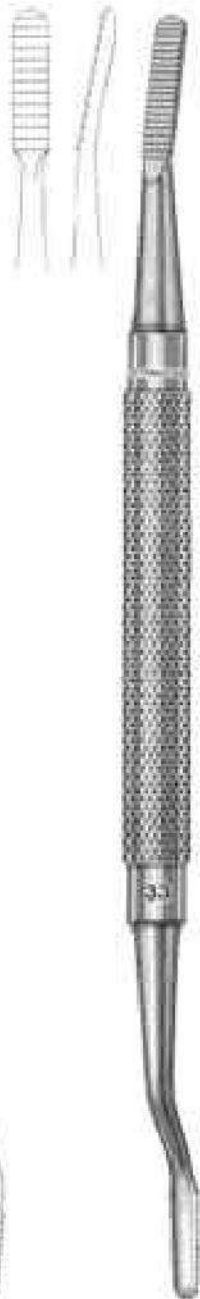

2221
No. 33

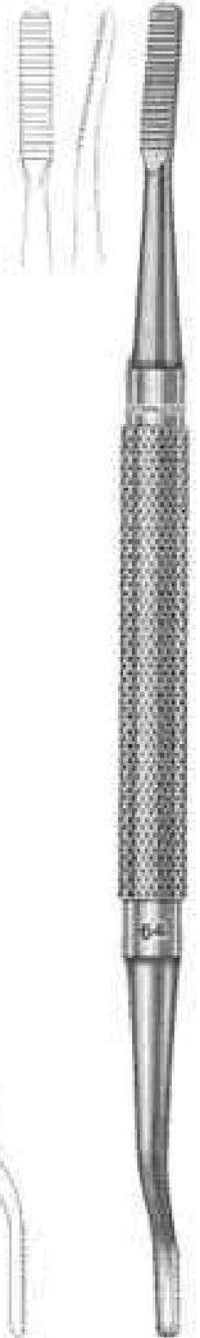

2222
MILLER
No. 33

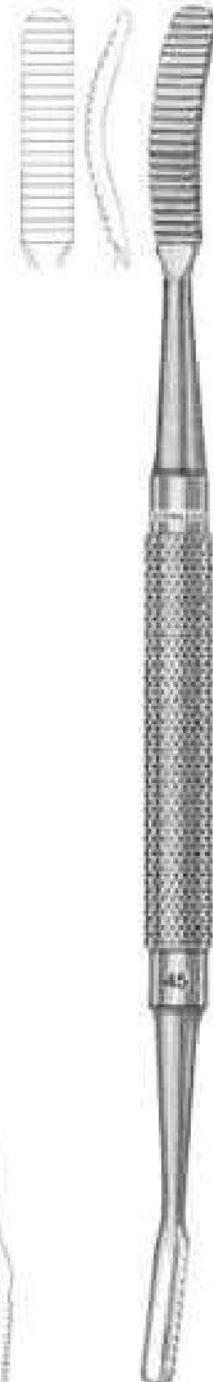

2223
MILLER
No. 64



Bone Files

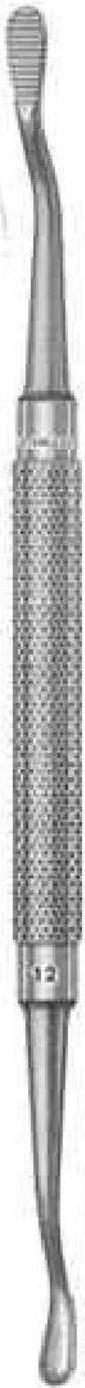
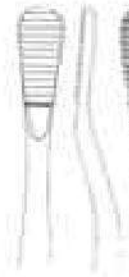

**2224
HOWAR
D NO. 12**

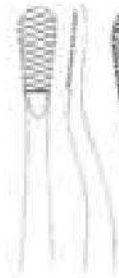

**2225
HOWAR
D NO.
12A**

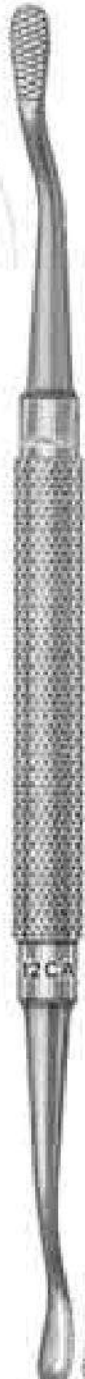

**2226
HOWARD
NO.
12CA**



**2227
POLOKOFF
NO. 1**





Bone Chisels

GARDNER



2228
GARDNE
R No. 1

2229
GARDNE
R No. 2

2230
GARDNE
R No. 5

2231
GARDNE
R No. 5R

WAKEFIELD



2232
WAKEFIELD
No. 1W

2233
WAKEFIELD
No. 2W



Bone Chisels Bone Mallets

Bone Chisels and Gouges

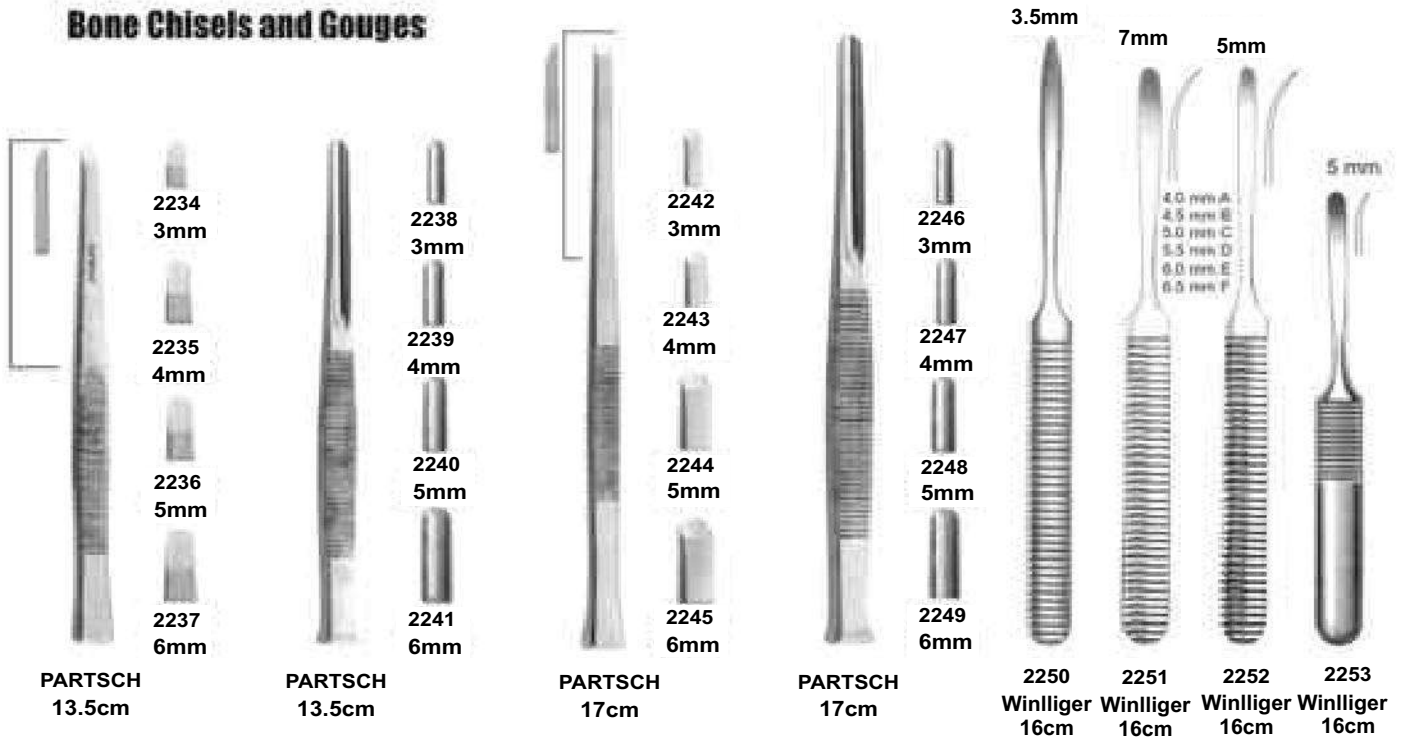

Martelli chirurgici Mallet

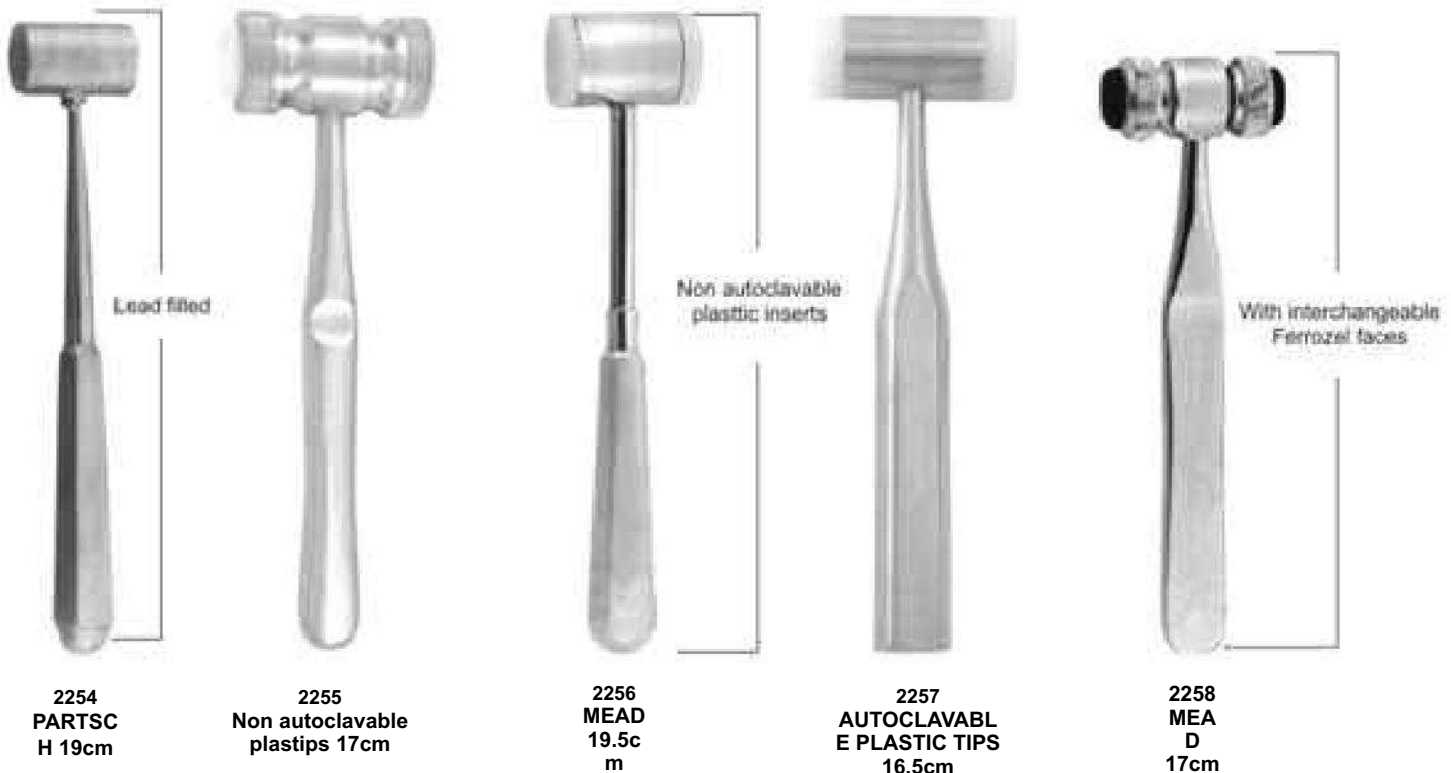



Crown Removers

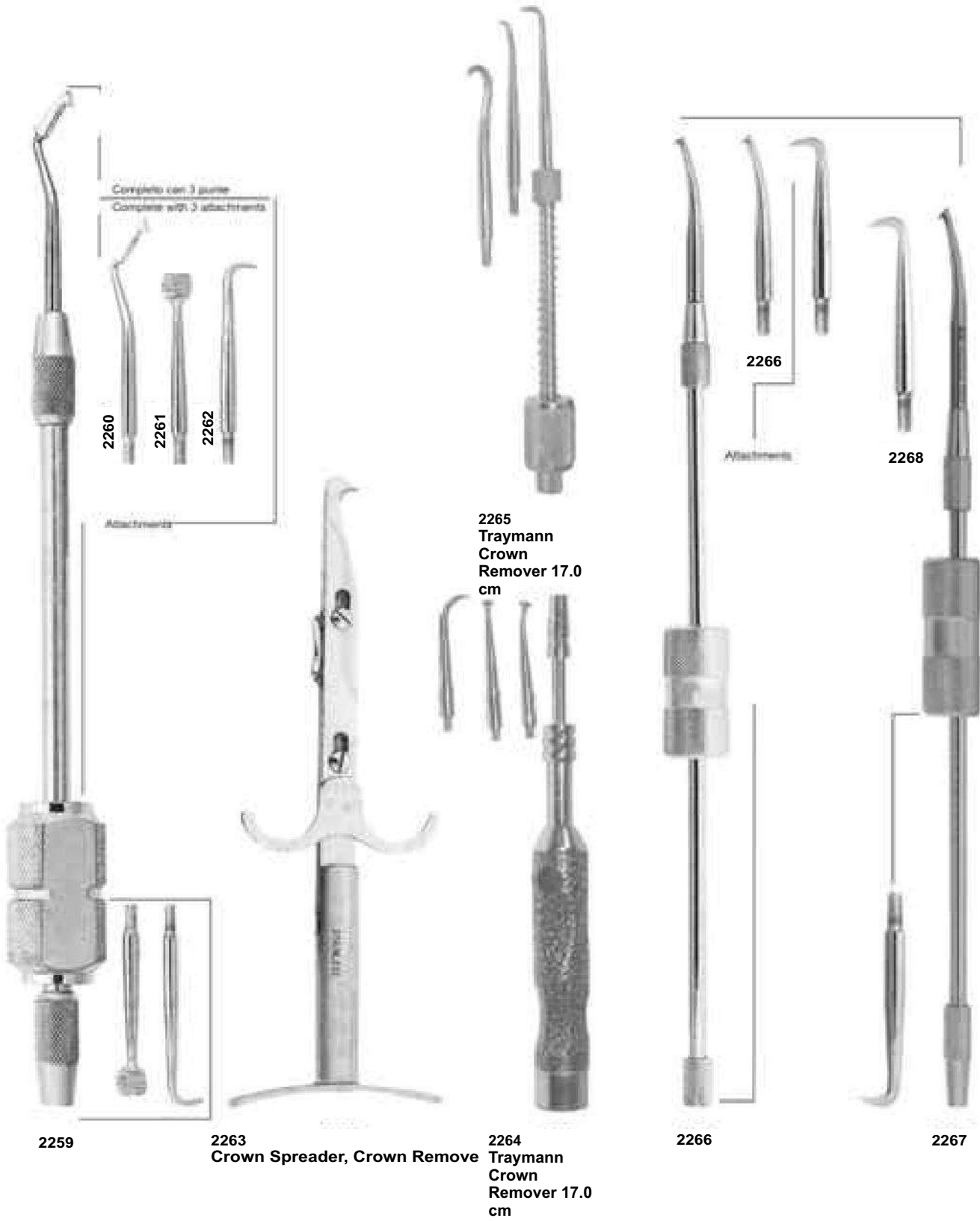



Crown Instruments



2269
Crown Remover

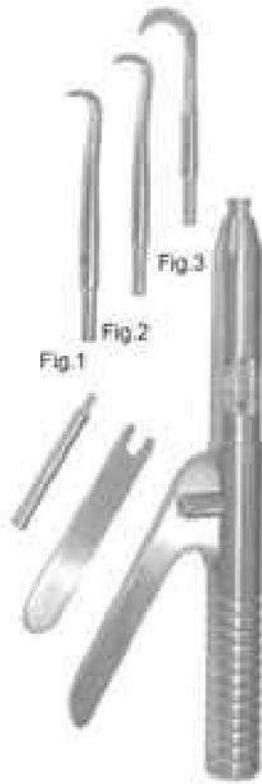

2270
Crown Remover



2271
Single loop
with adapter

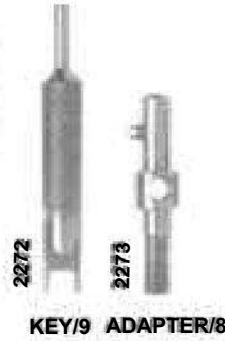

2272
2273
KEY/9 ADAPTER/8



2274
Crown & Bridge Holding Forceps
With Support Ring



2276
Crown Opener

2275
WYNMAN
Crown Gripper, CARB N
SERT



2277
Mershon
14.5cm



2278
Universal
Hollow Handle

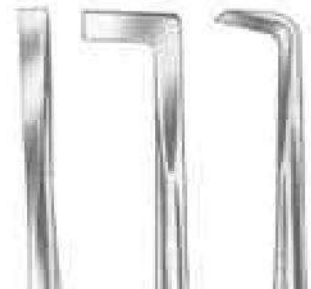

2279 Fig.2
2280 Fig.3
2281 Fig.3





Crown Instruments



2282
Plaster
Shear
210mm

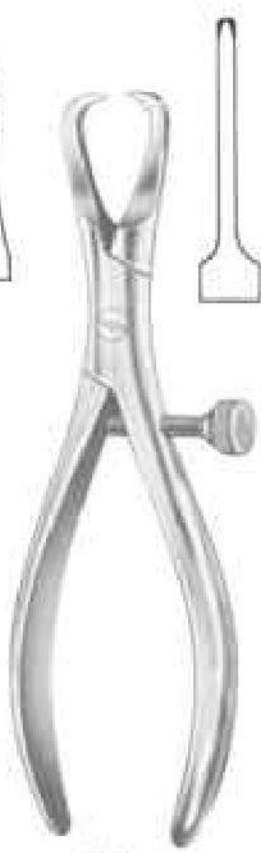

2283
Crown Removing Plier
14 cm



2284
MONTFORT
18 cm



2285
BOH
M 16
cm

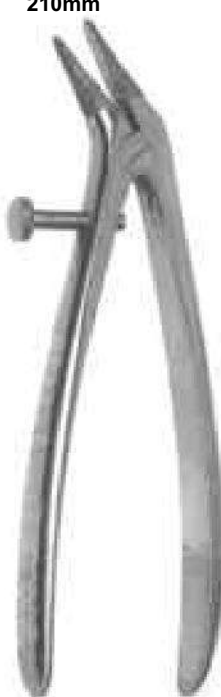

2286
Telescope Crown
Plier Diamond coated
13 cm



2287
Telescope Crown
Plier Diamond coated
13 cm

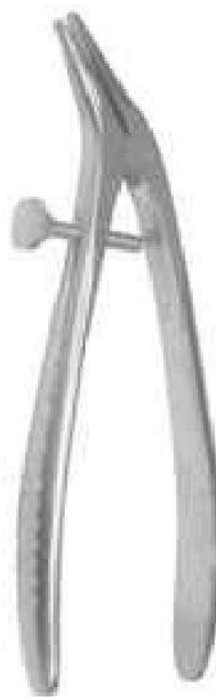

2288
Telescope Crown Plier
13 cm gerieften Maul
13 cm gelatts Maul
15 cm gelatts Maul



2289
Telescope Crown
Plier Fine
15.0 cm



Implants Instruments



2290
1P
150
mm



2291
Fig1
155
mm

Ø 2 mm



1P
150 mm

Ø 2.7 mm

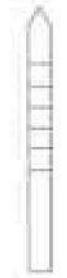

2P
150 mm

Ø 3.25 mm



3P
150 mm

Ø 3.8 mm

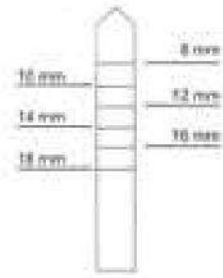

4P
150 mm

Ø 3 mm



1T
150 mm

Ø 4 mm

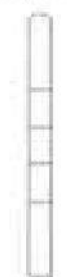

2T
150 mm

Ø 5 mm



3T
150 mm

Ø 1.60 mm



1
155 mm

Ø 1.90 mm



2
155 mm

Ø 2.80 mm



3
155 mm



4
155 mm



5
155 mm



6
155 mm



Implants Instruments



2292
Fig1B
165
mm

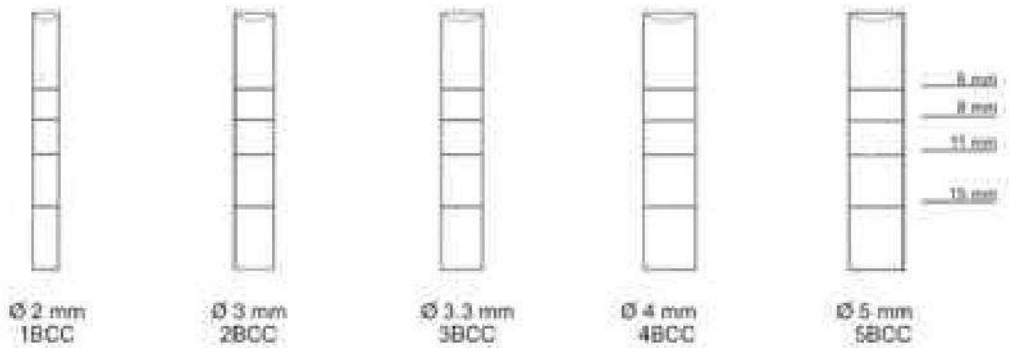
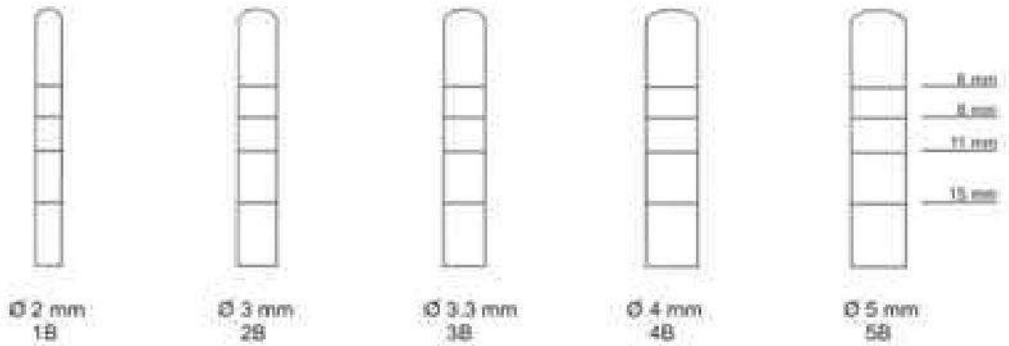

2293
Fig1
155
mm

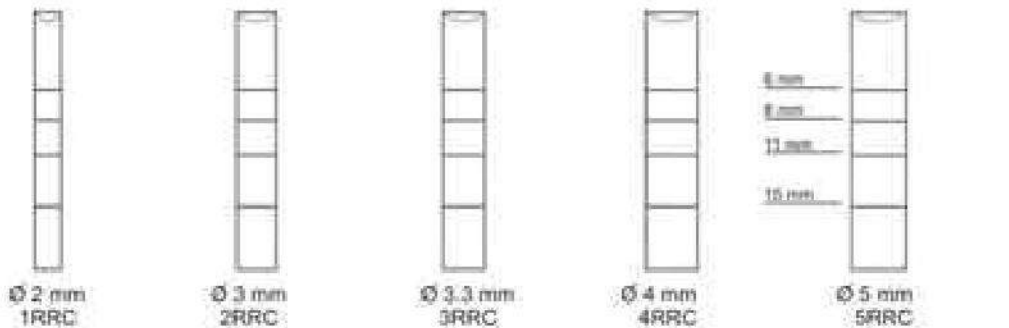
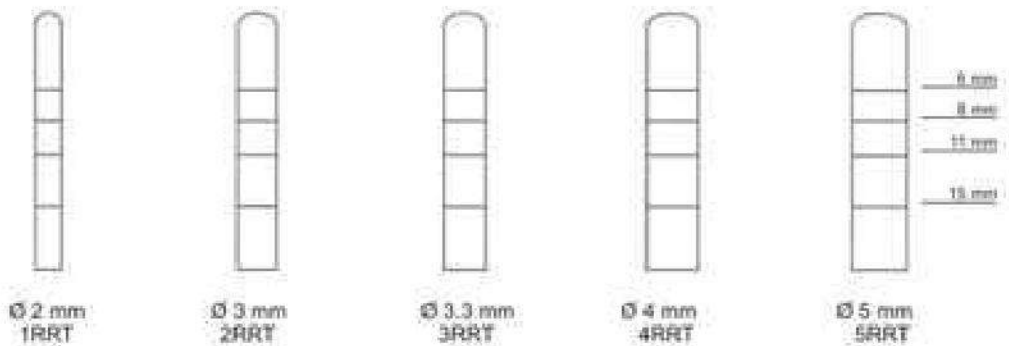



Implants Instruments

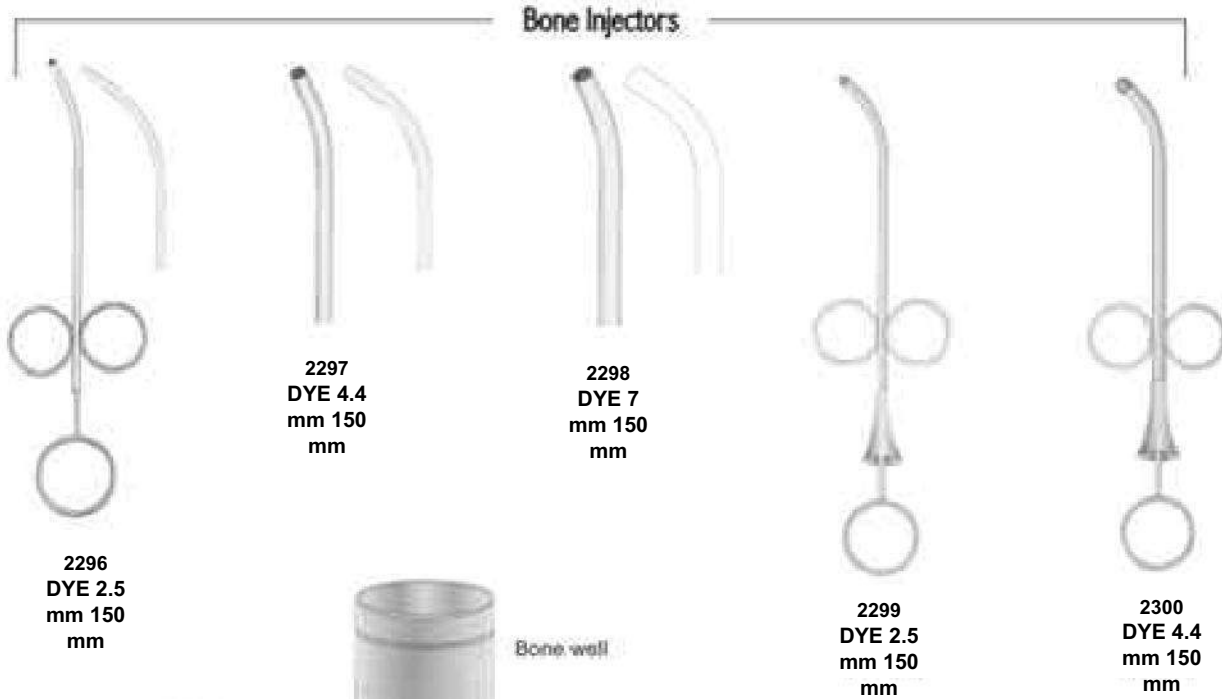
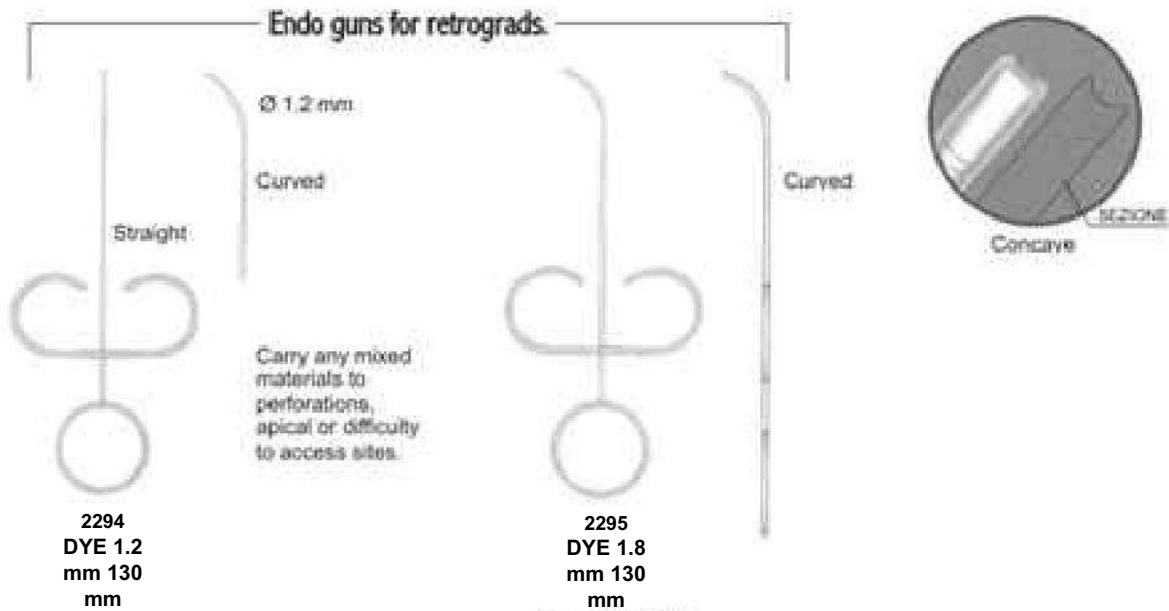

2302
Grinders for autogenius

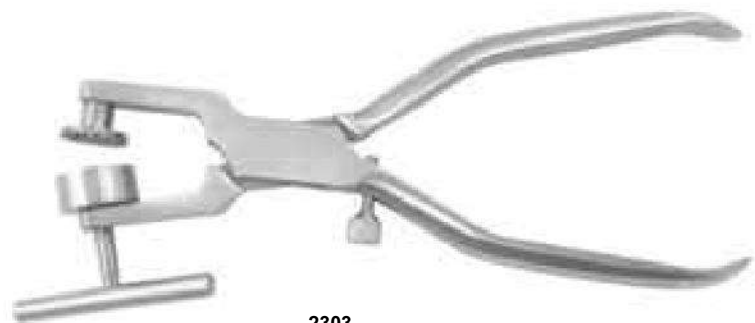



**Suction tubes, Bone Pluggers
Rongeurs**

Suction Tubes



Bone Pluggers



Kerrison Rongeurs

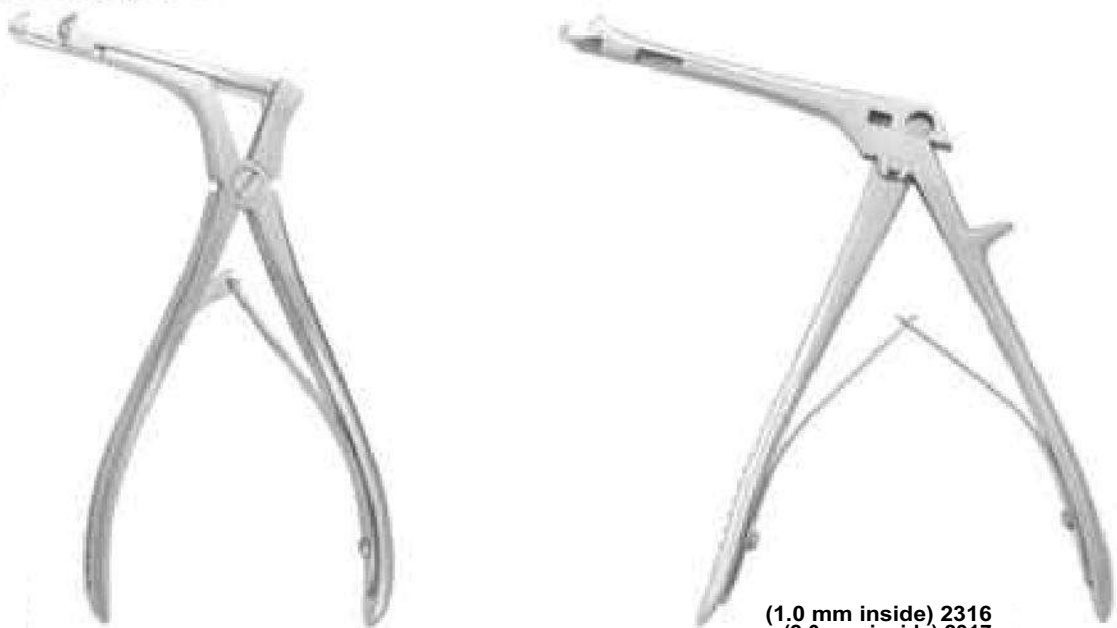

(1.5 mm inside) 2311
 (2.0 mm inside) 2312
 (3.0 mm inside) 2313
 (4.0 mm inside) 2314
 (4.5 mm inside) 2315
 16.5 cm

(1.0 mm inside) 2316
 (2.0 mm inside) 2317
 (2.5 mm inside) 2318
 16.5 cm



Implants Instruments



2319
Fig. 1
170m
m

2320
Fig. 2
175m
m

2321
Fig. 3
170m
m

2322
LUCAS
Fig. 88
170m
m



Bone Compactors

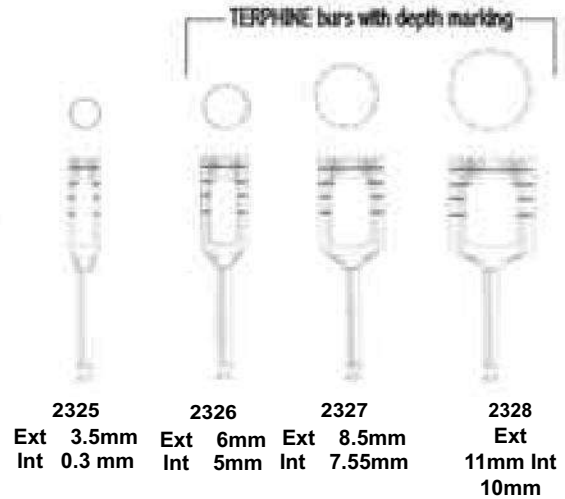

2325	2326	2327	2328
Ext 3.5mm	Ext 6mm	Ext 8.5mm	Ext 11mm
Int 0.3 mm	Int 5mm	Int 7.55mm	Int 10mm

Sinus lift instruments



2329
Fig. 1

2330
Fig. 2

2331
Fig. 3

2332
Fig. 4

2333
Fig. 5

2334
Fig. 6

2335
Fig. 7

2336
Fig. 8

2337
Fig. 9



Suction Tubes

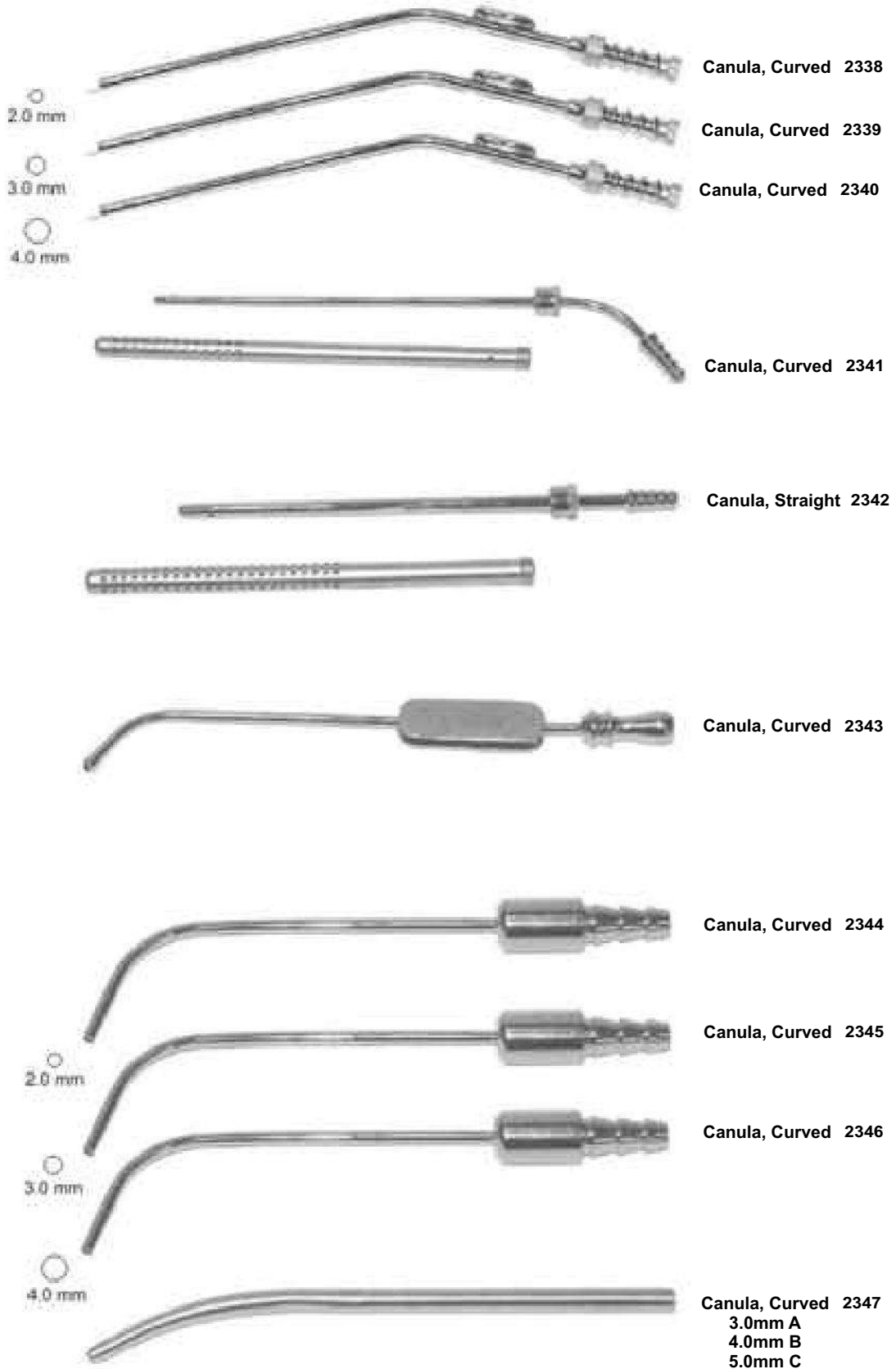

Section - 05

- ★ Measuring Instruments
- ★ Amalgam Guns & Carriers
- ★ Retainers
- ★ Rubber Dam Instruments
- ★ Syringes ★ Tweezers
- ★ Sterilizing & Lab. Instruments

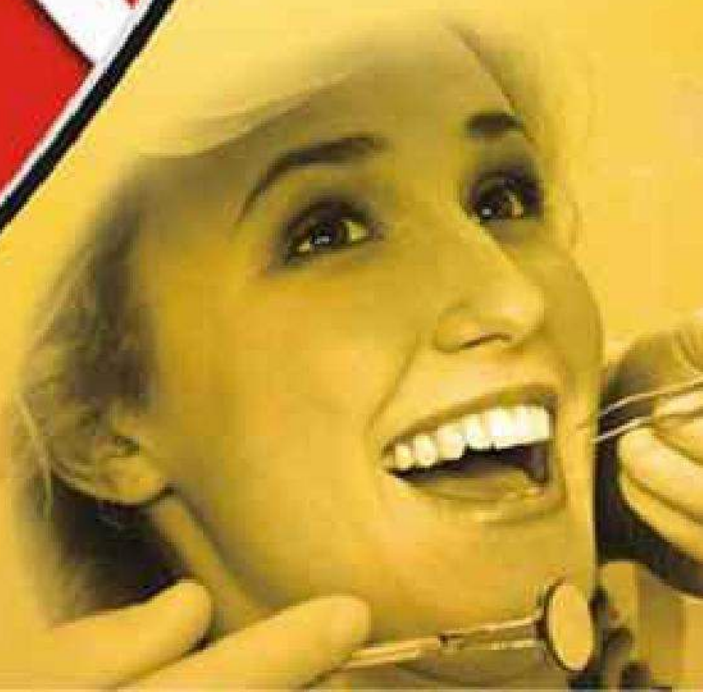



Measuring Instruments



2348
BOLEY Guage

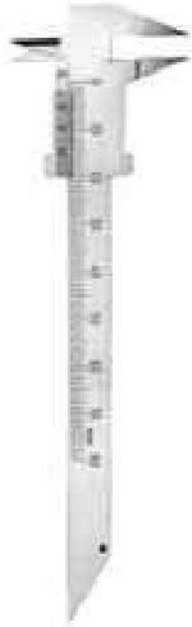

2349
ZURICHE
R 130mm



2350
VERNIE
R 12cm

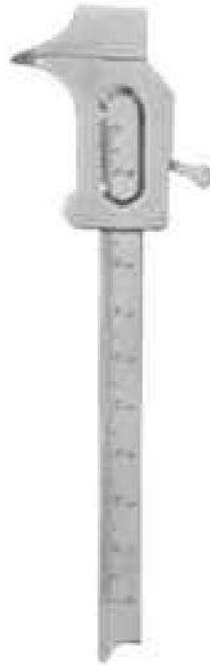

2351
VERNIER



2352
VERNIER Guage

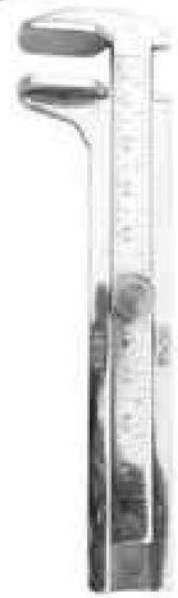

2353
VERNIER Guage



2355
Finger Ruler



2354
LAWANSON
Crown Guage

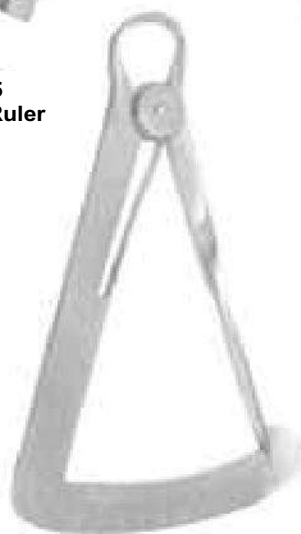

2356
LAWANSON
Crown Guage



2357
Spring Guage
10 cm



2358
Spring Bow Divider
6" Radius



2359
VERNIER
Guage



2360
ALBEE



2361 Height
Guage Wick
Type



Bone Gauge & Measuring Instruments



2362
Bone Gauge



2363
Bone Calliper
15cm



2364
Casterviejo



2365 A
Casterviej
o Curved



2365 B
Straight

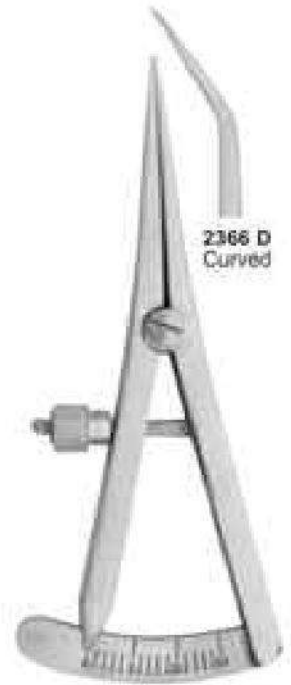

2366 C
Casterviej
o Straight



2366 D
Curved



2367
Guage

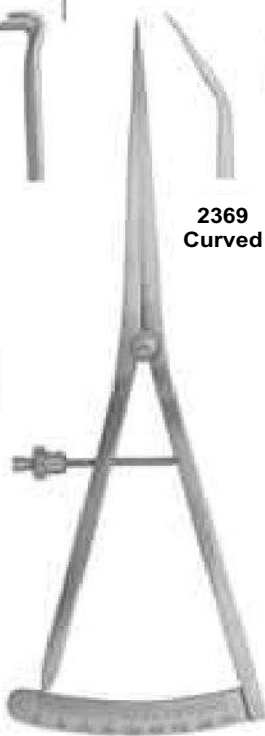

2368
Castroviej
o Straight



2369
Curved



2370 A

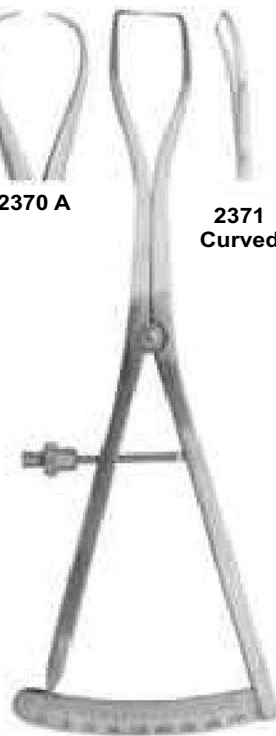

2370
Castroviej
o Straight



2371
Curved



2373
BOOne Guage

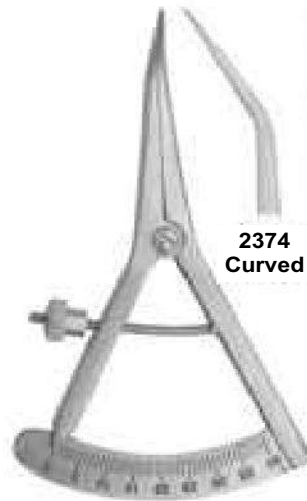

2372
Castroviejo

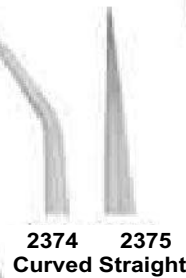

2374
Curved



2375
Straight



2376
Bracket Guage, Ant /Post





Amalgam Guns & Carriers



2377
Medium Large
20cm



2378
Medium Jumbo
20cm



2379
Large Jumbo
20cm



2380
Jumbo Jumbo
20cm



2381
Regular Jumbo
Silicon Grip
20cm



Ø2 mm
2382
Medium
15.5cm



Ø2.5 mm
2383
Large
15.5cm



Ø3 mm
2384
Jumbo
15.5cm



2385
145mm



2386
130mm



Ø2 mm



2387
Straight
15cm

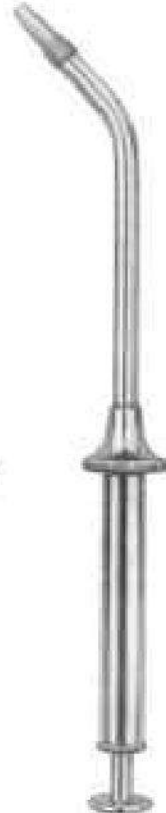

2388
15 cm

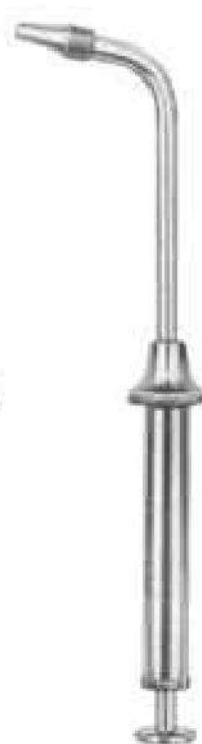

2389
15 cm



2390
Amalgam Well
Non stick
Base 3.5mm



**Retainers, Bands, Strip Holder Clips,
Napkin Holder**

Retainers



2391
No. 1

2392
No. 8

2393
No. 9

"Tofflemire" Type Retainers

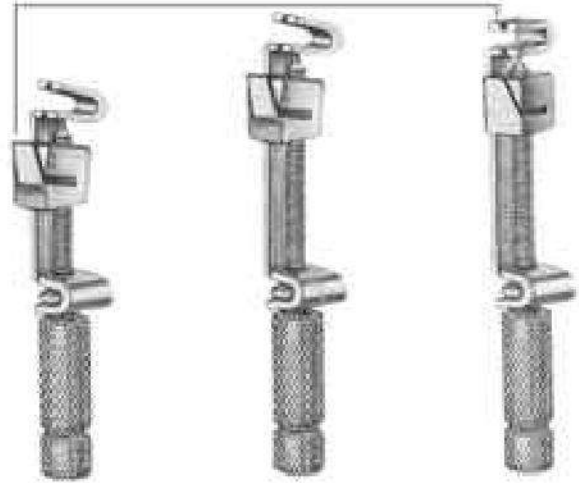

2394
SENIOR CA

2395
SENIOR CA

2396
UNIVERSAL

Tofflemire Bands

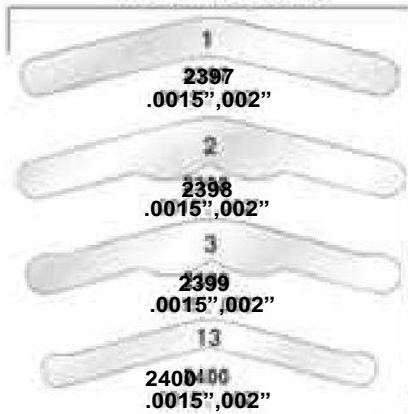

2397
.0015", .002"

2398
.0015", .002"

2399
.0015", .002"

2400
.0015", .002"

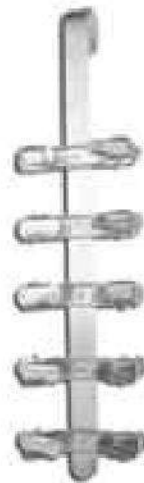

Set of 10
2402 Film
Hanger

Napkin Holders



2403
BALL CHAIN

2404 NON
CHILL Clear
Plastic

2401 X-Ray
Holder Small



Strip Holders

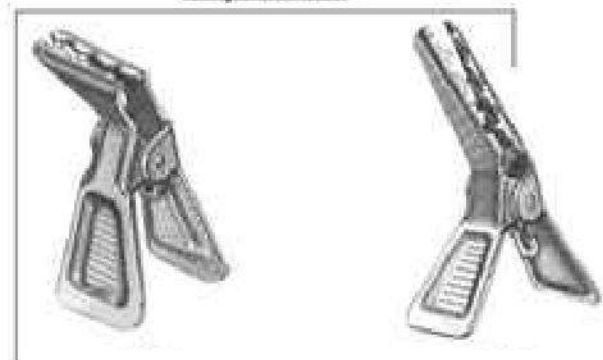

2408
Strip Holder Clip
90 D

2409
Strip Holder Clip
45 D

2405 Finger
Protector Small

2406
Medium

2407
Large



Rubber Dam Instruments



2410 IRORY
Leight Right
170mm



2411 BREWER
R
175mm

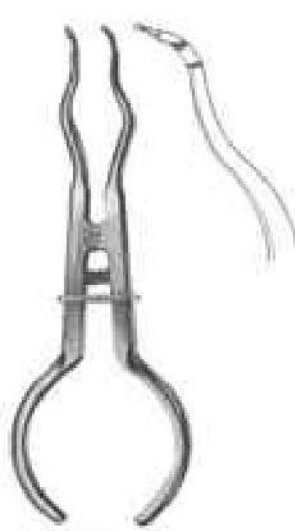

2412 BREWER
R
175mm



2413 WHITE
175mm

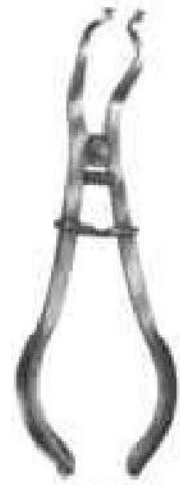

2414 IVORY
170mm



2415 AINSWORTH
Rubber Dam Punch
170mm



2416 AINSWORTH
Rubber Dam Punch
170mm



2417 AINSWORTH
Rubber Dam Punch
170mm

Articulating Paper Forceps



2421 MILLER
Articulating
Forceps
15cm



2422 MILLER
Articulating
Forceps
15cm

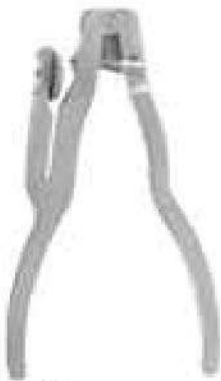

2418
Plastic Rubber Punch
160mm



2419
Plastic Rubber
Dam Frame 242



2420
Rubber Dam
Holder Stainless
Steel



Rubber Dam Clamps

LOWER MOLARS



2423
76D-W3



2424
76D-3



2429
76D-7A



2430
76D-7



2435
76D-12A



2436
76D-13A



2441
76D-26



2442
76D-28



2445
76D-W8A



2446
76D-8A



2447
76D-10



2448
76D-11



2451
76D-24



2452
76D-25

UPPER MOLARS



2425
76D-4



2426
76D-5



2431
76D-8



2432
76D-26N



2437
76D-30



2438
76D-31



2443
76D-201

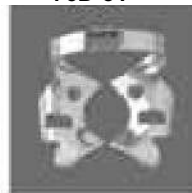

2444
205

MOLARS



2449
76D-14



2450
76D-118



2453
76D-27

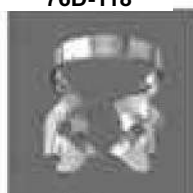

2454
76D-56



2455
76D-14A

PREMOLARS



2427
76D-0

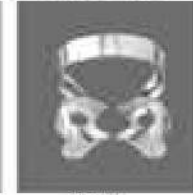

2428
76D-1



2433
76D-2A



2434
76D-2



2439
76D-27N

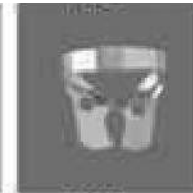

2440
76D-29

ANTERIOR



2456
76D-00



2457
76D-1A



2458
76D-9



2459
76D-212



Aspirating Syringes

4969/CO



4969/F



4969/CV

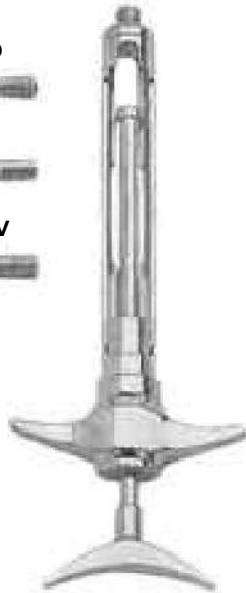

2460
MI 1.8
EU



2461
MI 1.8
EU/A
M



2462
MI 1.8
EU/A
M



2463
Fig.1
MI 1.8
EU

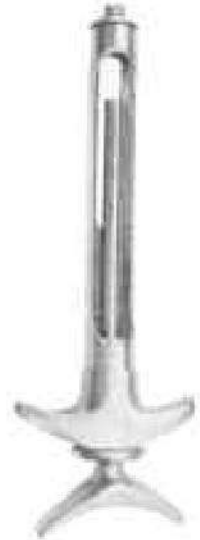

2464
Fig.1
MI 1.8
EU



2465
SS INOX
All Inox & autoclavable
black plastic handle
passive automatic aspiration



2466
Fig. 1
ml 1.8
EU/A
m



2467
Fig. 1
ml 1.8
EU/A
m



2468
Fig. 1
ml 1.8
EU/A
m



2469
MI 1,2
EU/A
m



Syringes



2470
Water Syringe
Complete with 1
cannula(luer-lock)



2471
Water Syringe
Complete with 1
cannula(luer-lock)



2472
Metal water
Syringe Self lling
with 1 cannula(luer-
lock)



2473
Sparrel Barrel with
Plunger suitable for syringes



2475
Articulating
Barrel
Syringe



2476
MI 1.8



2477
MI 1.8



2474
Cannula, only with
Luer-Connector
Suitable for syringes



2478



2479



2480



2481
Fig.1 ml
1.8EU



2485
Fig.1 MI
1.8 EU



2482
Water
point



2483
Wate
r
point



2484
Wate
r
point



Dental Tweezers



2486 ADSON
Curved
14cm

2487
ADSON
1x2/12c
m

2488
ADSO
N 12cm

2489
MICRO
ADSON 15cm

2490
Standard
14,18,25c
m

2491
Cushing
18cm

2492
Curved

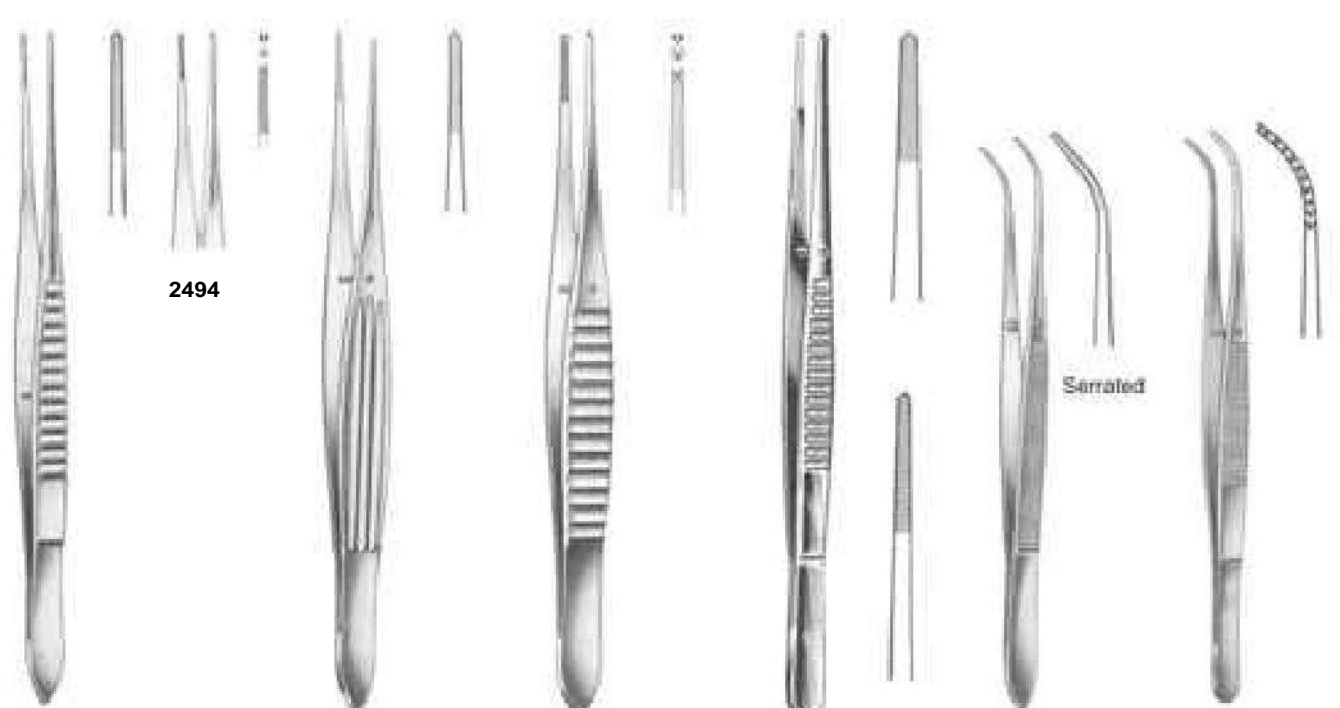

2493
SELECT
15,18,20c
m

2494

2495
MCINDO
E 15cm

2496
GILLIES
15cm

2497
WAUGH
15,20c
m

2498
PERRY
13cm

Serrated

2499
KOPP
15.5c
m



Dental Tweezers



2500
COLLEGE
15cm



smooth



2501
COLLEGE
15cm



serrated



2502
COLLEGE
15cm



smooth



2503
COLLEGE
15cm



serrated



2504
COLLEGE
15cm



smooth



2505
COLLEGE
15cm

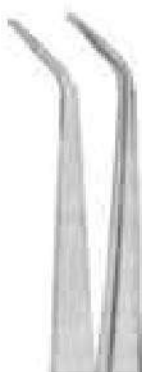

serrated



2506
COLLEGE
15cm



smooth



2507
COLLEGE
15cm



serrated



Dental Tweezers



2508
MERIA
M 16cm



smooth



2509
MERIA
M 16cm



serrated



2510
MERIA
M 16cm



smooth



2511
MERIA
M 16cm



serrated



2512
MERIA
M 16cm

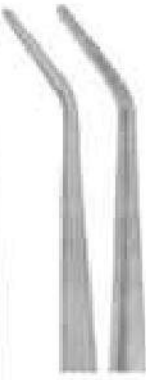

smooth



2513
MERIA
M 16cm

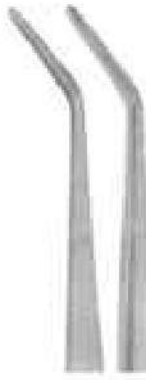

serrated



2514
MERIA
M 16cm



smooth



2515
MERIA
M 16cm



serrated



Dental Tweezers

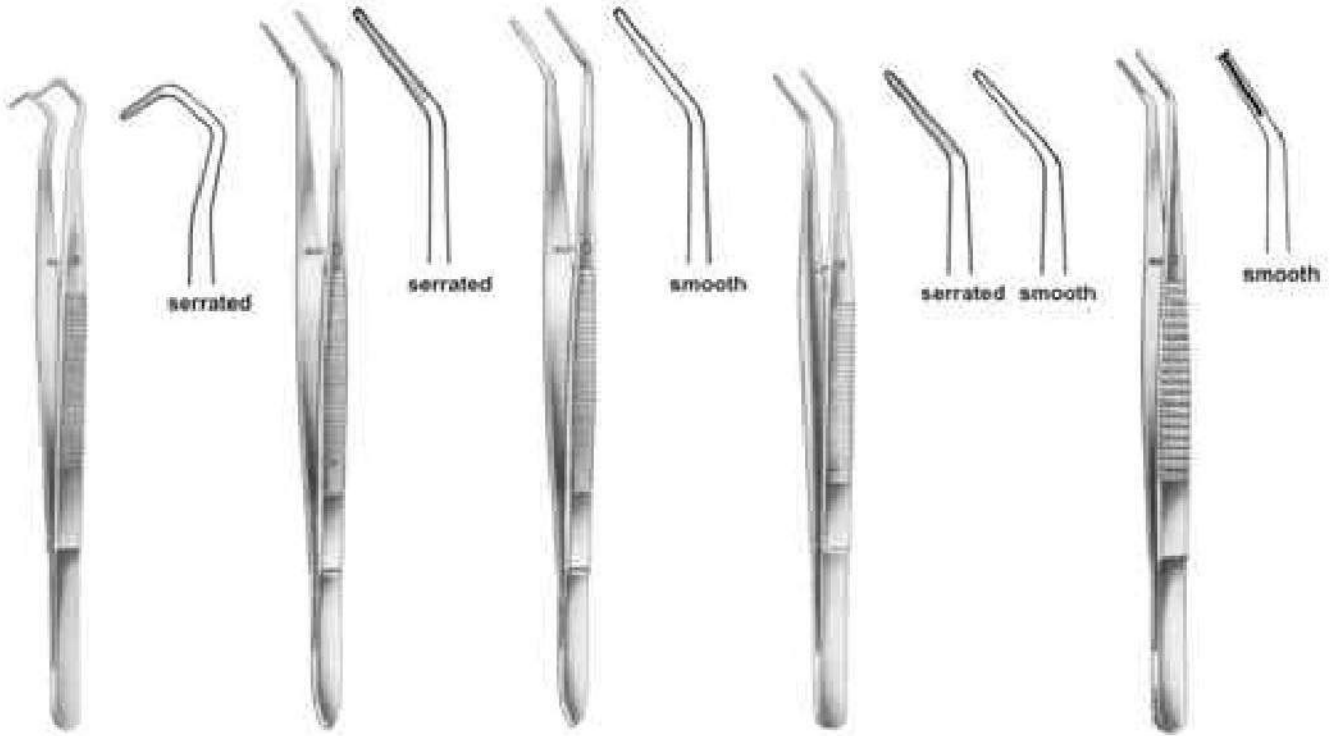

2516
COLLEGE
14.5cm

2517
FLAGG
16cm

2518
FLAGG
16cm

2519
LANDGRA
M 15cm

2520
15cm

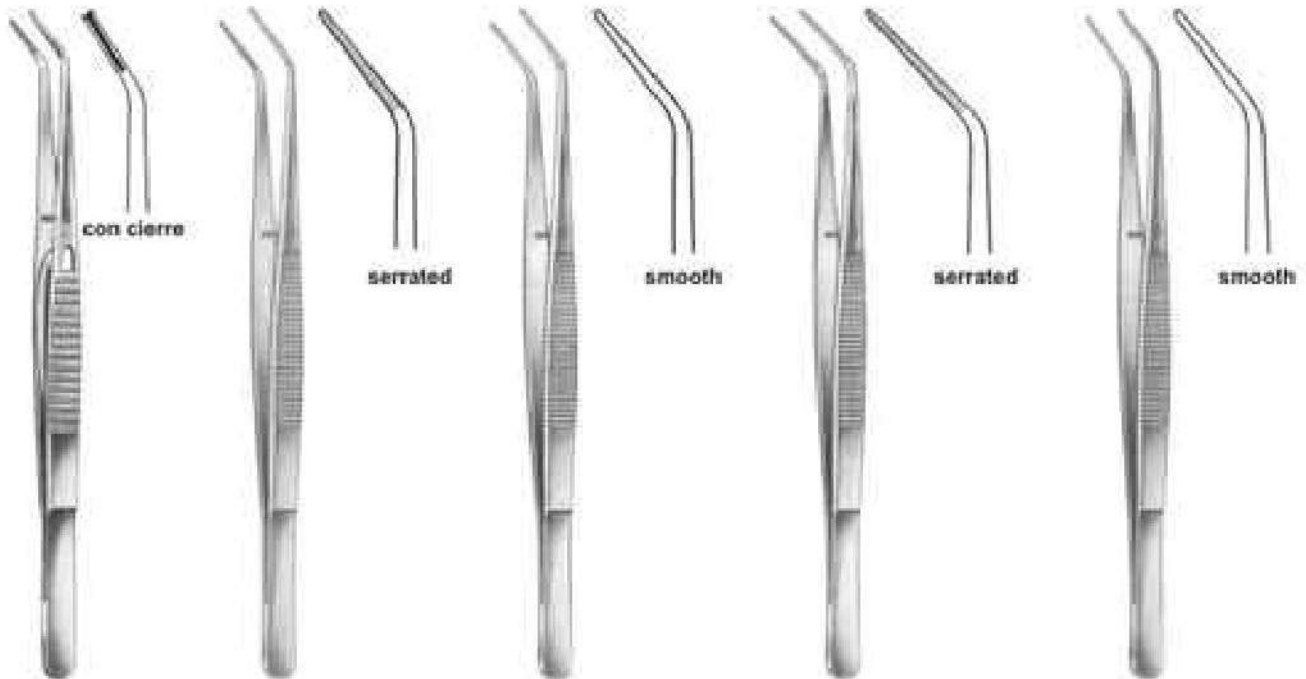

2521
15cm

2522 LONDON-
COLLEGE 15cm

2523 LONDON-
COLLEGE 15cm

2524 LONDON-
COLLEGE 15cm

2525 LONDON-
COLLEGE 15cm



Dental Tweezers

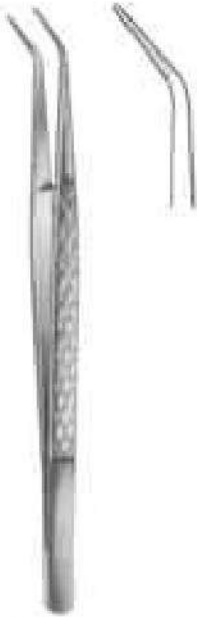

2526 LONDON-COLLEGE 15cm



2527 LONDON-COLLEGE 15cm



con cierre



2528 MERIA M 16cm



serrated



smooth

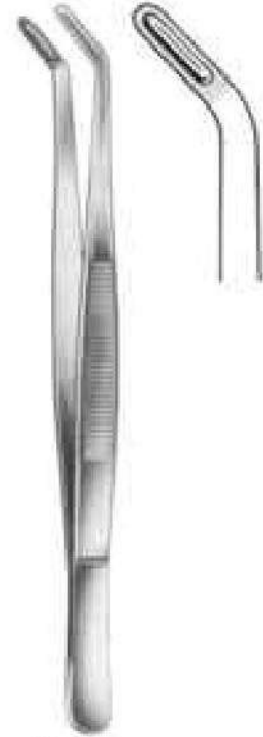

2529 ALLEN 18cm



2530 ALBRECH T 16cm



2531 ALBRECH T 16cm



2532 16cm



2533 16cm



2534 16cm





Strilizing & Lab Instruments



2535
DAVIS
6"



2536
GRASPING FORCEPS
6 1/4"



2537
**MESH BUR &
DIAMOND
HOLDER LARGE 2**
1/8" D



2538
Soldering
Tweezer 6 1/4"



2539
Narrow Fine
4 3/4"



2540
Super Fine
4 3/8"



2541
Fine Curved
4 1/2"



2542
Bonding Bracket
Holder 136mm



2543
Bonding Bracket
Holder 135mm



2544
Bonding Bracket
Holder 135mm



2545
Bonding Bracket
Holder 140mm

Section - 06

- * Endodontic Forceps
- * Tissue Forceps
- * Retractors
- * Mouth Gags

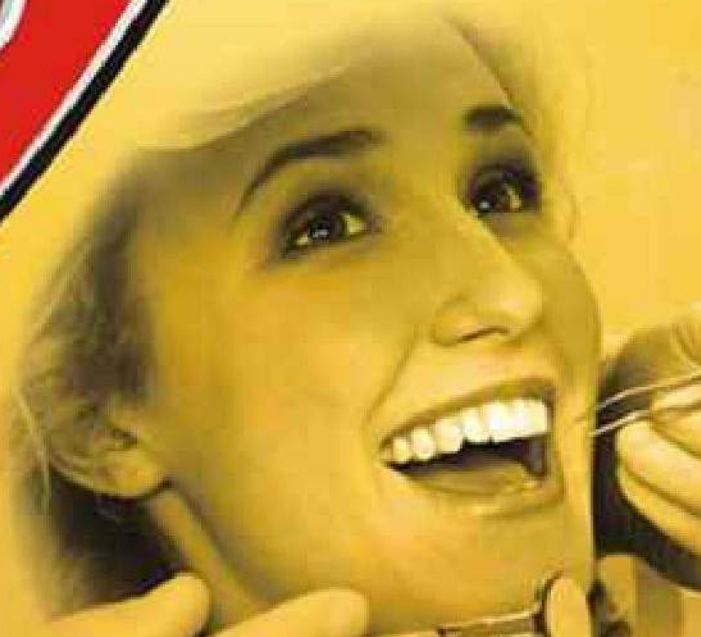
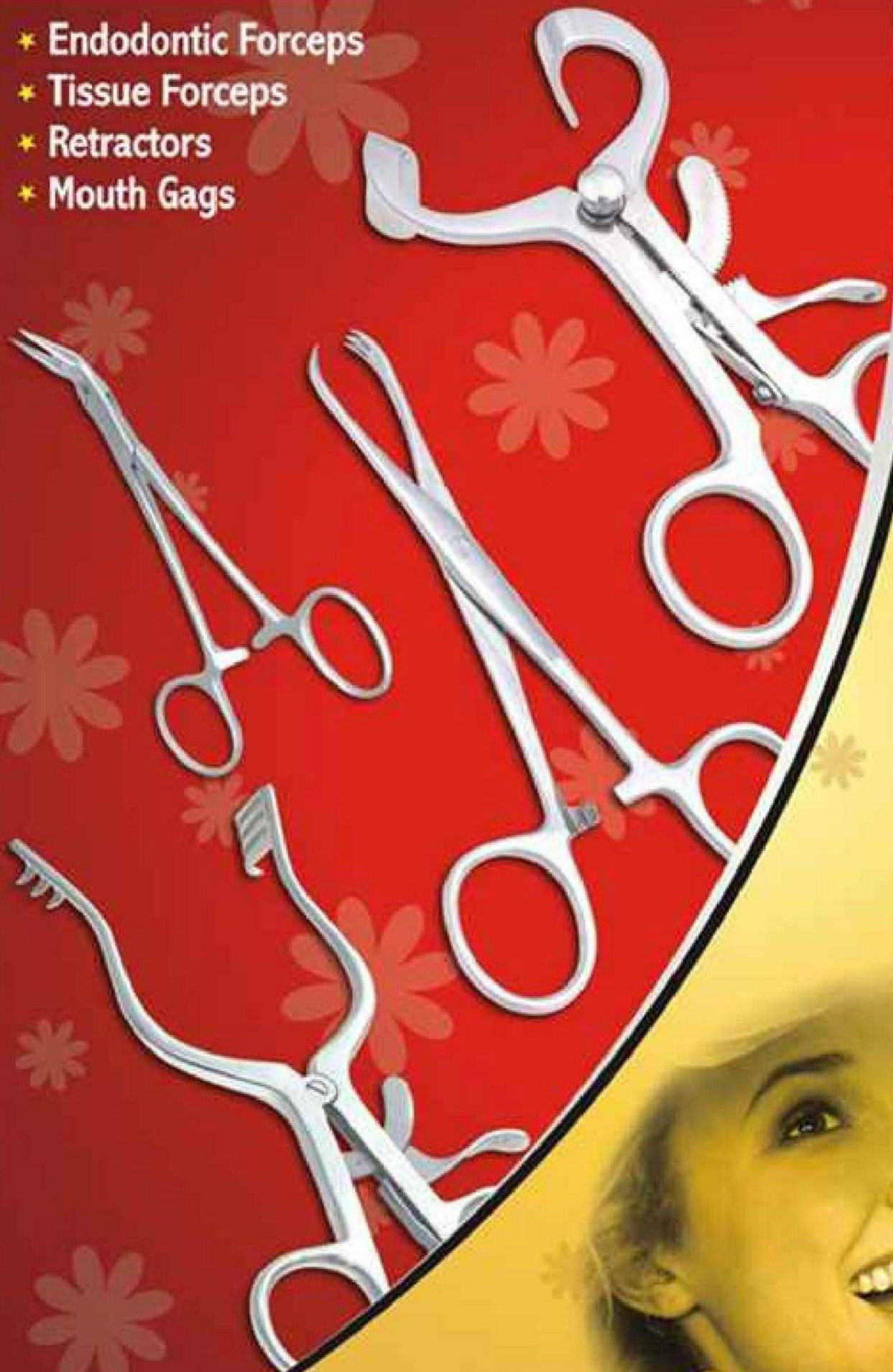



Endodontic Forceps



2546
Endo Forceps
4 3/4"



2547
PEETS Forceps
4 3/4"

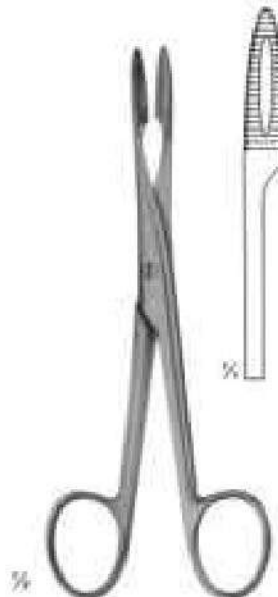

2548
Without Ratchet
145mm

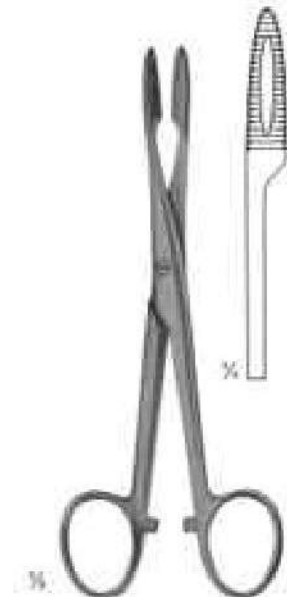

2549
With Ratchet
145mm



2550
CRILE
140m
m

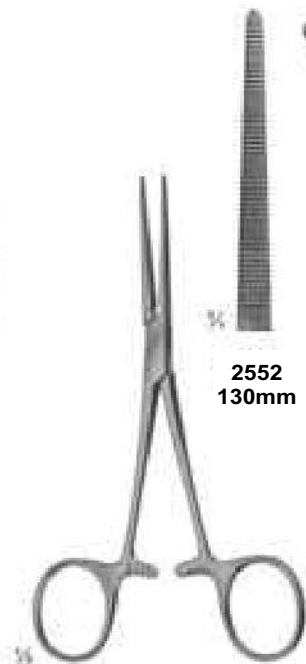

2551 PEAN
SLENDER TYPE

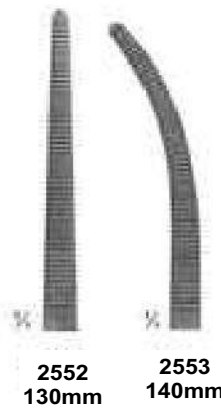

2552
130mm

2553
140mm

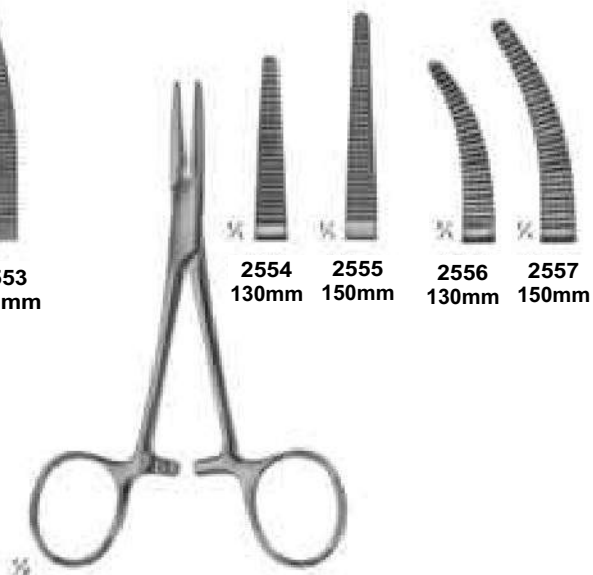

2554
SPENCER WELLS

2554
130mm

2555
150mm

2556
130mm

2557
150mm



Tissue Forceps



2558
BABY Allis
5" Straight
4x5 Teeth extra
delicates



2559 Allis
6" Straight
4x5 Teeth extra
delicates



2560 Allis
6" Straight
4x5 Teeth extra
delicates

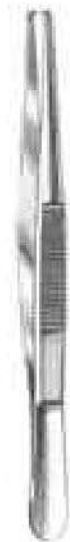

2561
1x2
Teeth 6"



2562
SEMKIN
1x2
Teeth 6"



2563
ADSON
1x2
Teeth 4
3/4"



2564
BROWN-
ADSON 7x7
Teeth
4 3/4"



2565
BROWN
8x8
Teeth 6"



2566
RUSSIAN
8x8
Teeth 6"



2567
EXTRA
Delicate
Straight 4"
1x2 Teeth



Hemostatic Forceps
Forceps
Towel Clamps, Napkin Holder



2568
HALSTED MOSQUITO
Straight. Curved 5"



2569
HALSTED MOSQUITO
Straight. Curved 5"
1x2 Teeth



2570
HALSTED MOSQUITO
Jaws 45 Angled on Flat 5"
Extra Delicate

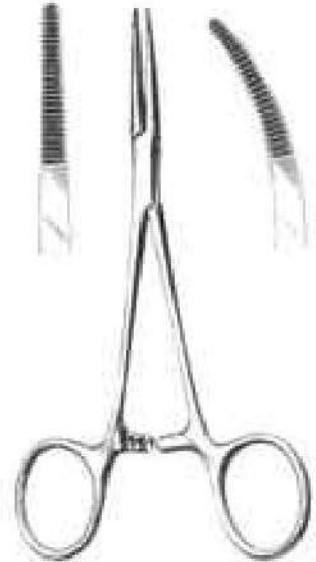

2571
KELLY
5 1/2" Straight



2572
JONE
S 3
1/2"

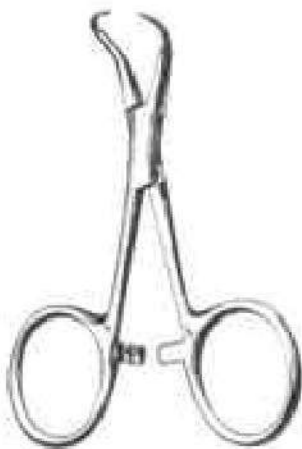

2573
BACKHUA
S 3 1/2"



2574
BACKHUA
S 5 1/4"



2575
LORNA
Non
Perforated 3
1/2"



Retractors, Depressors, Mouth Gags



2576
DENHARDT



2577
DENHARDT
MOUTH GAG with
Silicon Inserts
Interchangeable
Size: 125mm

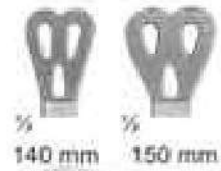

140 mm 150 mm



2578
WEIDER
Tongue depressor
2579 140mm
2580 150mm

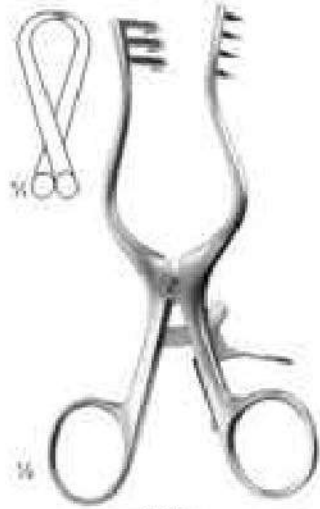

2583
WEITLANER
Sharp
130mm

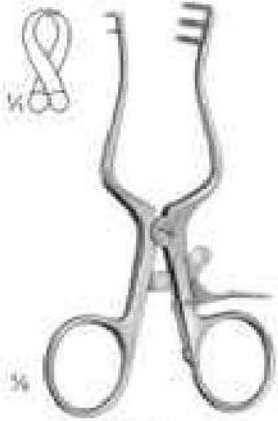

2584
WEITLANER
Sharp
110mm

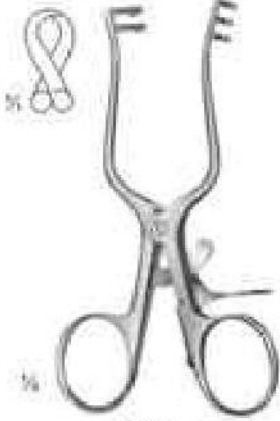

2585
WEITLANER
Semi Sharp
110mm



2581
TOBOLD
Tongue depressor
145mm



2582
ANDREW
Tongue depressor
110mm



2586
MOLT
Pediatric



2587
MOLT
Child



2588
MOLT
Adult



2589
FERGUSSON
ACKLAND Mouth Gag
Size: 145mm



2590
ROSER KOENIG
Mouth Gag
Size: 160mm/
185mm



Lip & Cheek Retractors

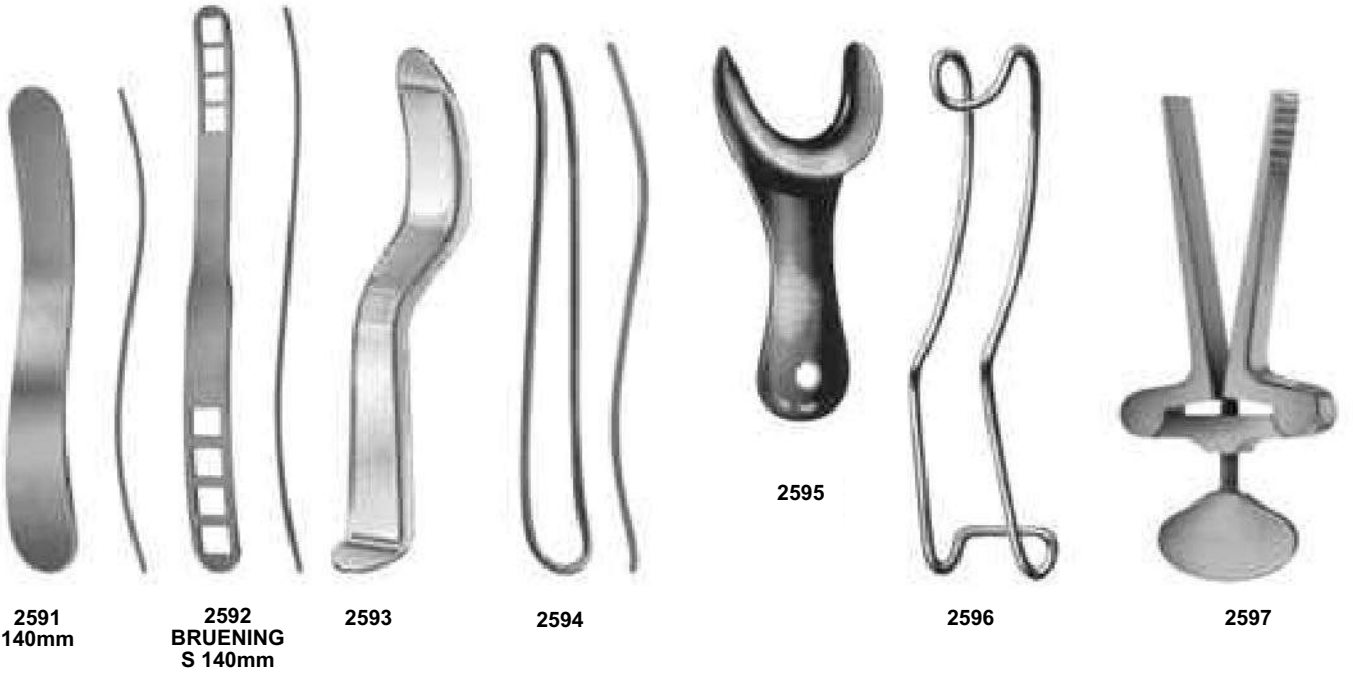

2591
140mm

2592
BRUENING
S 140mm

2593

2594

2595

2596

2597

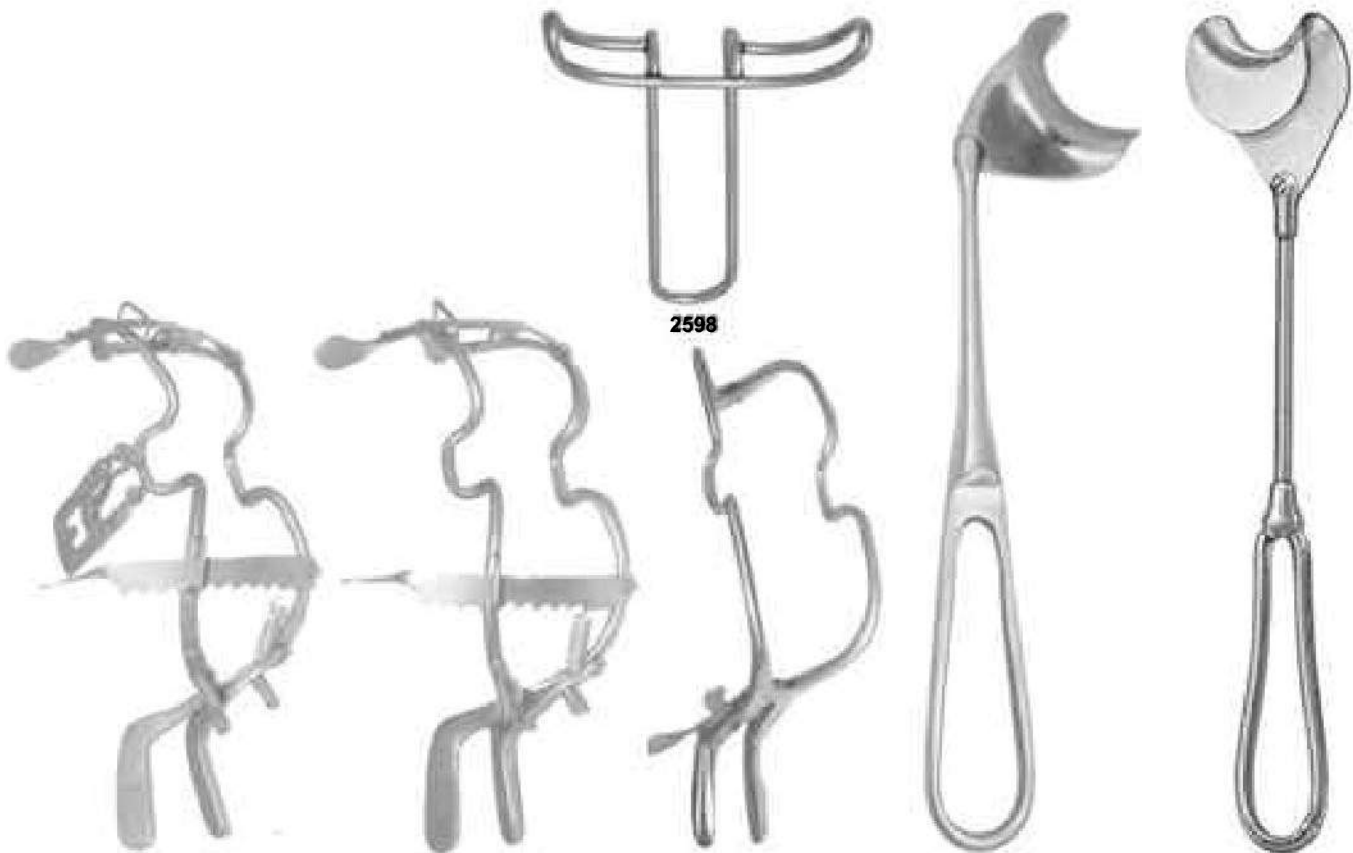

2598

2599
Mouth Gag with
Toungue
Deperessor 11.0 cm
13.0 cm
15.0 cm

2600
Mouth Gag with
Toungue Deperessor
11.0 cm
13.0 cm
15.0 cm

2601
Jennings, Mouth Gag
11.0 cm
13.0 cm
15.0 cm

2602

2603



Lip & Cheek Retractors

- 30 x 4 mm A
- 23 x 7 mm B
- 24 x 11 mm C
- 29 x 10 mm D
- 30 x 11 mm E
- 32 x 14 mm F
- 40 x 11 mm G
- 42 x 10 mm H
- 50 x 11 mm I
- 55 x 11 mm J
- 60 x 11 mm K
- 70 x 11 mm L
- 70 x 14 mm M



2604
LANGENBEC
K 210mm



2605
KOCHER
LANGENBECK 215mm



2606
BUCH
S
205mm



2607
KOCHE
R
230mm



2608
MIDDELDORPF



2609
15x15
Teeth
220mm



2610
29x22m
m
215mm

2611
28x28m
m
235mm



2612
KOCHE
R
230mm



2613
COLLIN
150mm



2614
ROUX
Set
165m
m



Sterilizing Forceps

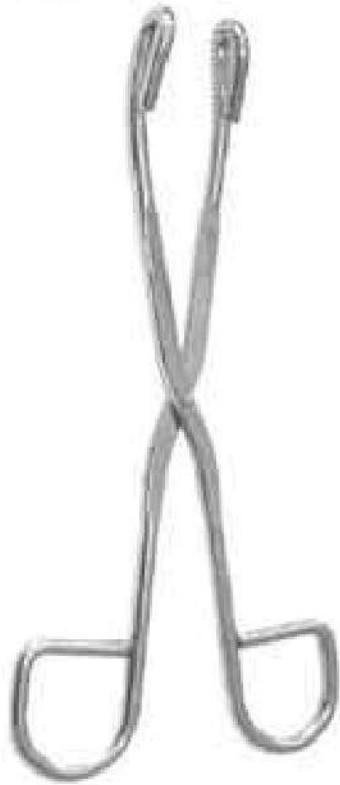

2615
Sterilizing Forcep Curved
20 cm A
25 cm B
30 cm C

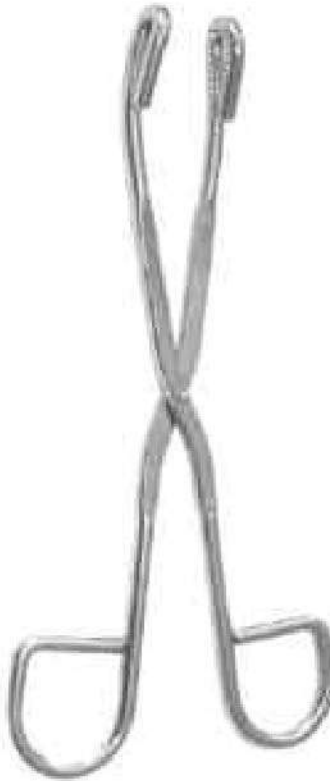

2616
Sterilizing Forcep Straight
20 cm A
25 cm B
30 cm C



2617
Sterilizing Forcep
30 cm



2618
Becht Tweezer



2619
Sterilizing Forcep
23 cm A
30 cm B

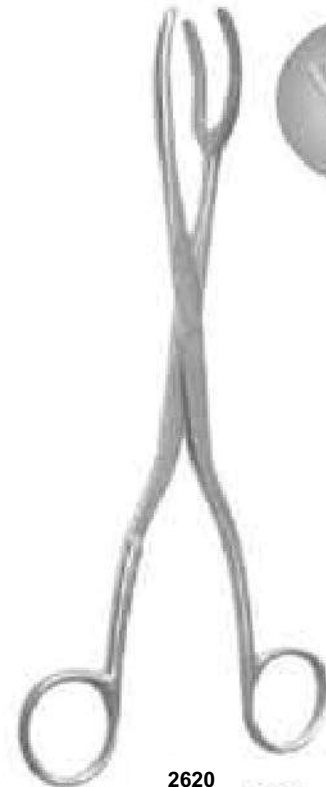

2620
Sterilizing Forcep
20 cm





Tissue Retractors & Hooks



2621
3 Sharp prongs



2622
2 Sharp prongs 6"



2623
2 Sharp prongs 6"



2624
FOMON
145mm



2625
ALM
70m
m



2626
SENN
3 Sharp Prongs
6 3/8"



2627 TOENNIS
Dura
Retractor
150mm



2628
JOSEP
H
165mm



2629
GILLIES
180mm

Section - 07

- * Orthodontic Pliers
- * Orthodontic Cutters
- * Rongeurs
- * Needle Holders





Orthodontic Pliers

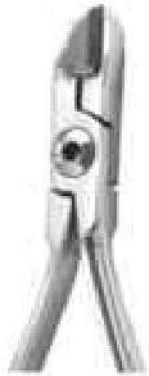

2630
Light Wire Cutter



2631
Wire Cutter



2632
Posterior Band
Remover Long



2633
Posterior Band Remover



2634
Jarabak Plier



2635
Distal End Cutter
Safety End
Cutter



2636
Distal End Cutter



2637
Kim's Plier



2638
Loop Forming Plier



2639
Tweed Arch Bending Plier



2640
Utility Plier



2641
Bonding Bracket Remover



2642
Lingual Arch Plier



2643
Light Wire Plier



2644
Wire
Cutter
12.5cm



Orthodontic Pliers

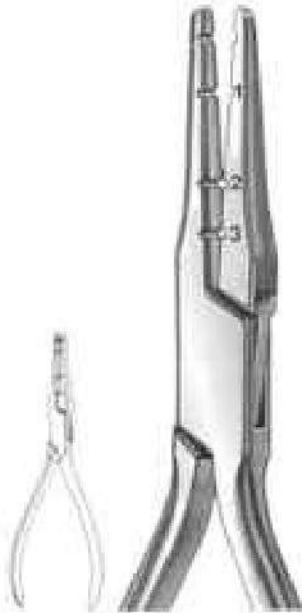

2645
Fig. 101
Wire Bending



2646
Fig. 118
PEESO
Collar



2647
Fig. 417
Crown Shell

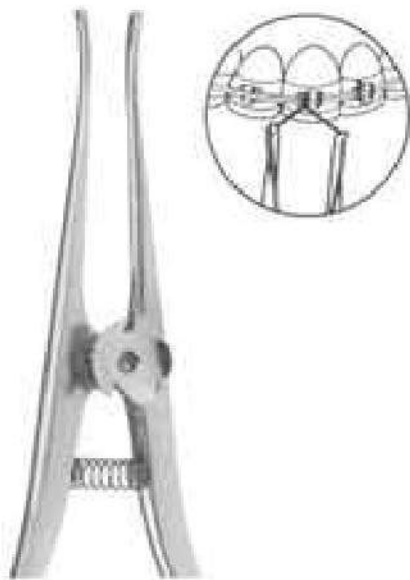

2645 STEINER
150 mm
Ligature Pliers

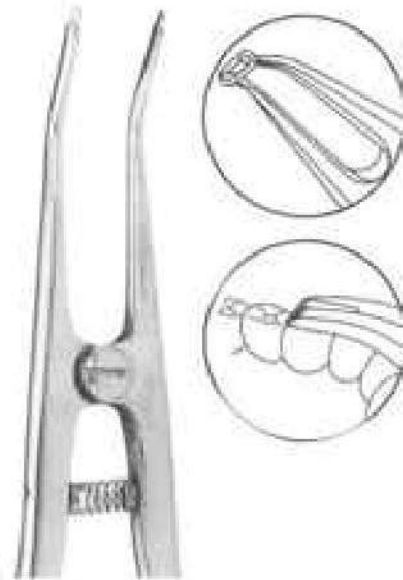

2649
Separating Pliers Elastics
150 mm



2650
121 lab & Of ce



Orthodontic Pliers

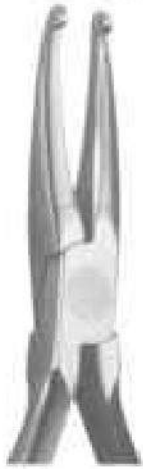

2651
How Plier Titanium Alloy
with special coated beaks



2652
How Plier
Tips are 3.2 mm
Diameter



2653
How Plier
Tips are 3.2 mm
Diameter

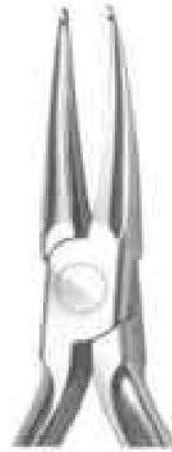

2654
How Plier Small
Tips are 3.2 mm
Diameter



2655
How Plier Offset
Tips are 3.2 mm
Diameter



2656
Weingart Utility Plier
Titanium Alloy
with special coated beaks



2657
Weingart Utility Plier
New type of the Weingart Utility Plier
designed for a more precise operation



2658
Weingart Utility Plier



2659
Weingart Utility Plier

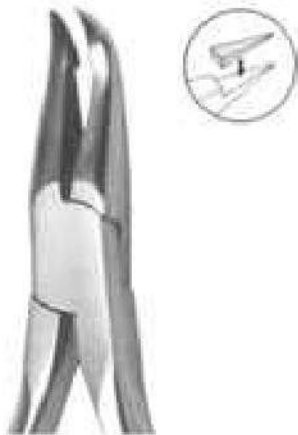

2660
Weingart Utility Plier



2661
Bird Beak Plier with Cutter
Maximum Banding &
Cutting Capacity
Wires up to .032°

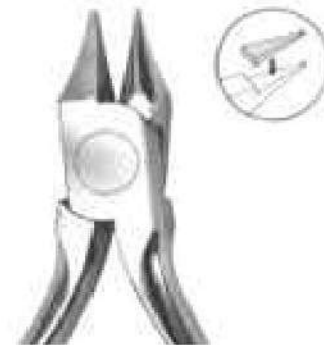

2662
Bird Beak Plier with Cutter
Maximum Banding Capacity
Wires up to .032°



2663
Bird Beak Plier with Cutter
Maximum Banding Capacity
Wires up to .030°



Orthodontic Pliers



2664
TWEED (Fig. 98)
13 cm
Tweed Loop Omega Pliers

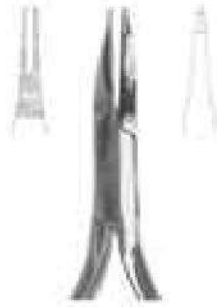

2665
TWEED (Fig. 90)
14 cm



2666
O'BRIEN (Fig. 97)
14 cm

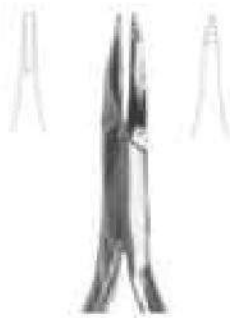

2667
TWEED (Fig. 96)
14 cm



2668
TWEED (Fig. 95)
13.5 cm

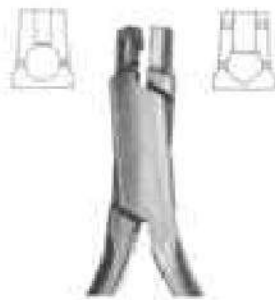

2669
SCHWARZ (Fig. 29)
12.5 cm

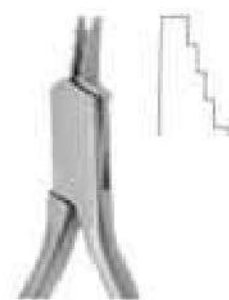

2670
NANCE (Fig. 80)
13 cm

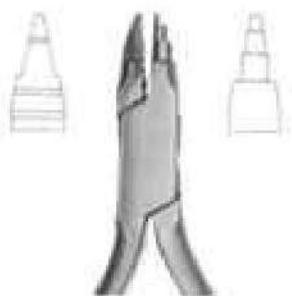

2671
YOUNG (Fig. 58)
13 cm



2672
SCHWARZ (Fig. 30)
13 cm

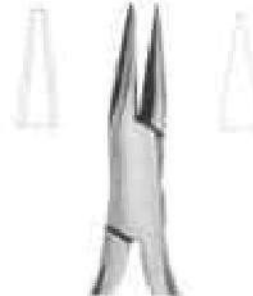

2673
Optical Plier (Fig. 53)
14 cm

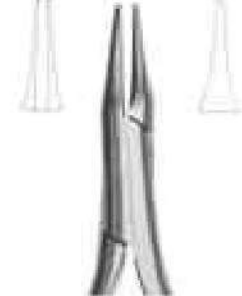

2674
Schwarz (Fig. 79)
13.5 cm



Orthodontic Pliers



2675
NANCE (Fig. 56)
12.5 cm
wire bending pliers



2676
JOHNSON (Fig. 59)
13.5 cm
Contouring plier

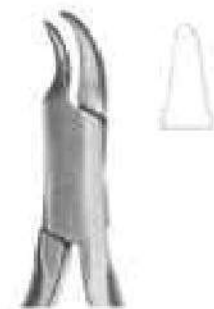

2677
REYNOLDS (Fig. 61)
13 cm
Contouring plier



2678
De La Rosa (Fig. 34)
12.5 cm
Contouring plier, Non Grooved



2679
De La Rosa (Fig. 35)
12.5 cm
Contouring plier, Grooved

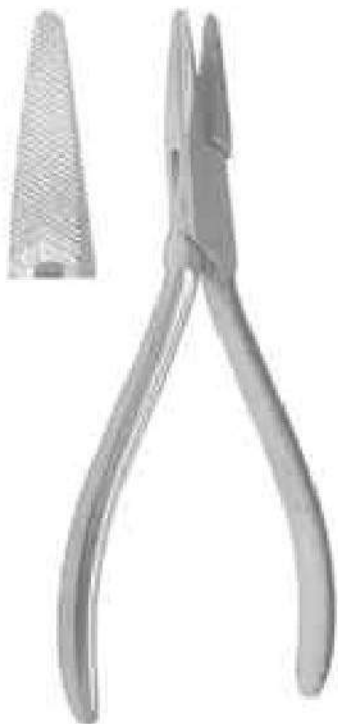

2680
14 cm
Goslee Contouring Plier

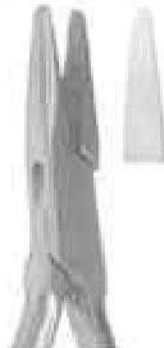

2681
14 cm
Goslee Contouring Plier



2682



2684
12.5 cm
Frevert Tweed (Fig. 51)
Tweed Arch Plier/ Standard Jaw

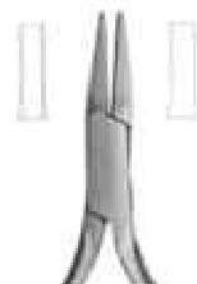

2685



2685
13 cm
ANGLE (Fig. 52)
Arch Forming Plier



Orthodontic Pliers



2687
Fig. 60
13 cm
Wire & Clasp Bending Pliers



2688
Fig. 60
13 cm
Wire & Clasp Bending Pliers

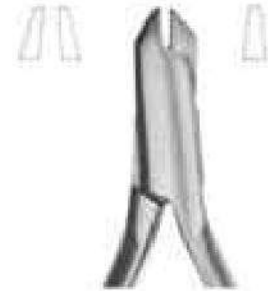

2689
Aderer (Fig. 57)
12 cm
Wire & Clasp Bending Pliers



2690
49 e 49 TC
14 cm
Band Removing Pliers Short Pad



2691
50 e 50 TC
14 cm
Band Removing Pliers Long Pad



2692
Fig. 84
14.5 cm
Band Pinshing & Ligature locking plier, serrated



2693
Fig. 72
14 cm
Band Pinshing & Ligature locking plier, serrated



2694
BRACKET (Fig. 82)
13.5 cm
Direct Bonding Bracket Remover



2695
BRACKET (Fig. 83)
13.5 cm
Direct Bonding Bracket Remover



Orthodontic Pliers

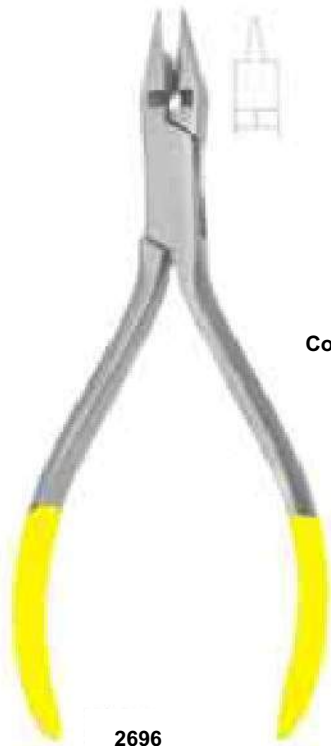

2696
38C, 38TC
13.5 cm
Contouring closing loop pliers
wire bending cutter

2697
40C, 40TC
13.5 cm

Contouring Pliers light wire pliers
grooved with cutter

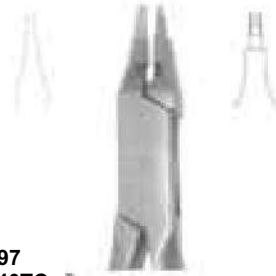

2698
Fig. 81
12.5 cm

Sling clasp & wire bending plier

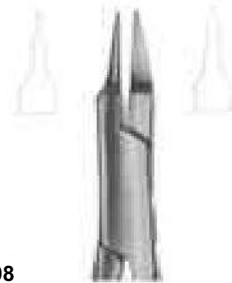

2699
Fig. 28
14 cm

Sling clasp & wire bending plier

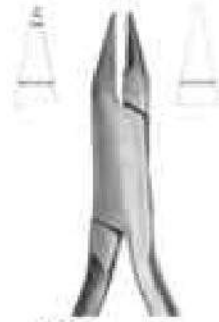

2700
Fig. 21
13 cm

Light wire bending pliers, grooved

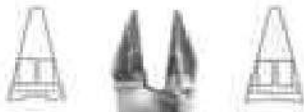

2701
ADAMS 23, 23TC
12.5 cm

Sling clasp & wire bending plier



2702
ADAMS (Fig. 33)
12.5 cm

For Retaining elements



2703
ADAMS (Fig. 44)
12.5 cm

Sling clasp & wire bending plier



2704
46C, 46TC
ADAMS -N 139c
12.5 cm
Bird beak with cutter



2705
Universal Wire Bending
Pliers (ADAMS) 47 TC, N 64
12.5 cm
Sling clasp & wire bending plier.



2706
86 C 86 TC
Angle Bird Beak - N 64
12.5 cm
Sling clasp & wire bending plier.



Orthodontic Cutters with T.C



Ø 1.0 mm
(0.40")

2707
Fig. 18 TC
15 cm



Ø 1.0 mm
(0.40")

2708
Fig. 92 TC
14 cm



Ø 0.4 mm
(0.16")

2709
Fig. 91 TC
13 cm



Ø 0.4 mm
(0.16")

2710
Fig. 99 TC
13 cm



Ø 0.4 mm
(0.16")

2711
Fig. 94 TC
13 cm
Angled at 15D with or
without spring on
the handles



2712
Fig. 85 TC
13 cm



2713
Fig. 87 TC
13 cm



2714
Fig. 85 TC
Angled at 15D
13 cm

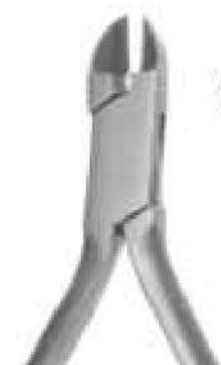

2715
ADAMS 87 TC
Angled at 15D
13 cm



Orthodontic Distal & Cutters



2716
Fig. 89 TC



2717
Fig. 64 TC
13 cm



2718
Fig. 67 TC
13 cm



2719
Fig. 88 TC
13 cm



2720
Fig. 77 TC
13 cm



Pliers For Orthodontic & Prosthetics



2721
UNIVERSAL
150 mm

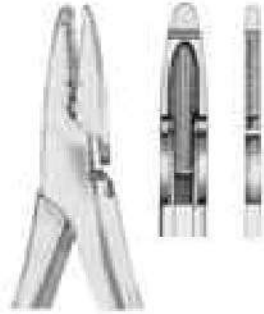

2722
WALDSACH
S 155 mm



2723
ADERE
R 125
mm



2724
NANCE
125
mm

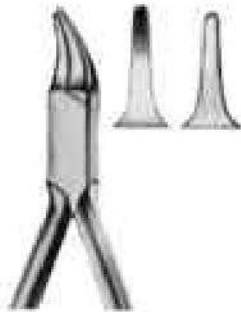

2725
REYNOLD
S 125 mm

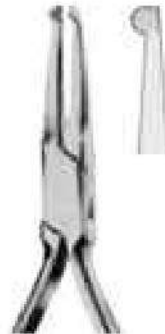

2726
HOW
145
mm



2727
HOW
140
mm



2731
FURRE
R 150
mm



2728
WALDRO
N 125 mm

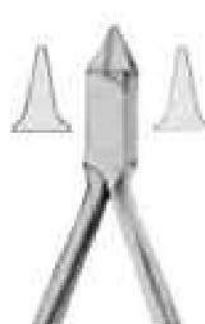

2729
ADAMS
125
mm

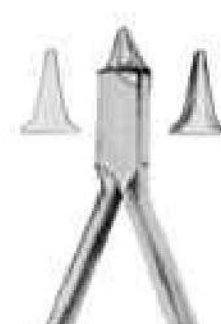

2730
ANGLE
125
mm

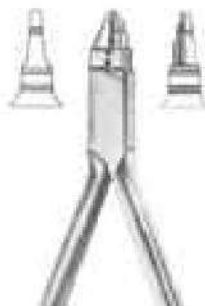

2732
YOUNG
130
mm

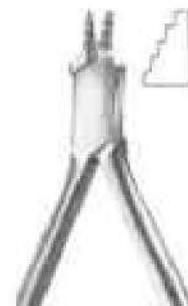

2733
NANCE
130 mm



Pliers For Orthodontic & Prosthetics

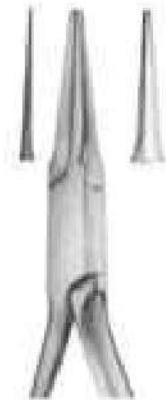

2734
LANGEBEC
H 125 mm



2735
LANGEBEC
H 140 mm

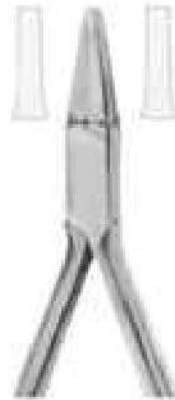

2736
LANGEBEC
H 130 mm

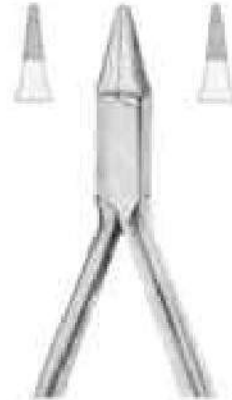

2737
PEESO
125
mm



2738
GOSLEE
125 mm

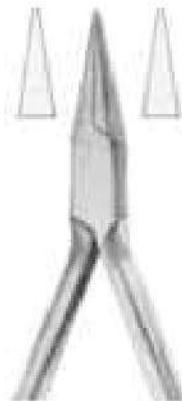

2739
FISCHE
R 140
mm



2740
FISCHE
R 140
mm

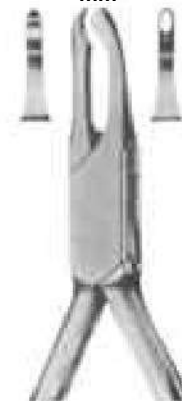

2741
JOHNSO
N 130 mm

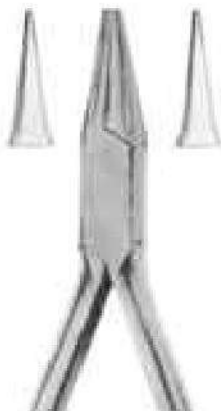

2742
MSY
130
mm



2743
MC KELLOPS
155 mm



2744
ANDRESE
N 130 mm



2745
SCHWAR
Z 130 mm



Rongeurs



2746
BLUMENTHAL
6", 30D
Standard



2747 MINI-
BLUMENTHAL 6",
45D



2748 MINI-
BLUMENTHAL 6",
90D

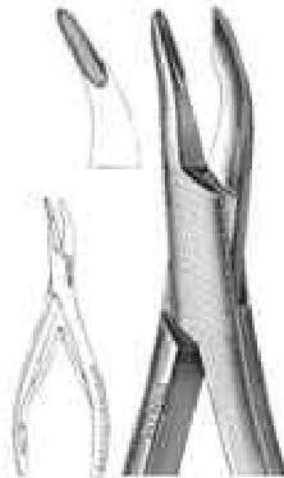

2749
BLUMENTHAL
7", 30D



2750 MINI-
BLUMENTHAL 4
1/2", 30D



2751 MINI-
BLUMENTHAL 4
1/2", 45D



Rongeurs



2752 CLEVELAND
No. 5-Side Cutting
6 3/4"

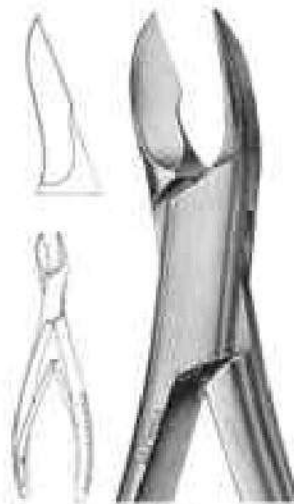

2753 CLEVELAND
No. 5A-Side Cutting
6 1/2"

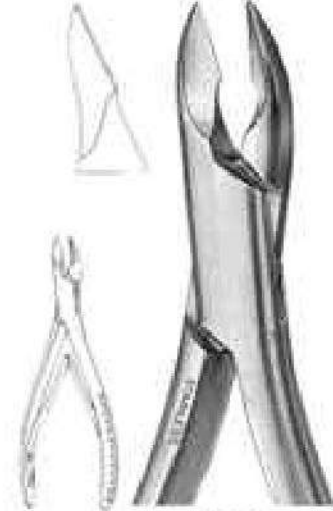

2754 CLEVELAND
No. 55 Side Cutting
6"



2755
NO. 1A-
MEAD 6 1/2"



2756
MEAD
Square No.
2A
6 1/2"

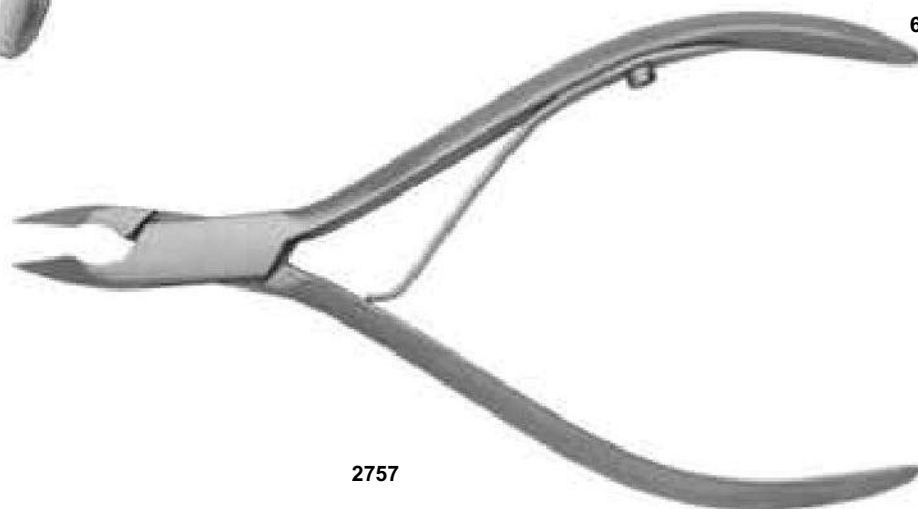

2757



Rongeurs



**2757
FRIEDMA
N 5 1/2"**



**2758 MICRO-FRIEDMAN
5 1/2" 15D Curved
Jaws**



**2759 MICRO-FRIEDMAN Perio
Rongeur 5 1/2"**



**2760
CLEVELAND
No. 4 5 1/2"**



**2761
CLEVELAND
No. 4A 6 1/2"**

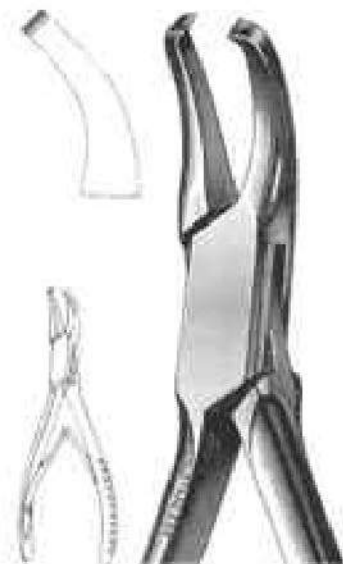

**2762 GARDNER
No. 6A, End Cutting
6 1/2"**



Rongeurs



**2763 BEYER
DOUBLE ACTION
16, 18 cm**



**2764
No.1
6
1/2"**

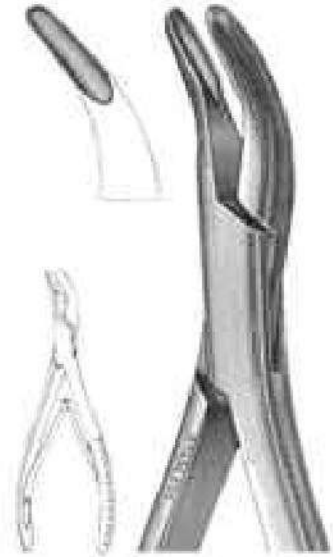

**2765
HARTMAN
5
3/4"
Strong
Curve**



**2766 BANE
Slight Curve
7"**



Needle Holders



2767 COLLIER
5" Fenestrated
Jaws

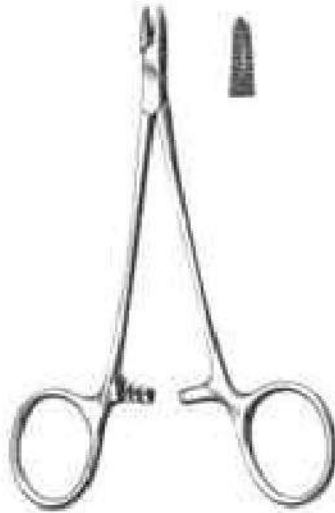

2768 DERF
4
3/4"

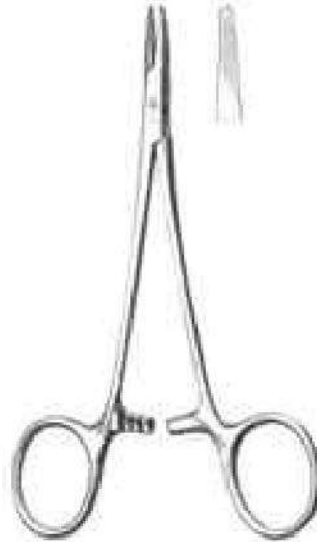

2769 WEBSTER
Delicate Smooth
Jaws 5"



2770 NEIVERT
One Offset Ring
5"



**2771 OLSEN-
HEGAR** 5 1/2"



2772 BAUMGARTNE
R 5 1/2"



**2773 CRILE-
WOOD** 6"



2774 GARDNE
R 5"



Needle Holders

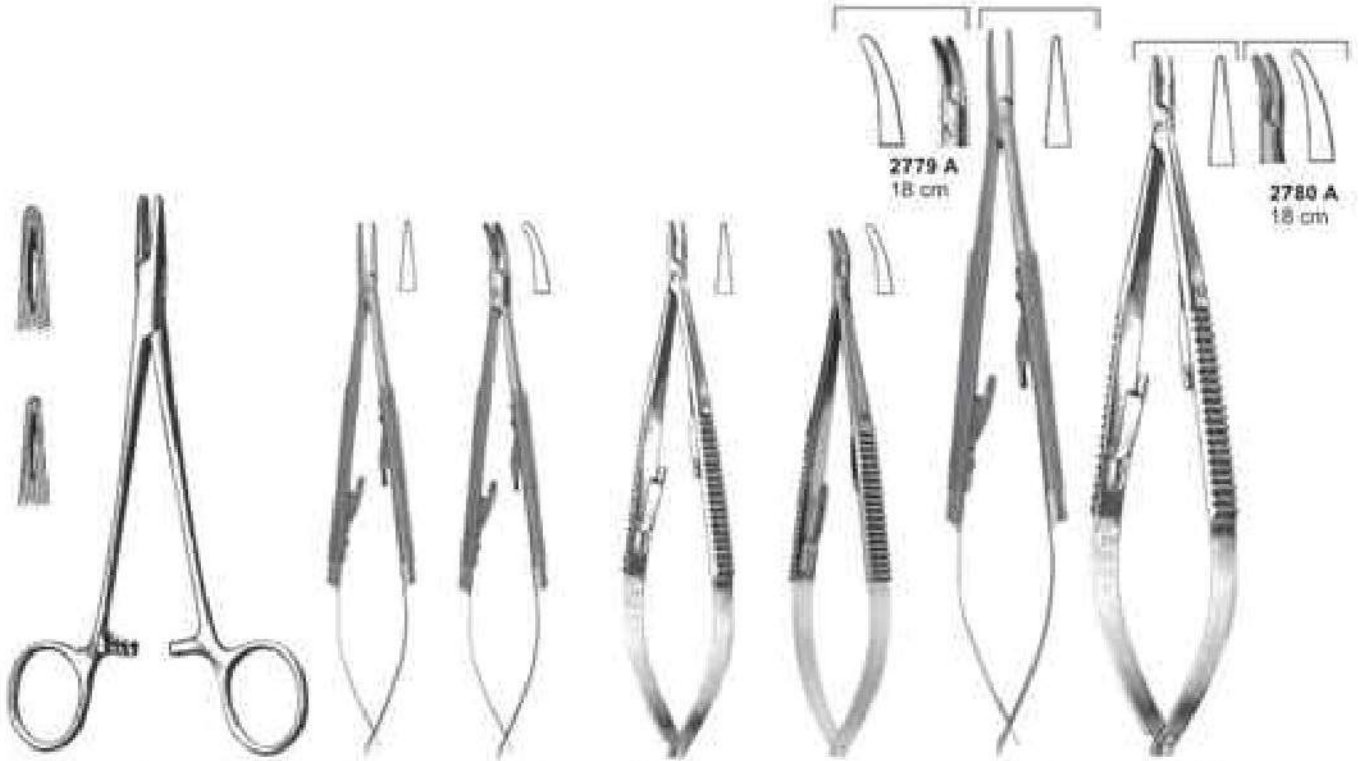

2775 MAYO-HEGAR 5"

2776 CASTTROVIEJO Smooth Jaws 14 cm"

2777 CASTTROVIEJO Smooth Jaws 14 cm"

2778 CASTTROVIEJO Smooth Jaws 14 cm"

2778A CASTTROVIEJO Smooth Jaws 14 cm"

2779 CASTTROVIEJO Smooth Jaws 18 cm"

2780 CASTTROVIEJO Smooth Jaws 18 cm"



2781 BOYNTON 5"



2782 CRILE 6"



2783 MATHIEU 5 1/2"



2784 STEVENS 6 1/2"



Micro Surgery Set



2785
Micro Scissor
Straight
155mm



2786
Micro Scissor
Straight
150mm



2787
Micro Scissor
Curved
150mm



2788
Micro Scissor
Curved
155mm

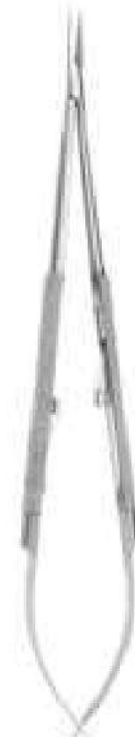

2789
CASTROVIEJO
T.C
Straight
180mm



2790
Retractor
r Fig. 3
165 mm



2791
Micro Adson
120 mm



2792
GERAL
D
Curved
180 mm



2793
GERAL
D
Straight
175 mm



2794
Micro Adson
160 mm



2795
Micro Surgery Set 10 pcs

Section - 08

- * Scissors
- * Impression Trays
- * Articulators
- * Hollow Wares
- * T.C. Instruments

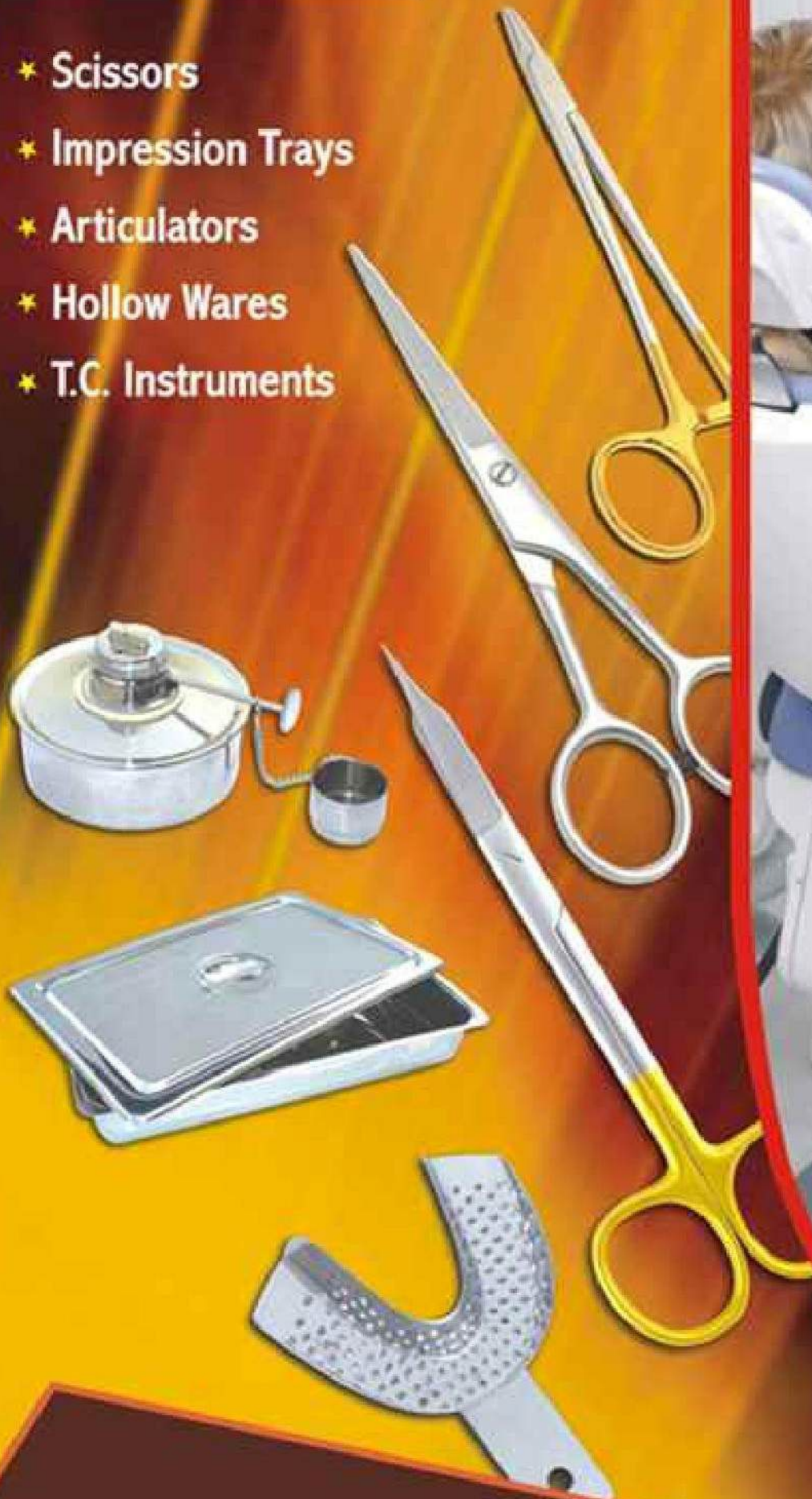



Scissors



2796
IRIS (Standard)
Straight
11.5 cm

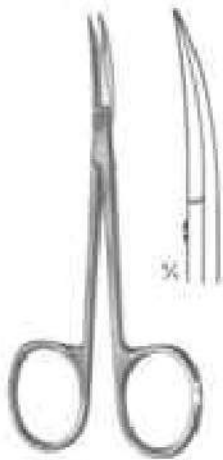

2797
IRIS (Standard)
Curved
11.5 cm

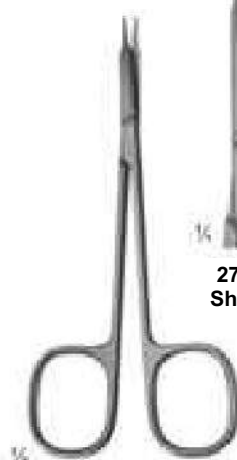

2798 STEVENS
Dissecting
Scissors Size: 11.5
cm

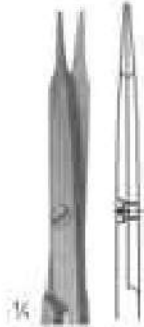

2799
Sharp



2800
Sharp



2801
Blunt



2802
Blunt



2803



2804
JOSEPH
Size: 150
mm

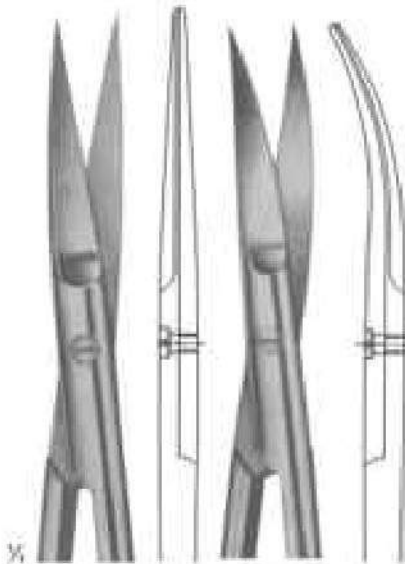

2805

2806

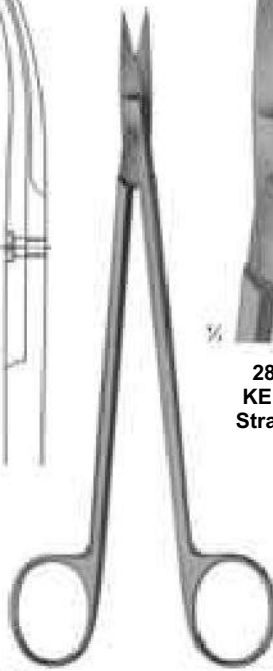

2807 KELLY
Size: 175
mm

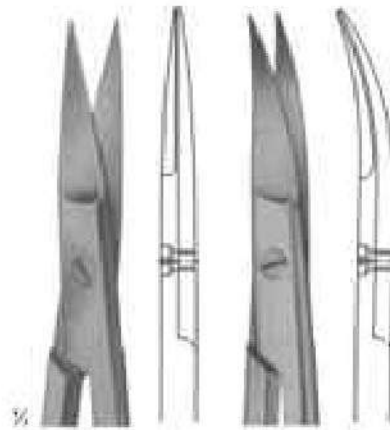

2808
KELLY
Straight

2809
KELLY
Curve
d



2810
QUINBY
Size:
130mm



Scissors

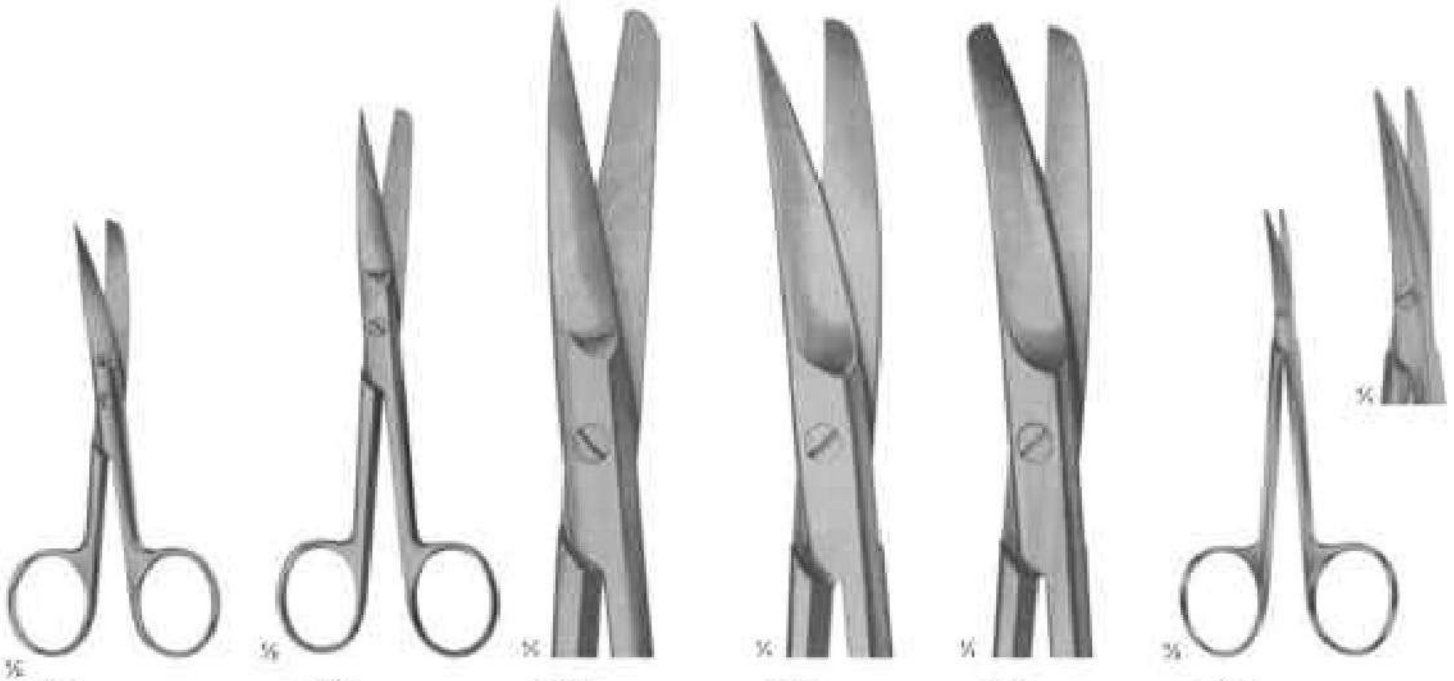

2811
Standard -
Types Size: 115
mm

2812
DEAVER
with at lock

2813
Size: 145 mm

2814
Size: 145 mm

2815
Size: 145 mm

2816 LITTLER
DISSECTING SCISSORS
Size: 115 mm

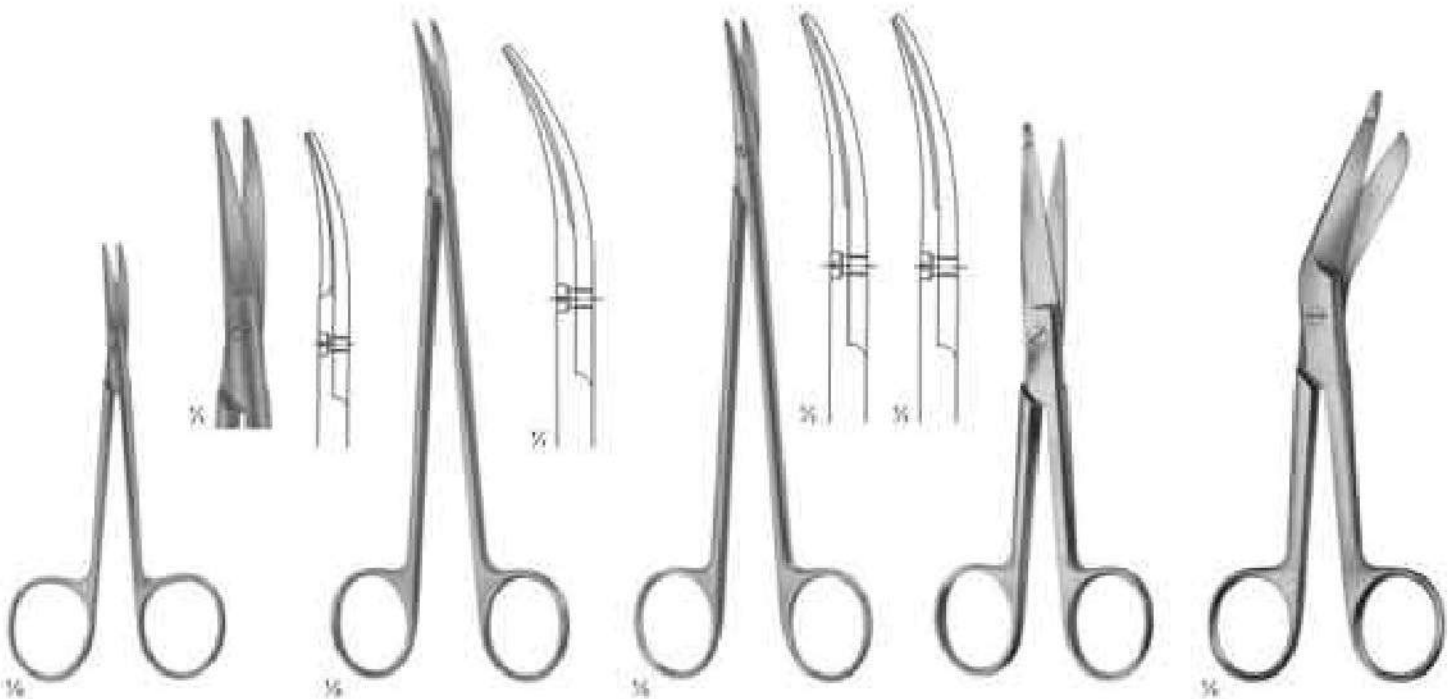

2817 COTTLE
Building scissors
Size: 115 mm

2818 DE-BAKEY
Ateriotomy
scissors Size: 175
mm

2819
TOENNIS -
ADSON
Dissecting issors
Size: 175 mm

2820
KNOWLES
Size: 145
mm

2821
Lister



Scissors

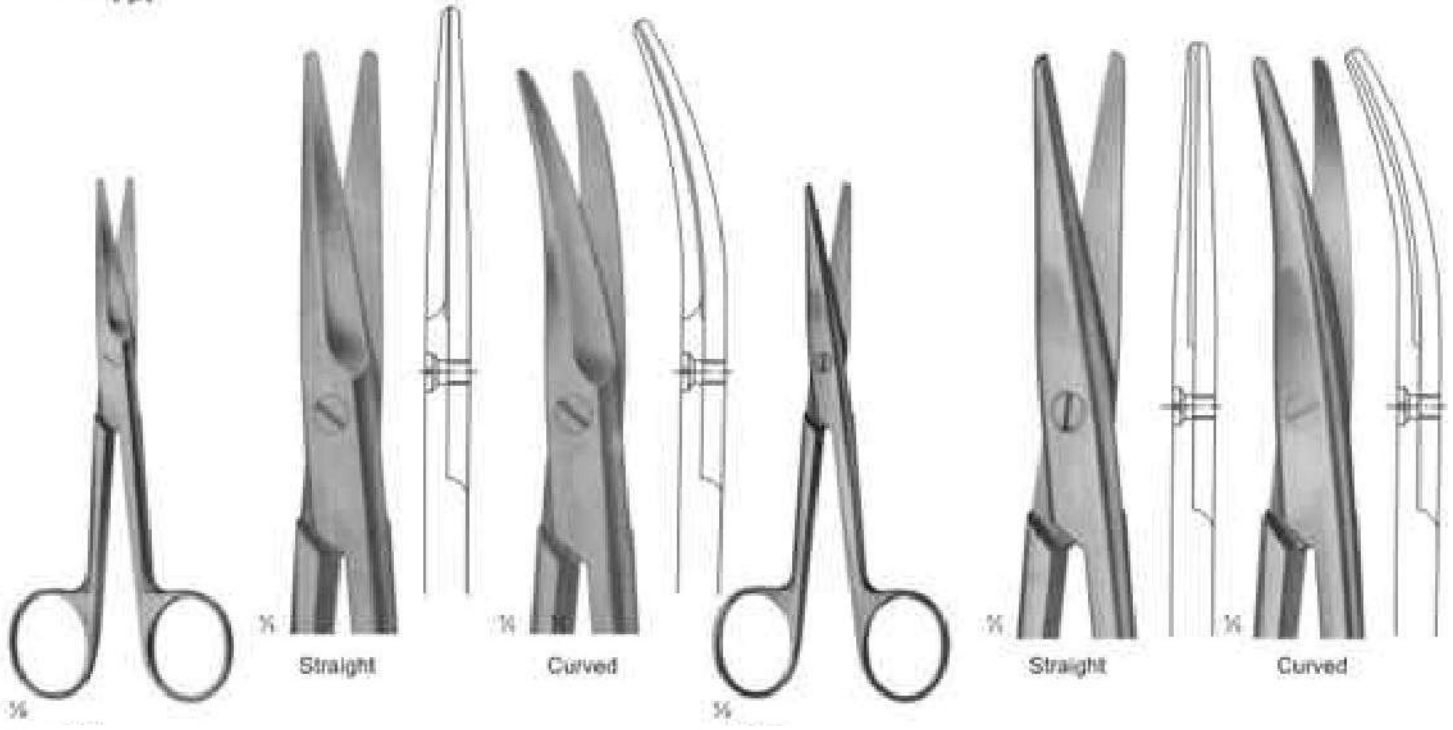

2822
MAYO (straight)
Size: 140 mm

2823
MAYO-STILLE (straight)
Size: 140 mm



2824 STILLE
Size: 140 mm

2825
METZENBAU
M Size: 145

2826 NELSON-
METZENBAUM Size: 230mm



Scissors



2827 DE BAKEY
Size: 155mm

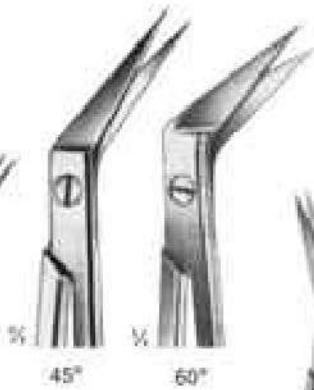

2828 LOCKLIN
Curved |
sideways
1 Toothed
Blade Size: 155 mm



2829 LaGrange
Double Curved
11.5 cm



2830 Goldman-Fox
Double Curved
13 cm



2831 SPENCER
Size: 90 mm



2832 LITTAUER
Size: 135 mm

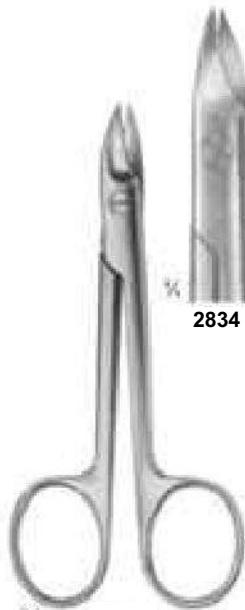

2833 DEEBEE
Size: 110mm

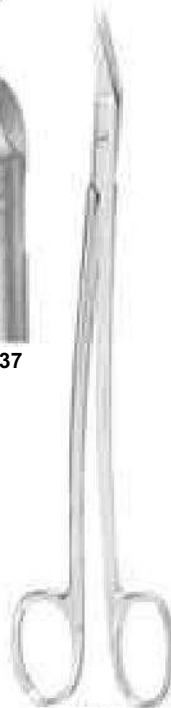
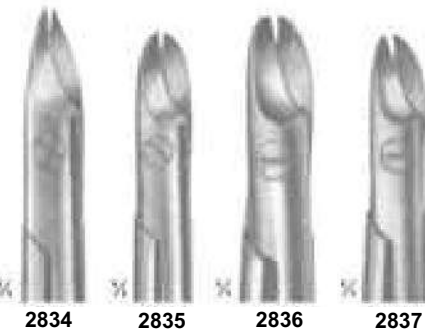

2838 Dean
17c

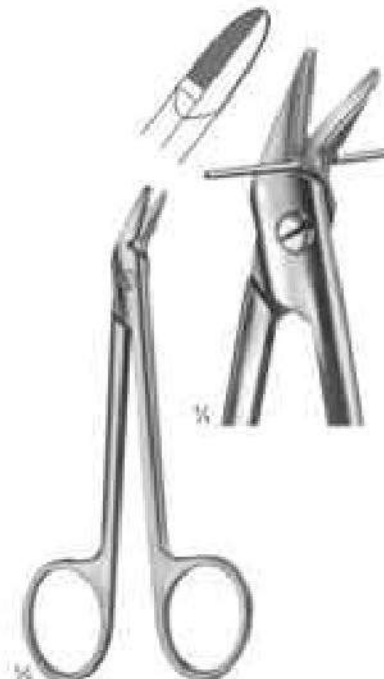

2839
1 Blade
Serrated
Size: 120mm

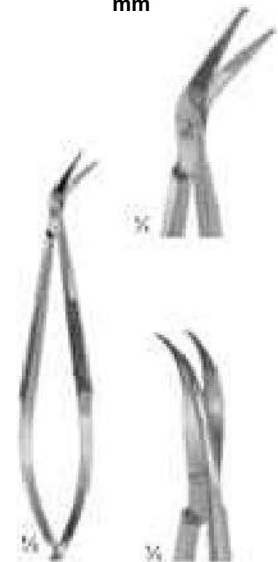

2840 CASTROVIEJO
Size: 90mm



Impression Trays

Made of 18/8 Stainless Steel, Solid, Set of 10



2841
U1



2842
U2



2843
U3



2844
U4



2845
U5



2846
L1



2847
L2



2848
L3



2849
L4



2850
L5

All The Above Impression Trays are Available in These 5 Sizes

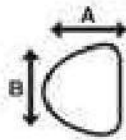

UPPER	U1	U2	U3	U4	U5
	A	62	60	53	54
B	83	75	73	69	68

All Dimension are in mm

LOWER	L1	L2	L3	L4	L5
	A	63	61	57	60
B	82	81	78	74	71

All Dimension are in mm



Perforated, Set of 10



2851
U1



2852
U2



2853
U3



2854
U4

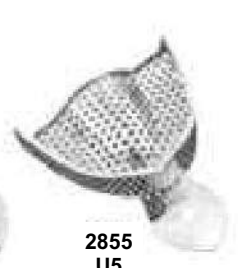

2855
U5



2856
L1



2857
L2



2858
L3



2859
L4



2860
L5



Impression Trays

Made of 18/8 Stainless Steel, Solid Full Denture Set of 8

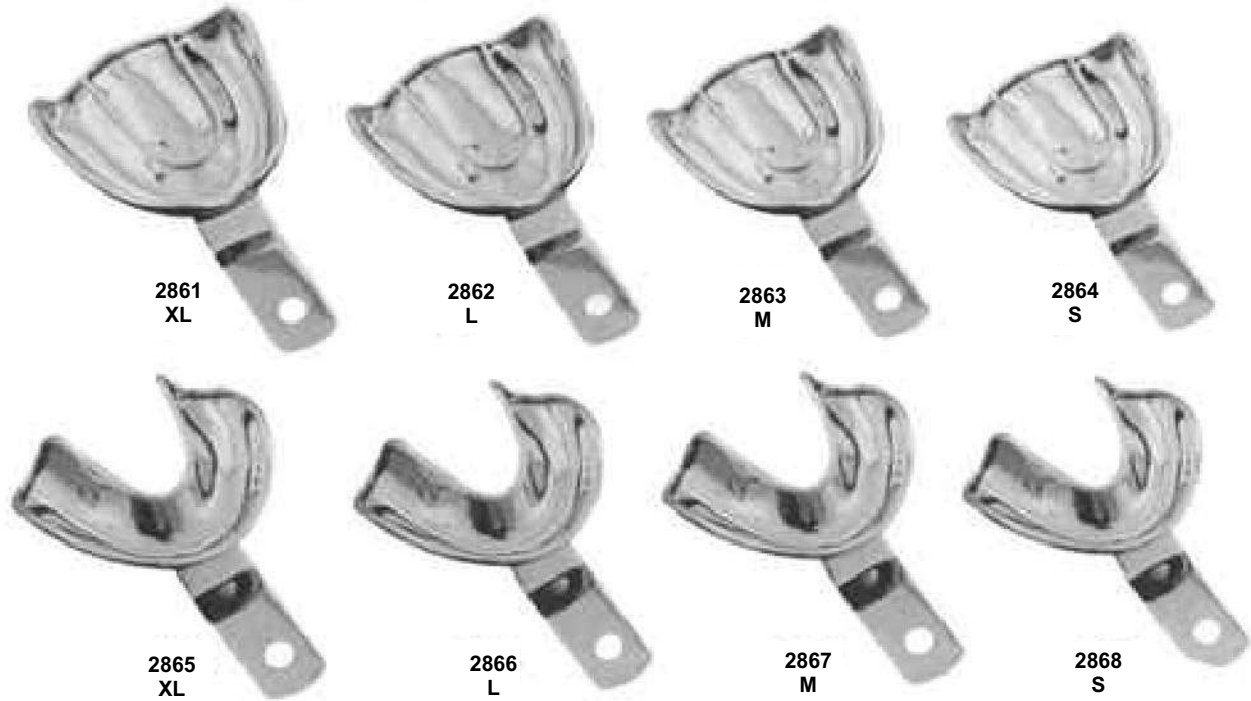

All The Above Impression Trays are Available in These 4 Sizes

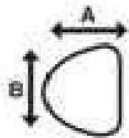

UPPER		XL	L	M	S
	A	70	67	64	60
B	79	76	70	73	

All Dimension are in mm

LOWER		XL	L	M	S
	A	64	64	60	57
B	86	70	73	70	

All Dimension are in mm

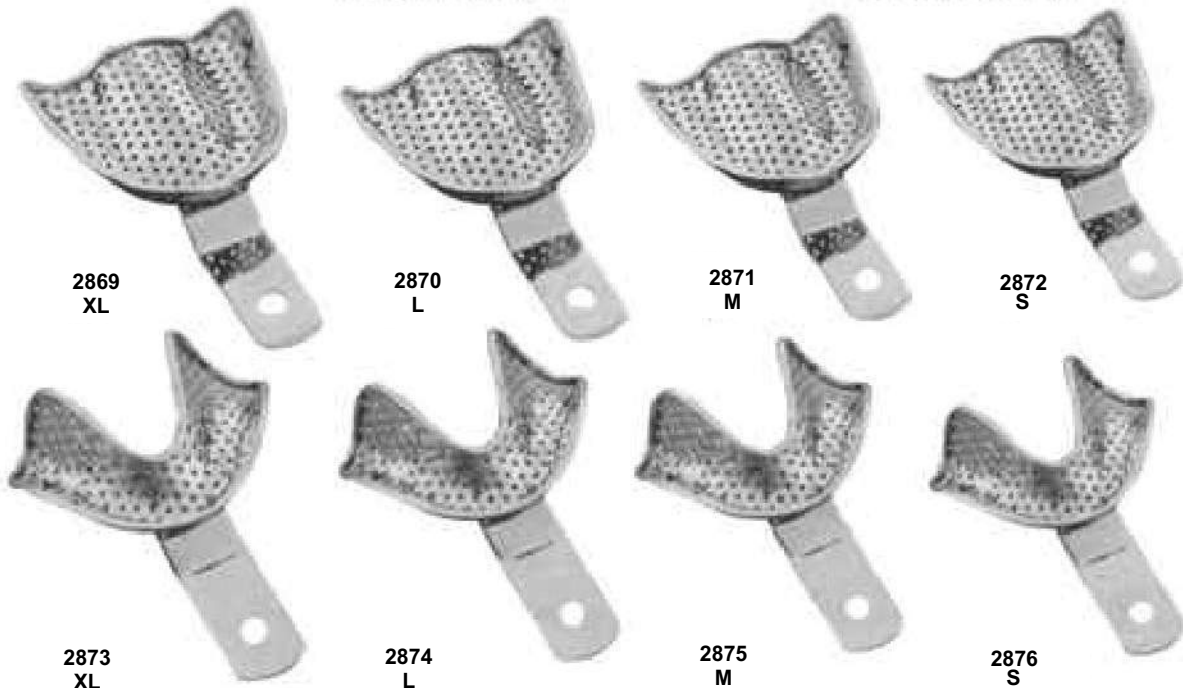

Perforated Full Denture Set of 8



Impression Trays

Made of 18/8 Stainless Steel, Solid Set of 6



2877
U1



2878
U2



2879
U3



2880
L1



2881
L2



2882
L3

All The Above Impression Trays are Available in These 4 Sizes

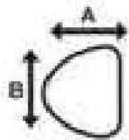

UPPER		U1	U2	U3
	A	67	64	57
B	81	71	70	

All Dimension are in mm

LOWER		L1	L2	L3
	A	60	57	54
B	81	79	76	

All Dimension are in mm



2883
U1



2884
U2

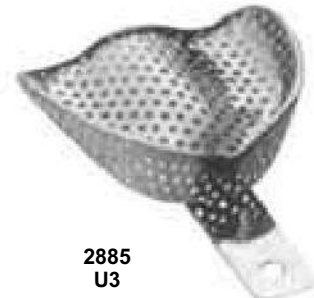

2885
U3



2886
L1



2887
L2



2888
L3

Perforated Set of 6



Impression Trays

Made of 18/8 Stainless Steel, English Pattern Set of 8

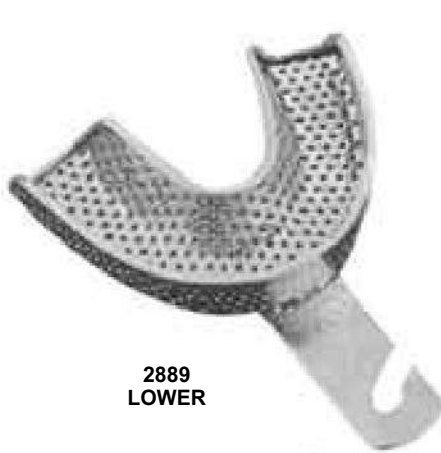

2889
LOWER



2890
UPPER

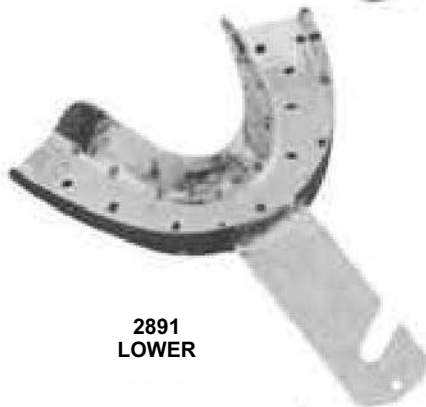

2891
LOWER



2892
UPPER



2893
LOWER



2894
UPPER

All The Above Impression Trays are Available in These 4 Sizes

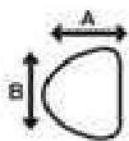

UPPER	Size	A	B	C
	0	67	50	12
	1	72	51	13
	2	78	55	15
	3	80	58	15

All Dimension are in mm



LOWER	Size	A	B	C
	0	70	50	14
	1	77	51	15
	2	79	55	15
	3	80	60	17

All Dimension are in mm



Impression Trays

Made of 18/8 Stainless Steel, Solid Full Denture Set of 8

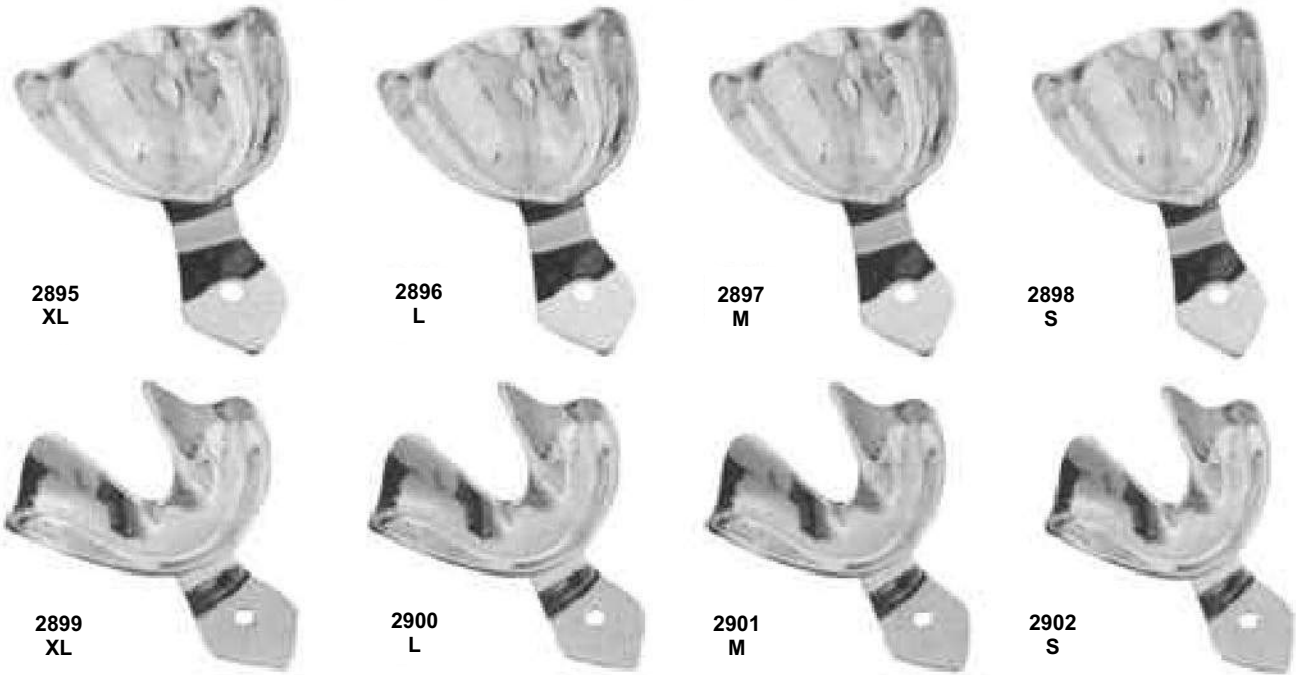

All The Above Impression Trays are Available in These 4 Sizes

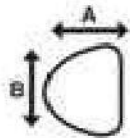

UPPER		XL	L	M	S
	A	70	67	64	60
B	79	76	70	73	

All Dimension are in mm

LOWER		XL	L	M	S
	A	64	64	60	57
B	86	70	73	70	

All Dimension are in mm

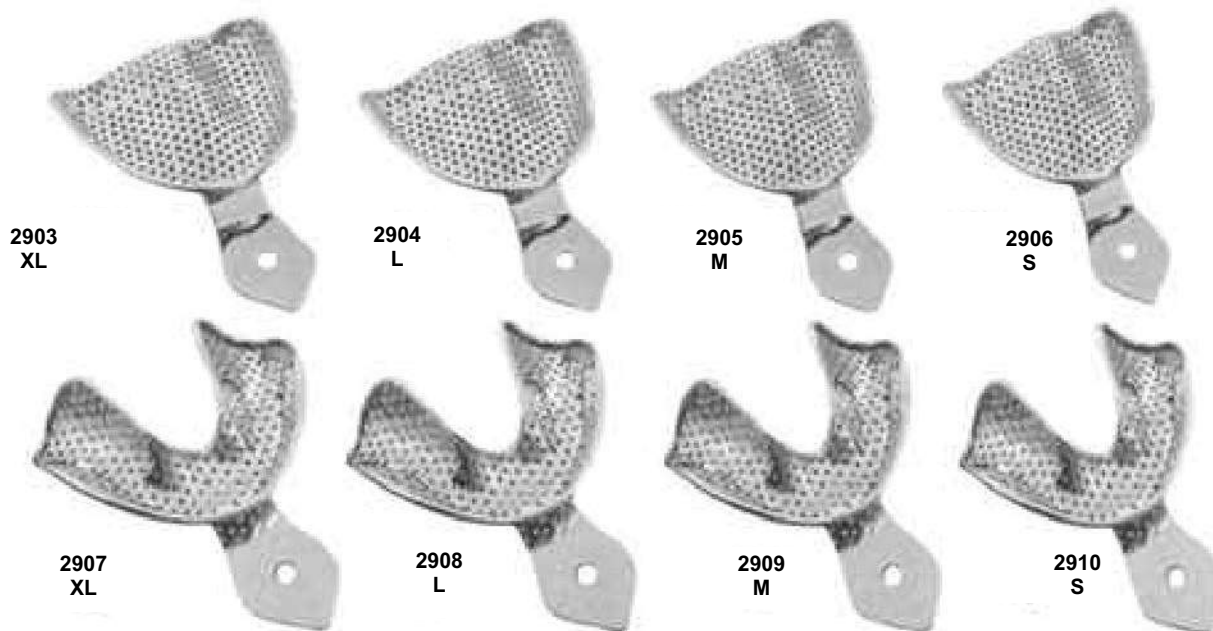

Made of 18/8 Stainless Steel, Perforated Full Denture Set of 8



Impression Trays

Made of 18/8 Stainless Steel, Solid Full Denture Set of 8



2911
U0



2912
U1



2913
U2



2914
U3



2915
L0



2916
L1



2917
L2



2918
L3

Upper Sizes: 0,1,2,3

Depth of Tray: 15,9 mm, Height of Plate: 12,5 mm

Lower Sizes: 0,1,2,3

Depth of Tray: 12,9 mm

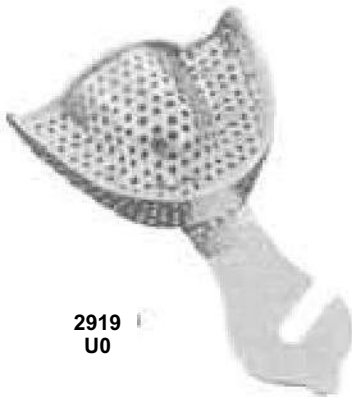

2919
U0

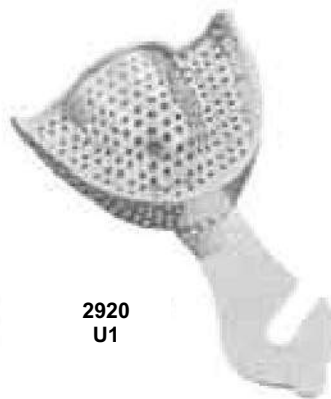

2920
U1

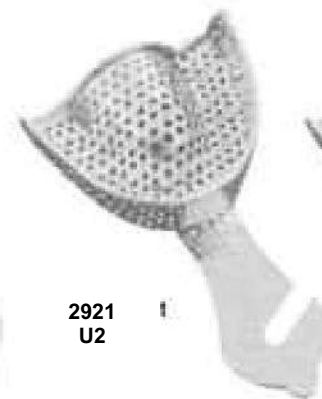

2921
U2

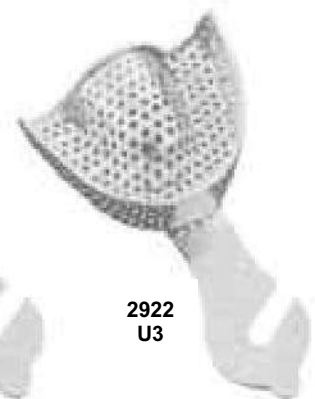

2922
U3

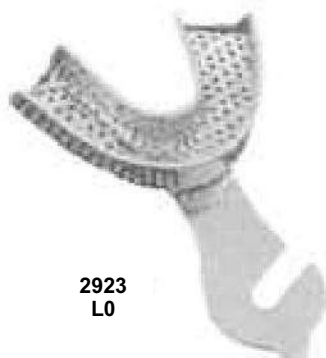

2923
L0

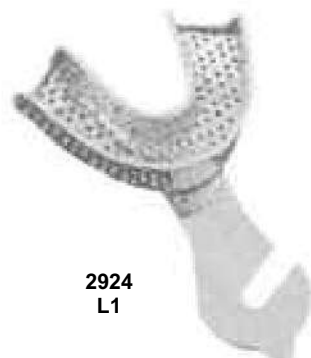

2924
L1

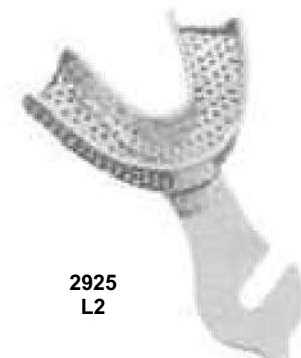

2925
L2

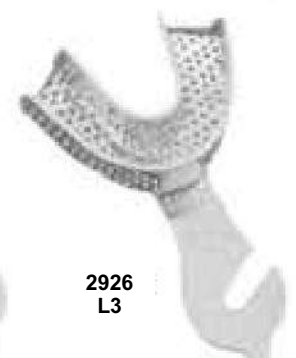

2926
L3

Made of 18/8 Stainless Steel, Perforated Full Denture Set of 8



Impression Trays

Impression Trays For Crown & Bridge Work



2927
U1P



2928
L1P

SOLID



2929
U1P



2930
L1P

PERFORATED

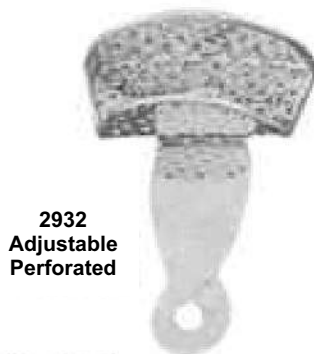

2932
Adjustable
Perforated



2933
Adjustable
Solid

PERFORATED



2931-A
For upper right jaw
For lower left jaw

2931-B
For upper left jaw
For lower right jaw

Available in 4 sizes
1.....44 mm
2.....55 mm
3.....60 mm
4.....65 mm

SOLID



2931-C
For upper right jaw
For lower left jaw

2931-D
For upper left jaw
For lower right jaw

Available in 4 sizes
1.....44 mm
2.....55 mm
3.....60 mm
4.....65 mm



Articulators



2934



2935



2936



2937



2939



2938



Articulators



2940



2941



2942



2943



2944



2945



2946



2947



Hollowares



2948
Instrument Tray of 20 Pcs

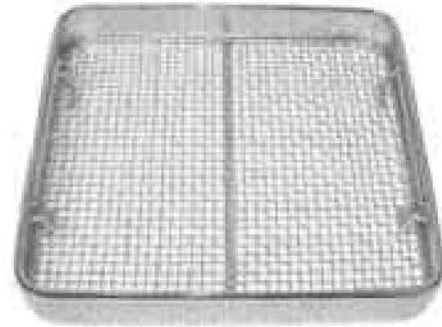

2951
Instruments Riddle



2949
Instrument Tray of 7 Pcs



2949-A
Instrument Tray of 10 Pcs



2950
Instrument Tray of 5 Pcs

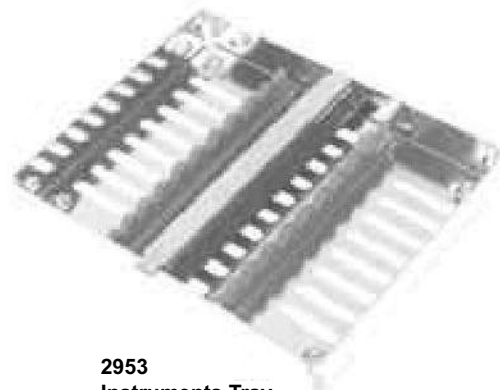

2953
Instruments Tray

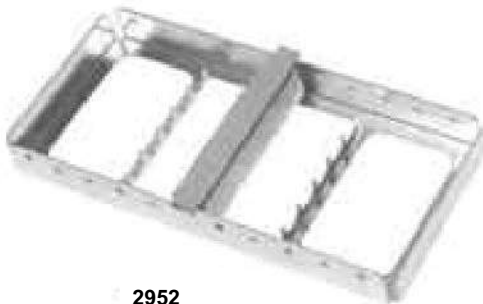

2952
Instrument Tray of 5 Pcs



2954
Instruments
Tray Perforated



2955
Instruments
Tray Perforated
Base



2956
Instruments
Tray Solid Base



Hollowares



2957
Pulpectomy Tray



2958
Sterilizing Box
Available Sizes
17x17x3 cm
20x10x6 cm
30x14x8 cm



2959
Endo Tray Box



2960
Finger Cup



2961
Bur Box

2962
Sterilizing Drum
150x150mm
175x175mm
190x190mm
200x140mm
200x200mm
240x225mm
225x225mm
240x240mm
290x160mm



2963
Sterilizing Drum
280x240mm
230x150mm
300x250mm
340x160mm
250x250mm
390x200mm
280x300mm
100x100mm
150x120mm



Sterilizing Boxes & Instrument Trays



2964
Instruments Box



2965
Instruments Box



2966
Instruments Box



2967
Instruments
Sterilizer 150x75 mm



2968
Endodontic Box



2969
Sterilizing Box
320x120mm



2970
Instruments Tray



2971
Instruments Tray



2972
Instruments
Tray (Perforated)



2973
Instruments
Tray
Shallow(Mayo)



2974
Scaler Tray
20x10x1.5
cm



2975
Scaler Tray



2976
Scaler Tray



Hollowares



2977

2978

2979

2980

Forcep and Thermometer Jars

2981

Cotton Holding Jar
60x50 mm



2982
Spitten Mug

2983
Spirt Burner With
Wick Stainless Steel
18/10 Capacity 150ml,
80ml

2984
Spirt Burners With
Wick Stainless Steel
18/10 Capacity 70ml



2985
Dressing Jar

2986
Dressing Jar

2987
Irrigator(Douch Can)

2988
Mesuring Jug



Hollowares



2989
Sponge Bowl



2990
Wash Basin 300mm-
350mm-400mm



2994
Kick Bucket With Trolley



2991
Sponge Bowl



2992
Gallipot



2993
Medicine Cup



2995
Kidney Tray Shallow 150mm-
200mm-250mm-300mm



2997
Kidney Tray Without Lid
150mm-200mm-250mm-
300mm



2997
Kidney Tray With Lid 150mm-
200mm-250mm-300mm



2998
Tube Rack Stainless Steel 18/10



2999
Needle Case Rectangle
Needle Case Round With Cover
90x15



3000
Dustbin Without Stand
6-10-12 Ltr

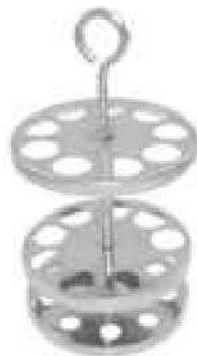

3001
Tube Rack Round Model
Stainless Steel 18/10



3002
Dustbin Without Stand & Cup
6-10-12 Ltr

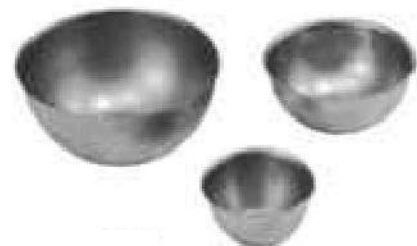

3003
Lotion Bowl With Lip 40-60-80-
100-120-150-180-200mm



Scissors with Tungsten Carbide Inserts



3004
Standard

14.5c
m
16.5c
m
18.5c
m

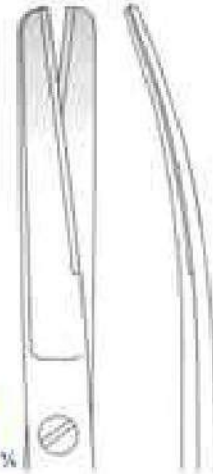

3005
Standard

14.5c
m
16.5c
m
18.5c
m



3006
Standard

14.5c
m
16.5c
m
18.5c
m



3007
Standard

14.5c
m
16.5c
m
18.5c
m



3008
Standard

14.5c
m
16.5c
m
18.5c
m



3009
Standard

14.5c
m
16.5c
m
18.5c
m



Scissors with Tungsten Carbide Inserts

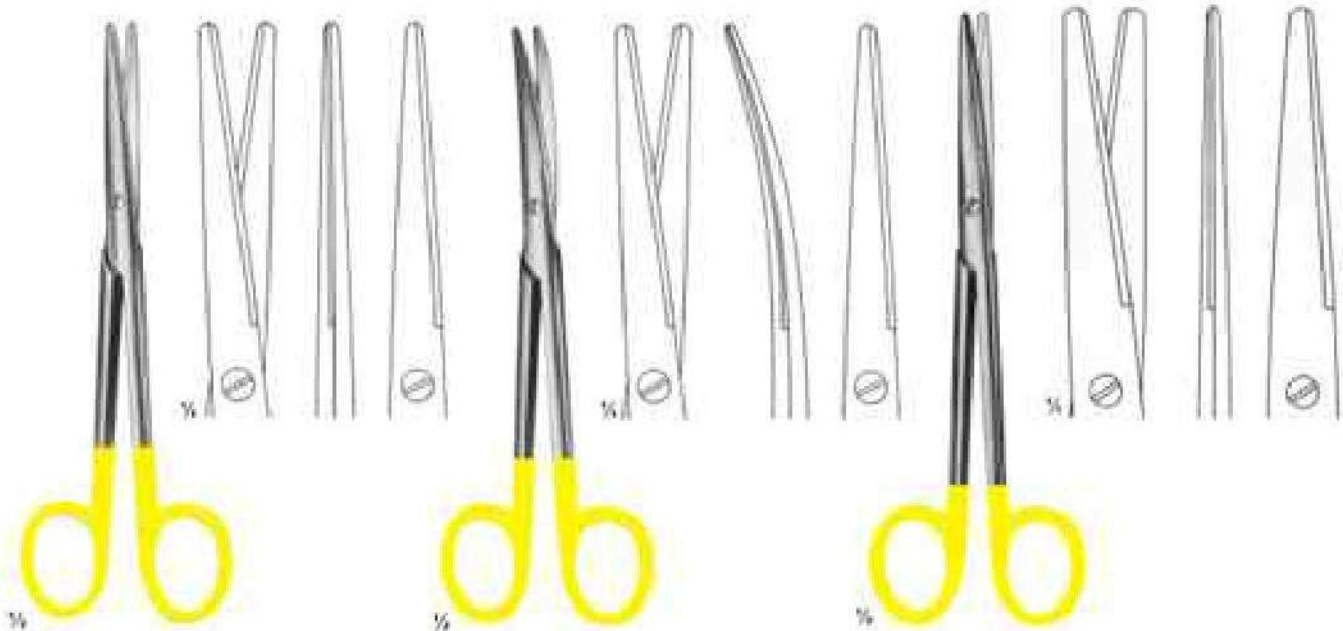

3010 MAYO-LEXER
Straight
16cm

3011 MAYO-LEXER
Curved 16cm

3012 LEXER
Straight
16, 21
cm

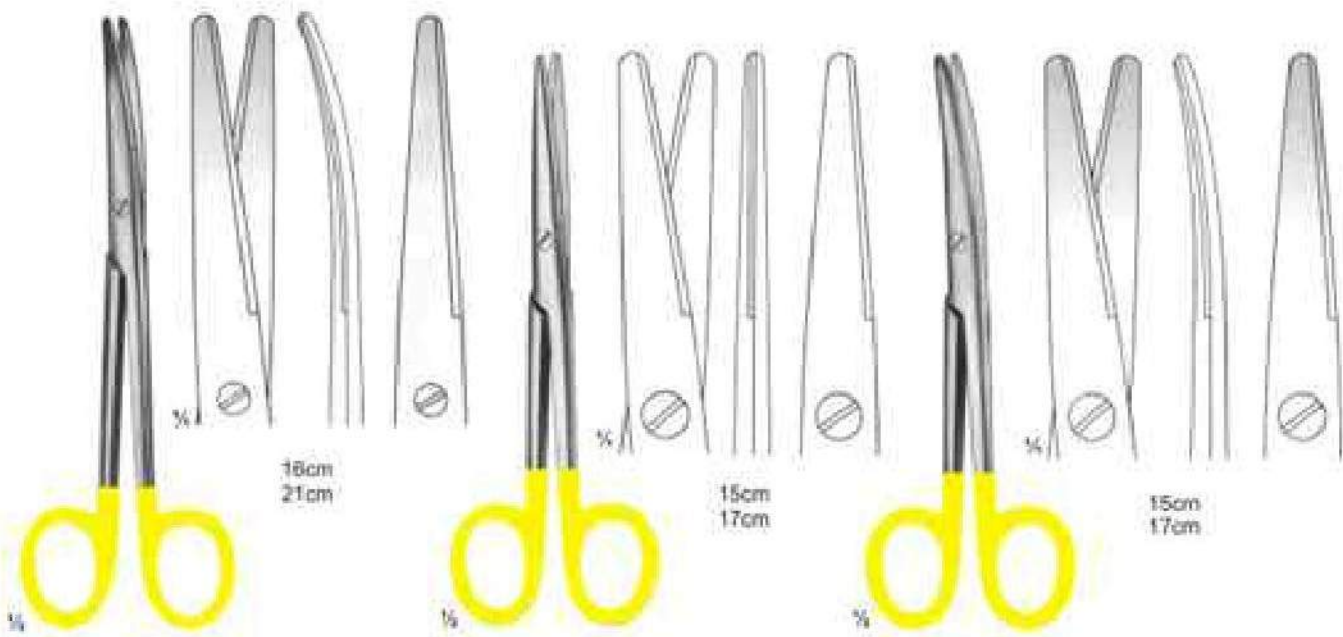

3012 LEXER
Curved
16, 21
cm

3014 MAYO-STILLE
Straight
15, 17 cm

3015 MAYO-STILLE
Curved
15, 17 cm



Scissors with Tungsten Carbide Inserts



3016
METZENBAUM
Straight



3017
METZENBAUM
Curved



3018
METZENBAUM
Curved



3019
METZENBAUM FINO
Straight



3020
METZENBAUM FINO
Curved



3021
METZENBAUM FINO
Sharp

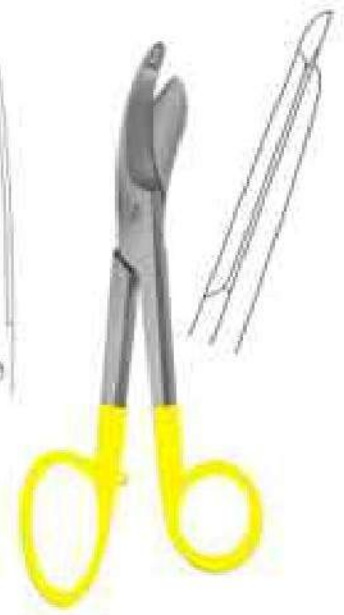

3022
BRUNS
235
mm



Scissors with Tungsten Carbide Inserts

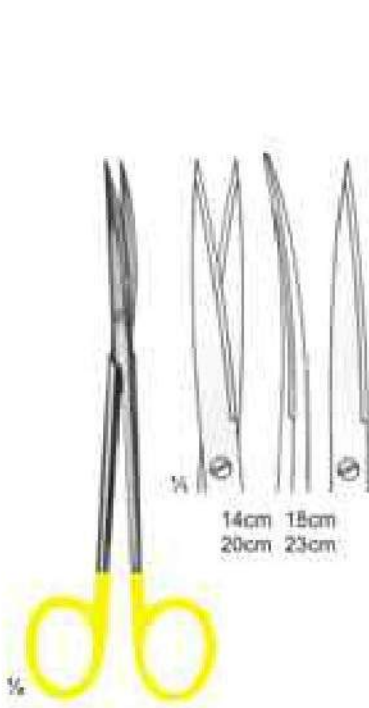

3023
METZENBAUM FINO



3024
METZENBAUM FINO

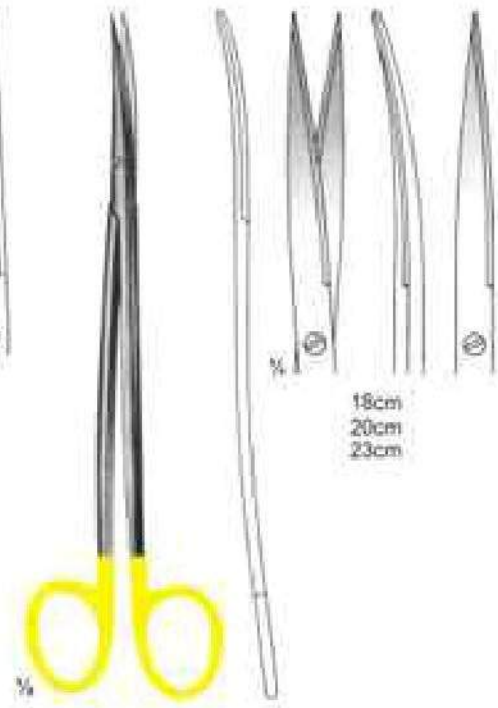

3025
METZENBAUM FINO



3026
METZENBAUM FINO

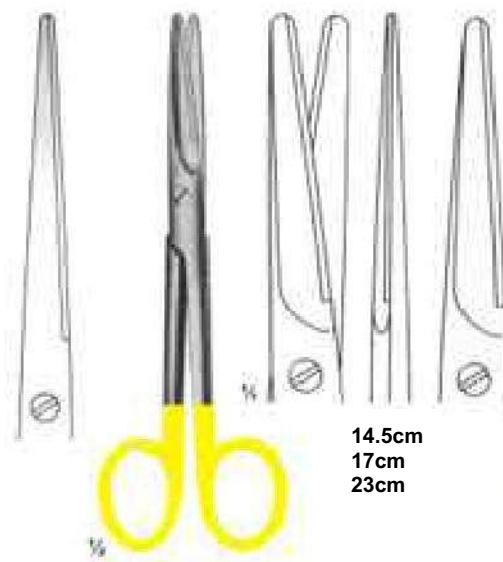

3027
MAYO
Straight

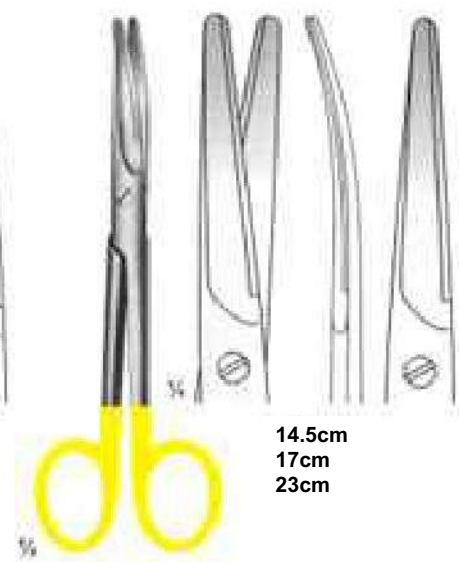

3028
MAYO
Curve
d



Scissors with Tungsten Carbide Inserts



**3029
SIMS**

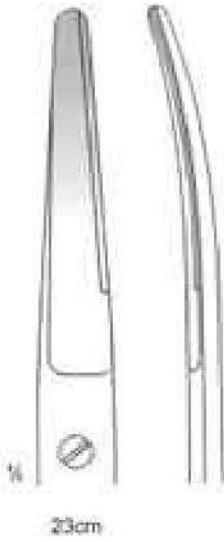

23cm

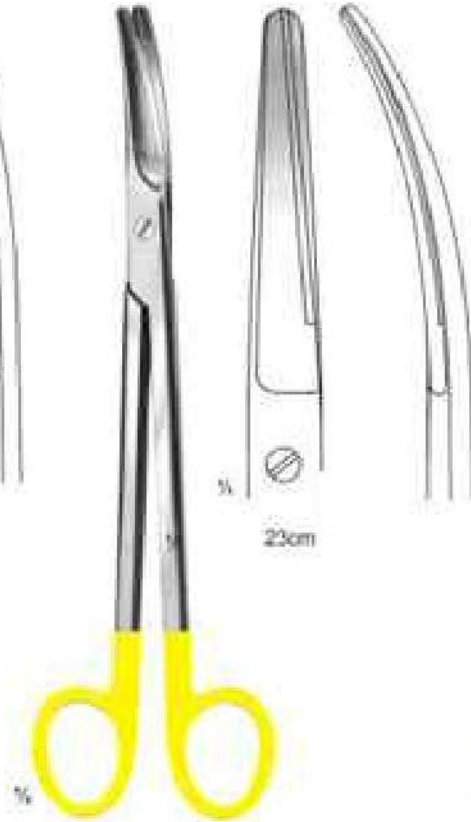

**3030
PARAMETRIUM**



23cm

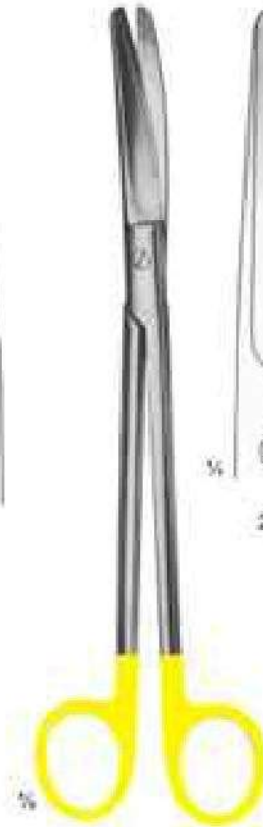

**3031
MAYO-HARRINGTON**

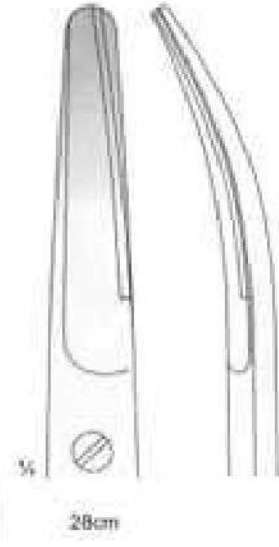

28cm



**3032 KELLY
Straight
16cm**



**3033 KELLY
Curved
16cm**



**3033
DEA
N
17cm**



**3035
LAGRANGE
Double-Curved
11.5cm**



Scissors with Tungsten Carbide Inserts



**3036
DE-BAKEY**



**3037
DE-BAKEY**



**3038
GOLDMAN FOX
13cm**



**3039
GOLDMAN FOX
Double Curved
13cm**



**3040
GOLDMAN FOX
13cm**



**3041
Fine Scissors
Straight
11, 5cm**

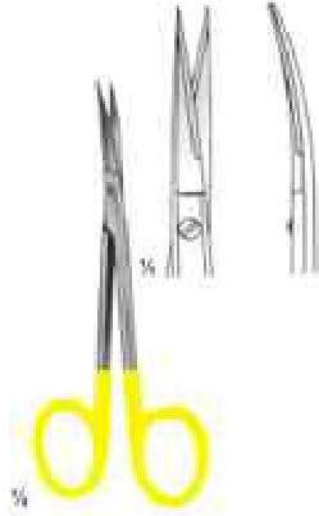

**3042
Fine Scissors
Curved
11, 5cm**



**3043
Fine Scissors
Angled
11, 5cm**



**3044
FAGNELL
Curved
12cm**



**Scissors & Dissecting Forceps
With Tungsten Carbide Inserts**

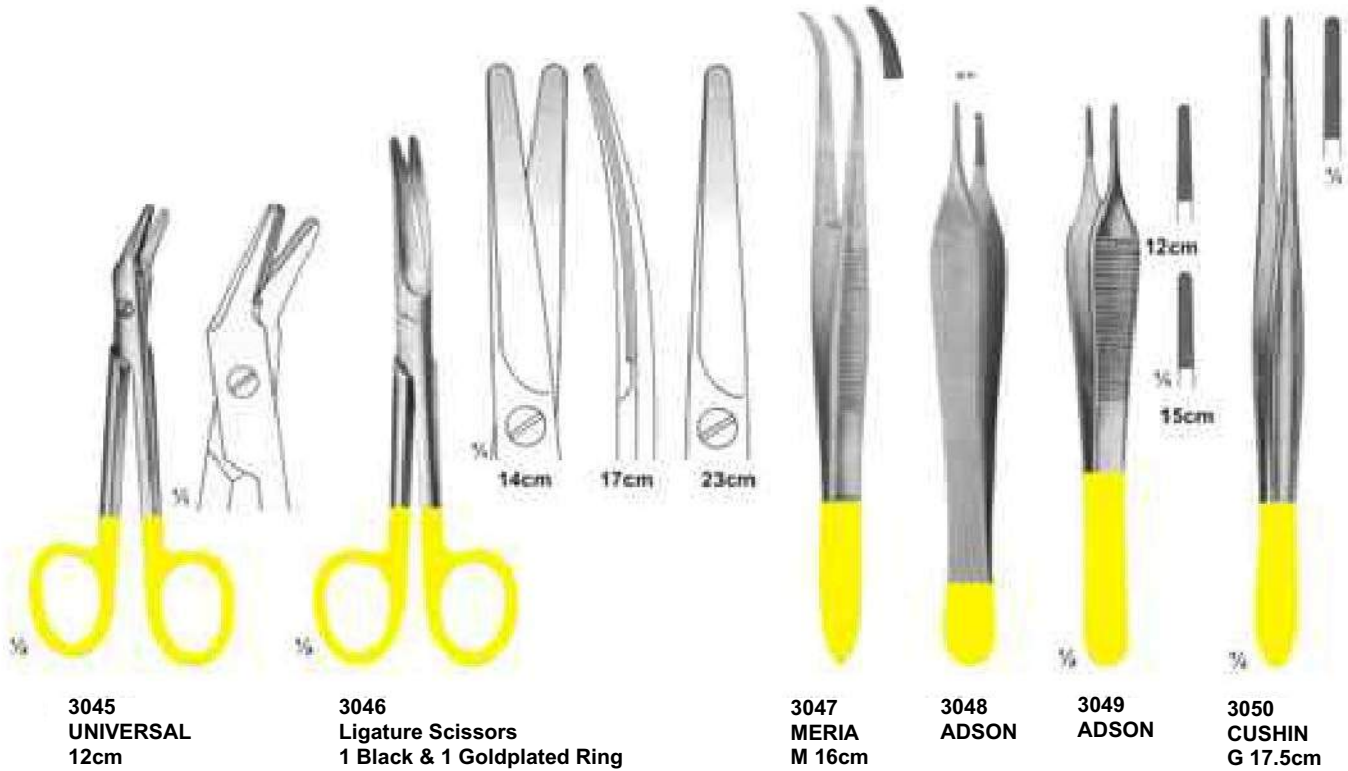

**3045
UNIVERSAL
12cm**

**3046
Ligature Scissors
1 Black & 1 Goldplated Ring**

**3047
MERIA
M 16cm**

**3048
ADSON**

**3049
ADSON**

**3050
CUSHIN
G 17.5cm**

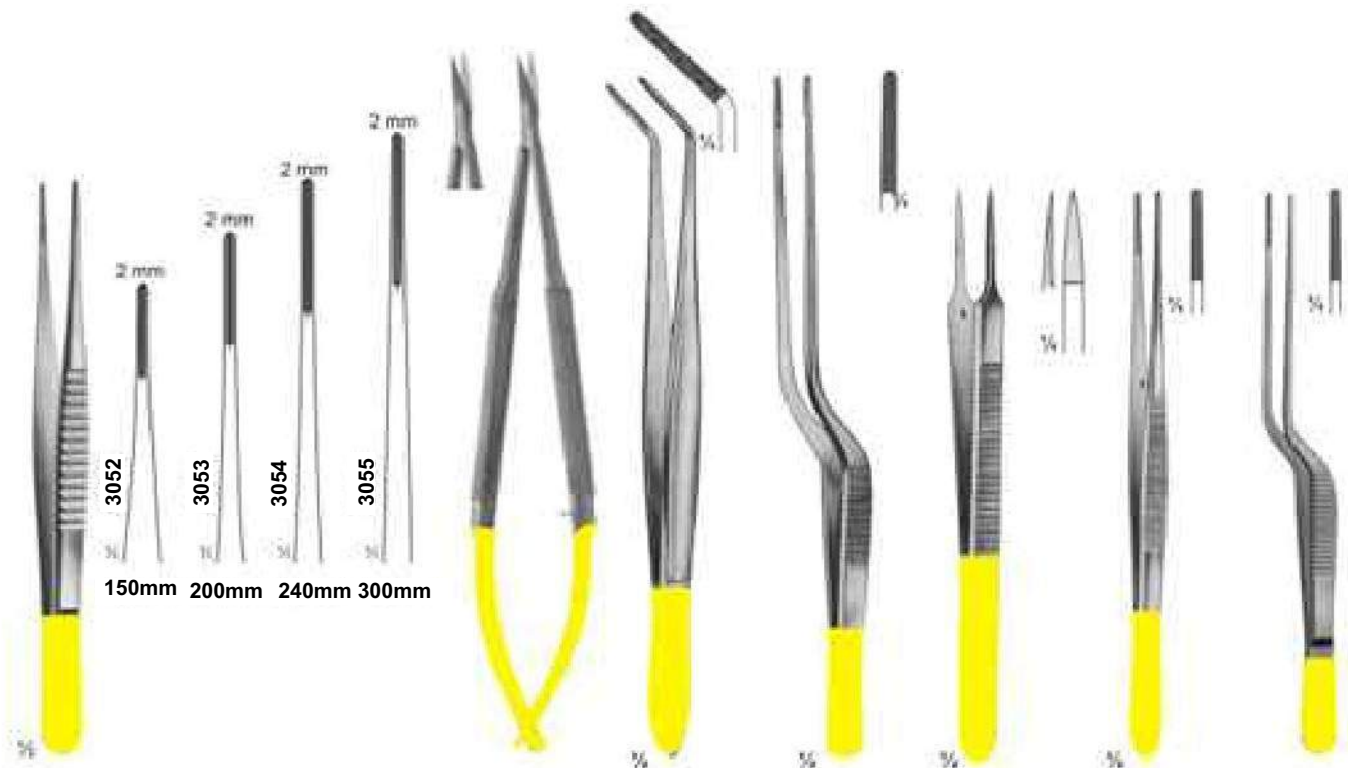

**3051
DEBAKEY
17.5cm**

**3056
CASTROVIEJO
Curved
15cm**

**3057
CUSHING
18cm**

**3058
CUSHING
TAYLOR
18cm**

**3059
Dressin
g
Forceps
15cm**

**3060
SEMKE
N 15cm**

3061



Dissecting Forceps & Needle Holders
T.C Instruments



3062 WANGENSTEIN

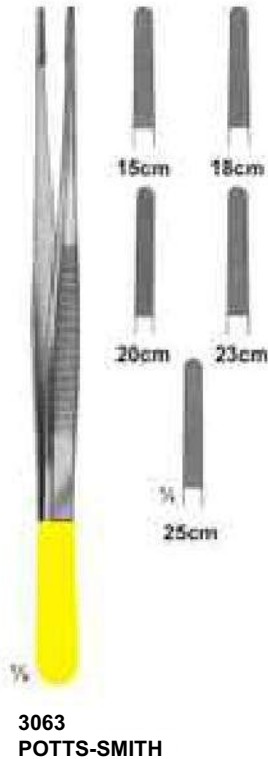

3063 POTTS-SMITH



3064 OEHLER

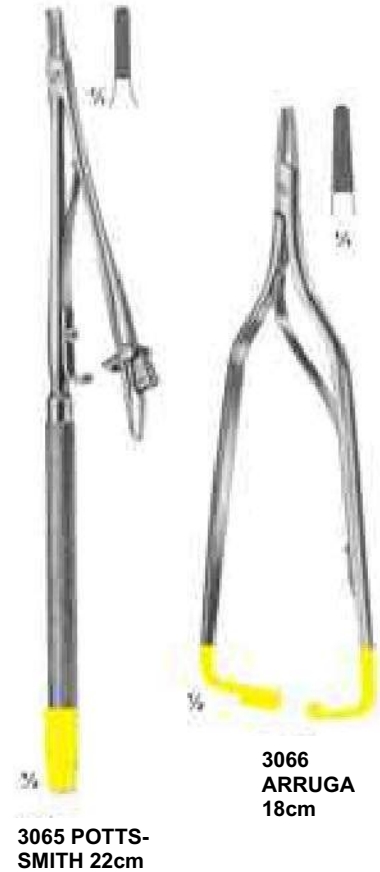

3065 POTTS-SMITH 22cm

3066 ARRUGA 18cm



3067 Hepp SCHEIDL E 18cm



3068 KALT with catch 135mm



3069 CASTRIVIEJO Straight 14cm



3070 CASTRIVIEJO Curved 14cm

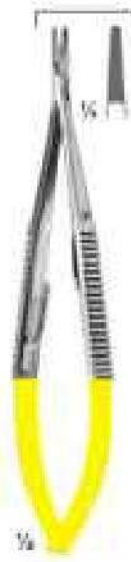

3071 CASTRIVIEJO Straight 14cm



3072 CASTRIVIEJO Curved 14cm

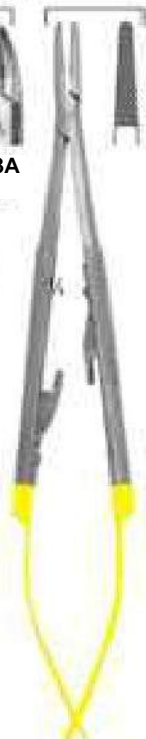

3073 CASTRIVIEJO Straight

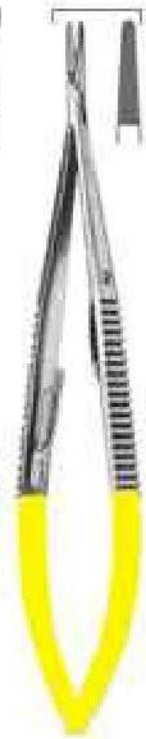

3074 CASTRIVIEJO Straight



3073A Cvd

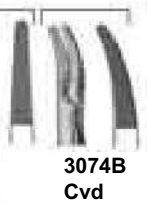

3074B Cvd



Needle Holders With T.C Inserts

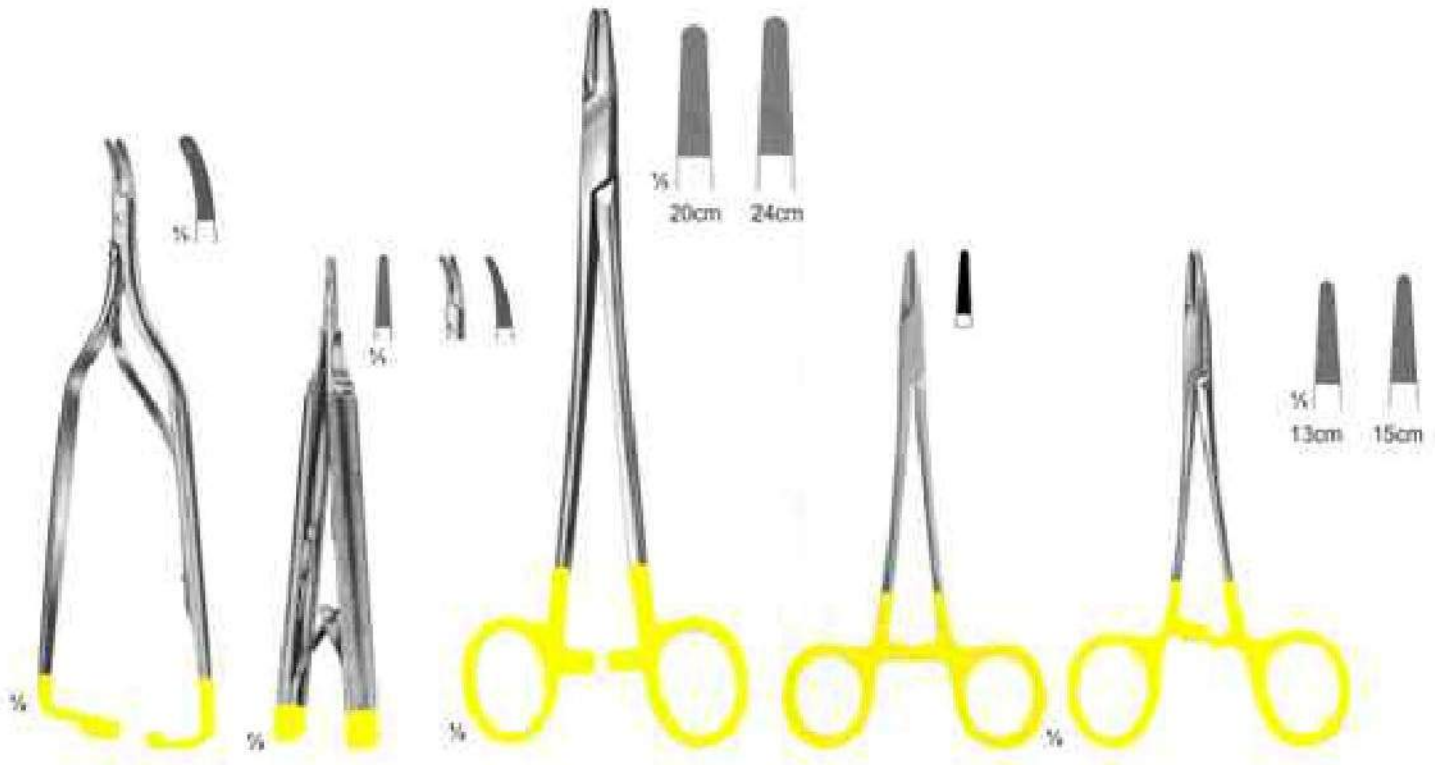

3075
ARRUGA
Curved
16cm

3076
CARTROVIEJO
13cm

3077
HEGAR
20, 24cm

3078
SMOOTH TIP
15cm

3079
HALSEY
13, 15cm

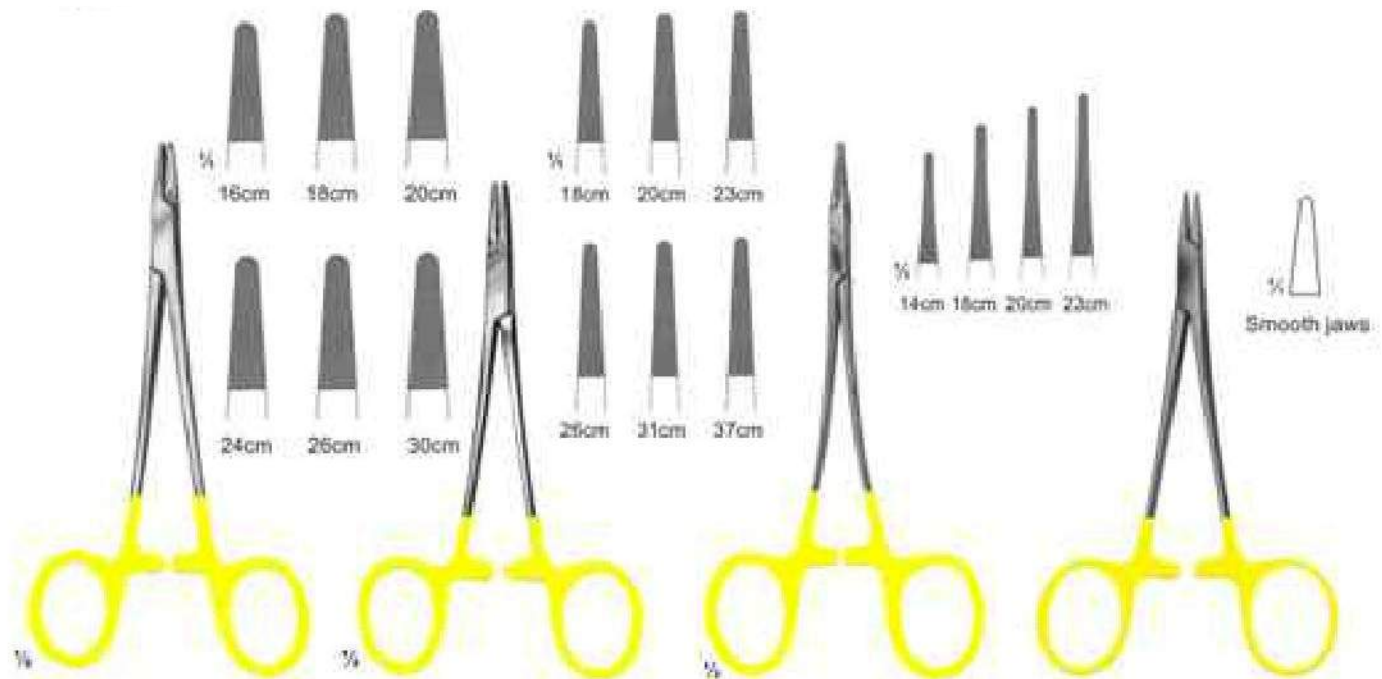

3080
MAYO-HEGAR

3081
DE BAKEY

3082
HEGAR VASCULAR

3083
WEBSTER
125mm



**Needle Holders With
Tungsten Carbide Inserts**

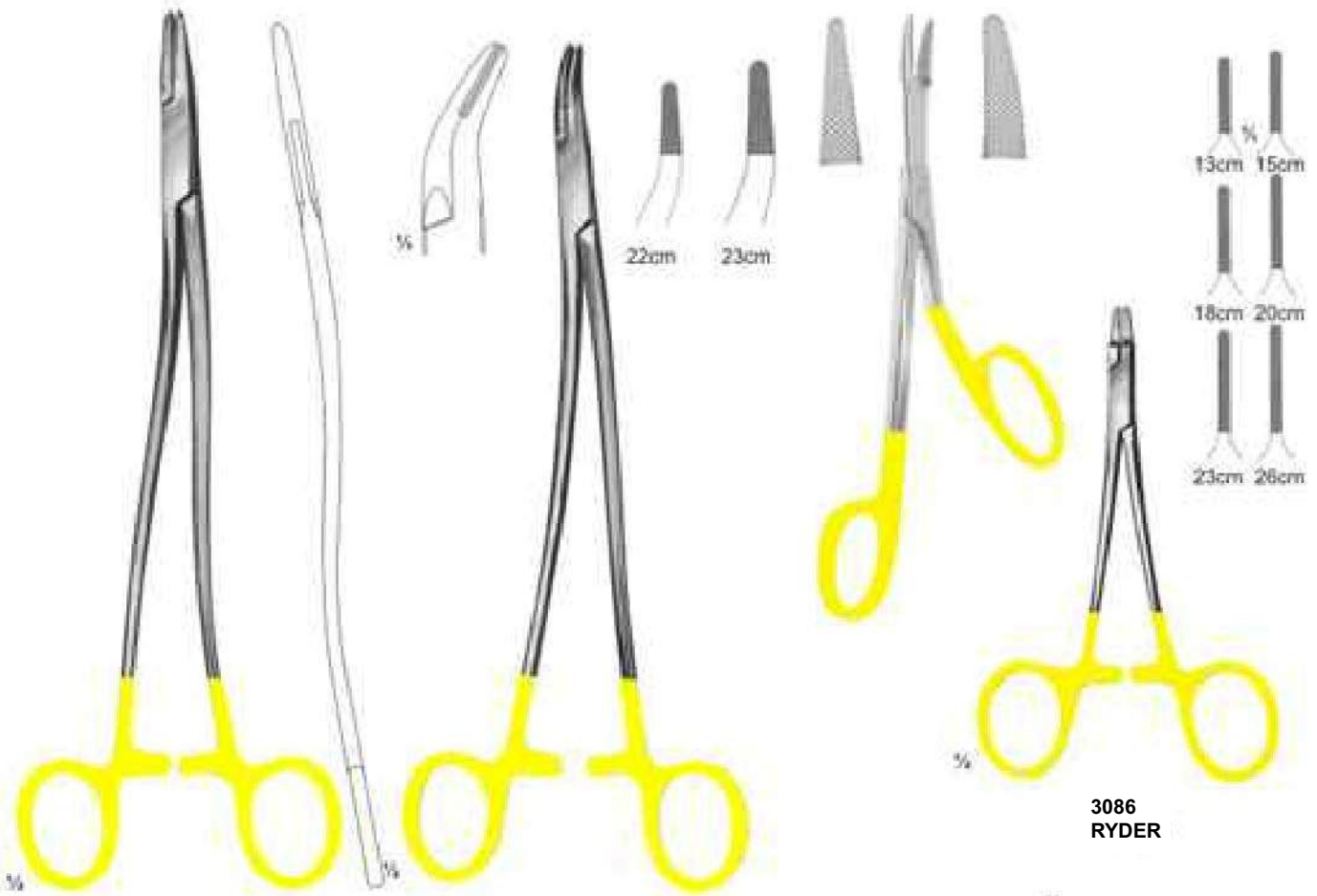

3084
BOZEMANN WERTHEIM
20, 24, 26 cm

3085
BTRATTE

3086
RYDER

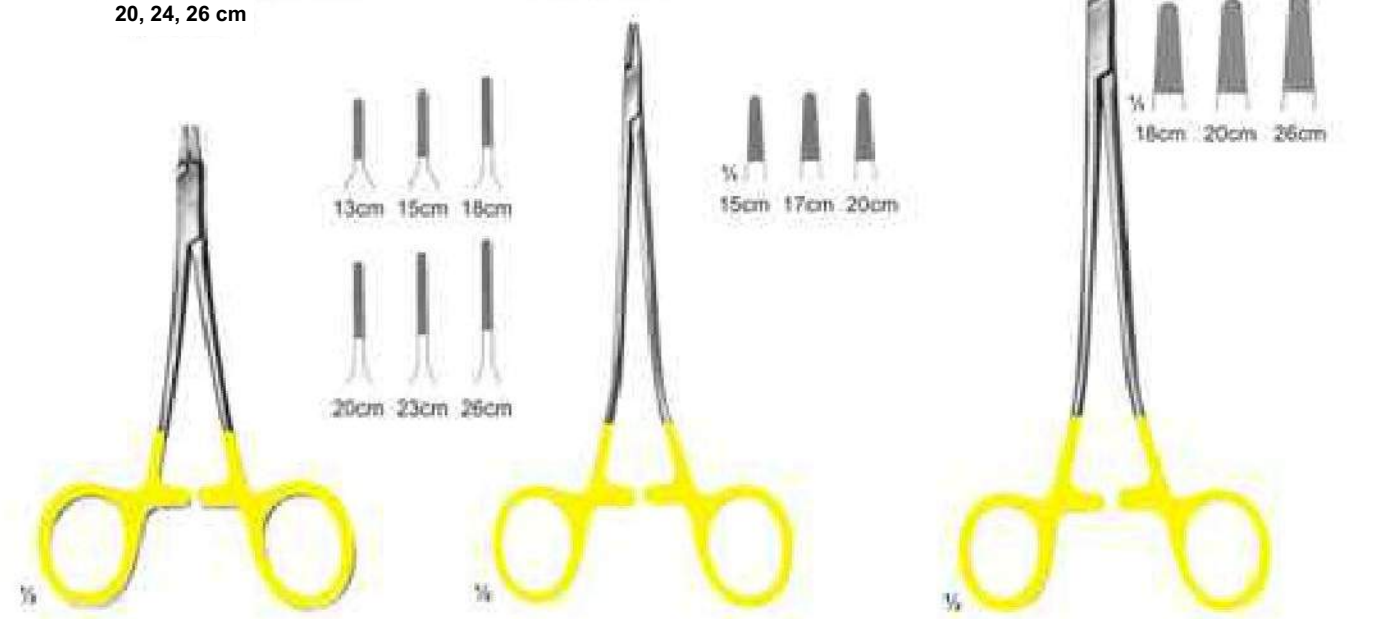

3087
RYDER-VASCULAR

3088
MARTIN

3089
SAROT

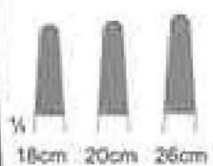
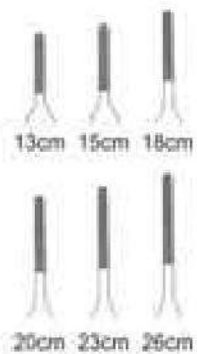



**Needle Holders With
Tungsten Carbide Inserts**

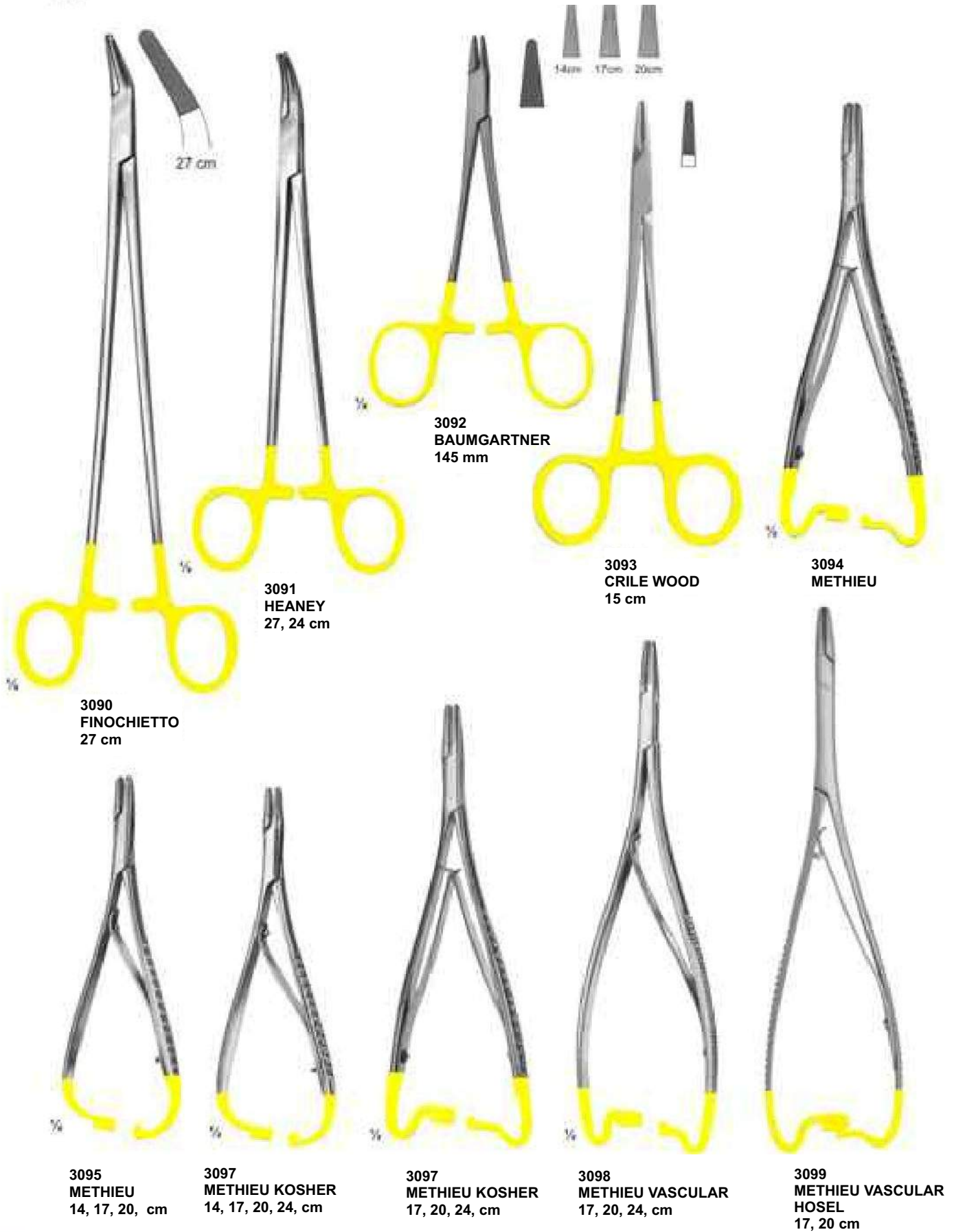

**3090
FINOCHIETTO
27 cm**

**3091
HEANEY
27, 24 cm**

**3092
BAUMGARTNER
145 mm**

**3093
CRILE WOOD
15 cm**

**3094
METHIEU**

**3095
METHIEU
14, 17, 20, cm**

**3097
METHIEU KOSHER
14, 17, 20, 24, cm**

**3097
METHIEU KOSHER
17, 20, 24, cm**

**3098
METHIEU VASCULAR
17, 20, 24, cm**

**3099
METHIEU VASCULAR
HOSEL
17, 20 cm**

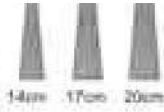



**Needle Holders With
Tungsten Carbide Inserts**



3100
METHIEU RYDER
17,20,24 cm

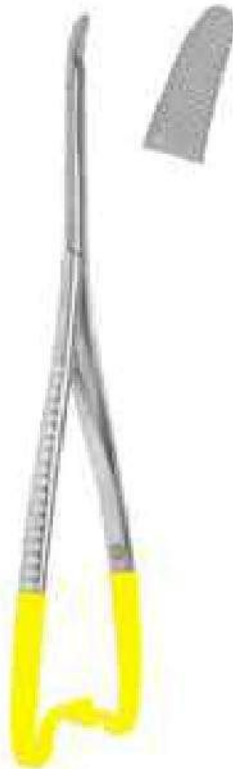

3101
Hosel
Curved
20 cm



3102
LANGENBECK
20 cm



3103
LANGENBECK
20,25 cm



3104
LANGENBECK
20,25 cm



3105
LUEHTY BECK
20, 25 cm



3106
LUEHTY BECK
20, 25 cm



3107
LANGENBECK
18,20,23 cm

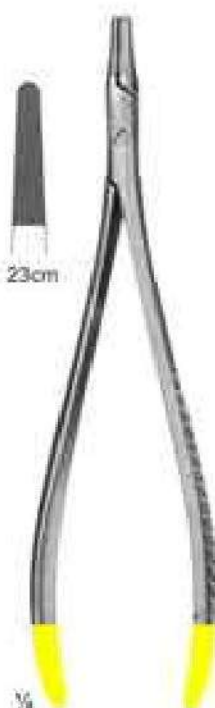

3108
LANGENBECK
18,20,23 cm



**Wire Cutter Pliers With
Tungsten Carbide Inserts**



3109 TOENNIS
Elastic pattern for
dura or intestinal suture
180 mm



3110
Cutting Plier
12 cm

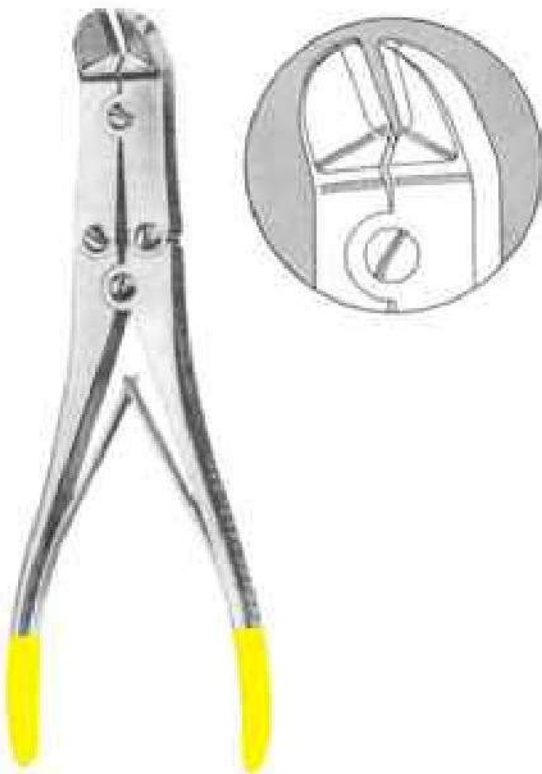

3111
MULLAR CLAUS
22 cm

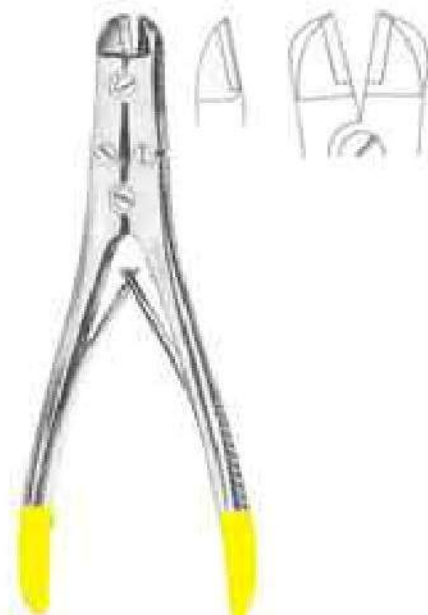

3112
PLIER
17.5 cm



Alphabetical Index

A

Adams, Pliers	174
Aderer, Pliers	174
Adson, Forceps	158,207
Adson, Tweezers	151
Ainsworth, Rubber Dam Punch	147
Albee	143
Albrecht, Tweezers	155
Allen, Tweezers	155
Allis, Tissue Forceps	158
Amalgam Applicators	97
Amalgam Condensers	97
Amalgam Pluggers	97
Amalgam Carriers	145
Amalgam Guns	145
Andresen, Pliers	175
Andrews, Tongue Depressor	160
Angle, Pliers	169,174
Apical, Elevator	57,63
Arruga, T.C. Needle Holder	208,209
Articulators	194-195
Aspirating Syringes	149
Allen 9A, Elevator	50

B

Baby-Allis, Tissue Forceps	158
Band Removing Pliers	170
Bane, Rongeurs	179
Barnhart, Curettes	110,116
Barry, Elevator	66,69
Baum Gartner, Needle Holder	180,211
Bee Be, Scissors	186
Bein, Elevator	54,61
Beyer, Rongeurs	179
Bird Beak Pliers	167
Blumenthan, Rongeurs	176
Boley Gauge	143
Bone Curettes	129
Boynon, Needle Holder	181
Bozemann-Wertheim, T.C. Needle Holder	210
Bracket, Pliers	170
Brewer, Rubber Dam Instruments	147
Brown, Tissue Forceps	158
Brown-Adson, Tissue Forceps	158
Bruns, T.C. Scissors	203
Buchs, Retractor	162
Burnishers	99-100
Ball Chain	146
Boley Gauge,	143

Bone Gauge,	144
Bone Mill Forcep,	139
Bone Pluggers,	140
Bracket, Gauge	144
Buser, Elevator	52

C

Carvers	102,103
Castroviejo, Needle Holder	181,208,209
Castroviejo, scissors	186
Castroviejo, Gauge	144
Castroviejo, Sclerer Marker	144
Cement Instruments	118,119,121
Cement Spatulas	120,122
Chisels	103
Chompret, Elevator	63
Cleveland, Rongeurs	177,178
College, Tweezers	152,154
Collier, Needle Holder	180
Collin, Retractor	162
Columbia, Curettes	110,111,116
Composite Placement	104,105
Con Scodellino, Wax Knives	126
Cord Packers	95
Cottle, Scissors	184
Coupland, Elevator	58
Crane-Kaplan	128
Crile, Forceps	157
Crile, Needle Holder	181
Crile-Wood, Needle Holder	180
Crown Instruments	135,136
Crown Removers	134,135
Crown Shell, Pliers	166
Cryer, Elevator	55,58,69
Cushing, T.C. Forceps	207
Cushing, Tweezers	151
Cushing-Taylor, T.C. Forceps	207

D

De Bakey, T.C. Forceps	207
De Bakey, Scissors	184,186,206
De Bakey, T.C. Needle Holder	209
De La Rosa, Pliers	169
Deaver, Scissors	184
Denhart, Mouth Gag	160
Derf, Needle Holder	180
Disposable Products	117
Dr.Sader, Elevator	69
Dressing Forceps	207
Dean Scissors	186,205



Alphabetical Index

E

Elevators	51
Endodontic Condensers	86,87
Emert, Wax Knives	126
Excavators	89-91
Explorers	80-82,91-94
Extracting forceps (American Pattern)	36-49
Extracting forceps (English Pattern)	1-24
Extracting forceps (fitting handle)	25-33
Extracting forceps (For Children)	34

F

Fahnenstock, Wax Knives	126
Files	125
Filling Instruments	108,107
Fine, T.C. Scissors	206
Finochietto, T.C. Needle Holder	211
Finochietto, T.C. Needle Holder	211
Fischer, Pliers	175
Flagg, Tweezers	154
Flohr, Elevator	56
Fomon, Tissue Retractor	164
Freer, Elevator	52
Friedman, Rongeurs	178
Furrer, Pliers	174
Film Hanger	146
Finger Cup	197
Flohr, Elevator	57
Freer	15,16,
Elevator	52

G

Gardner, Bone Chisels	132
Gardner, Needle Holder	180
Gardner, Rongeurs	178
Gillies, Hook	164
Gillies, Tweezers	151
Goldman Fox, T.C. Scissors	206
Goldman Fox, Curettes	112,113
Goldman Fox 14, Elevator	50
Goldman Fox, knives	114
Goslee, Pliers	175
Gracey Curettes	108,109,116

H

Halsey, T.C. Needle Holder	209
Handles	72
Hartman, Rongeurs	179

Hatchets	95
Heaney, T.C. Needle Holder	211
Hegar, T.C. Needle Holder	209
Hegar-Vascular, T.C. Needle Holder	209
Heidbrink, Elevator	64,67,69
Heidbrink, Elevator	57
Howard 9H, Elevator	52
Height Gauge,	143
Hepp-Scheidle, T.C. Needle Holder	208
Hlsted-Mosquito, Forceps	159
Hoes	95,125
Hollow Wares	196-200
How, Pliers	167,174
Howard, Bone Files	131
Hylin, Elevator	61

I

Implants Instruments	
Impression Trays	137-141
Iris Scissors	187-193
Ivory, Rubber Dam Instruments	183
	147

J

Jarabak, Pliers	165
Joseph, Scissors	183
Johnson, Pliers	169,175
Joseph, Tissue Retractor	164

K

Kait, T.C. Needle Holder	208
Kelly, Forceps	159
Kelly, Scissors	183
Kelly Scissors	205
Kim's Plier	165
Kirkland, knife	114
Knives	125
Knowles, Scissors	184
Kocher, Retractor	162
Kocher-Langenbeck, Retractor	162
Kopp, Elevator	60,68
Kopp, Tweezers	151

L

Lab & Office Pliers	166
Landgraf, Tweezers	154
Langenbeck, Pliers	175
Langenbeck, Retractor	162



Alphabetical Index

Langenbeck, T.C. Needle Holder	212
Langer, Curettes	110,116
Langhals, T.C. Needle Holder	212
Lecluse, Elevator	65
Lessmann, Wax Knives	126
Lexer, T.C. Scissors	202
Lichtenberg, T.C. Needle Holder	212
Ligature , T.C. Scissors	207
Lip & Cheek Retractors	161,162
Lister, Scissors	184
Littauer, Scissors	186
Littler, Scissors	184
Locklin, Scissors	186
London Hospital, Elevator	62
London-College, Tweezers	154,155
Lucae, T.C. Forceps	
Luehty-Beck, T.C. Needle Holder	212
Lwanson, Crown Gauge	143
Lagrange, Scissors	186,205
Littaure, Scissors	186
Lwanson, Crown Gauge	143

M

Martin, T.C. Needle Holder	210
Mathieu, Needle Holder	181,211
Mathieu-Kosher, T.C. Needle Holder	211
Mathieu-Ryder, T.C. Needle Holder	212
Mathieu-Vascular, T.C. Needle Holder	211
Mayo Harrington, T.C. Scissors	205
Mayo, Scissors	185,204
Mayo-Hegar, Needle Holder	181
Mayo-Hegar, T.C. Needle Holder	209
Mayo-Lexer, T.C. Scissors	202
Mayo-Stille, T.C. Scissors	202
Mayo-Stille Scissors	185
Mc Kellops, Pliers	175
Mccalls, Curettes	110,111,116
Mcindoe, Tweezers	151
Mead, Bone Mallets	133
Mead, Elevator	64
Mead, Rongeurs	179
Meriam , T.C. Forceps	207
Meriam, Tweezers	153,155
Metzenbaum Fino, T.C. Scissors	203,204
Metzenbaum, Scissors	185,203
Micro Surgery Set	182
Micro-Adson, Tweezers	151
Micro-Friedman, Rongeurs	178
Middledorpf Retractor	162
Miller, Articulating Forceps	147
Miller, Bone Files	130

Mini-Blumenthan, Rongeurs	176
Molt, Elevator	50
Molt, Mouth Gag	160
Molt 9, Elevator	50
Morrison, Elevator	56
Mouth Mirrors with Handles	73
MSY, Pliers	175
Mullar Claus, Wire Cutting Pliers T.C.	213

N

Nance, Pliers	168,169,174
Napkin Holders	146
Neivert, Needle Holder	180
Nelson-Metzenbaum, Scissors	185
Non Chill	146

O

O'Brien, Pliers	168
Obturation Instruments	88
Ochsenbein	128
Ordan, knife	114
Oehler, T.C. Forceps	208
Olsen-Hegar, Needle Holder	180
Optical Pliers	168
Orthodontic Cutters, T.C.	172
Orthodontic Distal & Cutters	173
Orthodontic Pliers, T.C.	171
Ott, Elevator	62

P

Parametrium, T.C. Scissors	205
Partsch, Bone Chisels	133
Partsch, Bone Mallet	133
Pean, Forceps	157
Peeso, Pliers	166,175
Peets, Forceps	157
Perry, Tweezers	151
P.K. Thomas,	96
Pich,	98
Pluggers,	98
Prichard, Elevator	50
Plastic Handle Elevators	70
Polokoff, Bone File	131
Pott, Elevator	51
Potts-Smith, T.C. Forceps	208
Potts-Smith, T.C. Needle Holder	208
Probes	82-85,91,94

Q

Quinby, Scissors	183
------------------	-----



Alphabetical Index

R

Ragnell, T.C. Scissors	206
Retainers, Bands	146
Reynolds, Pliers	169,174
Root Planning Curettes	115
Root splinter forceps	35
Roux, Retractor	162
Rubber Dam Clamps	148
Rubber Dam Holder	147
Rule, Curette	110
Russian, Tissue Forceps	158
Ryder, T.C. Needle Holder	210
Ryder-Vascular, T.C. Needle Holder	210

S

Sarot, T.C. Needle Holder	210
Scalers	75-79
Scalpel Handles	71
Schwarz, Pliers	168,175
Schluger, File	114
Seldin, Elevator	50,55,67
Select, Tweezers	151
Semken, T.C. Forceps	207
Semkin, Tissue Forceps	158
Senn, Tissue Retractor	164
Separating Pliers	166
Sims, T.C. Scissors	205
Spatulas	123
Spencer, Scissors	186
Spencer-Wells, Forceps	157
Spreaders	87
Split Chisels,	128
Spring Bow Divider	143
Standard, T.C. Scissors	201
Standard, Tweezers	151
Steiner, Pliers	166
Sterilizing & Lab Instruments	156
Sterilizing Forceps,	163
Stevens, Needle Holder	181
Stevens, Scissors	183
Stille, Scissors	185
Stratte, T.C. Needle Holder	210
Strip Holder Clips	146
Syringes	150
Suction Tubes,	140,142
Sugarman, File	114

T

Toennis, Wire Cutting Pliers T.C.	213
-----------------------------------	-----

Toennis-Adson, Scissors	184
Toennis, Tissue Retractor	164
Towel Clamps, Napkin Holders	159
Tweed, Pliers	168
Telescope, Crown Plier	136
Traymann, Crown Remover	128

U

Universal, T.C. Scissors	207
Universal, Pliers	174
Universal, Elevator	135
Utility Plier	165

V

Vernier, Measuring Instruments	143
Vernier Gauge	143

W

Wakefield, Bone Chisels	132
Waldron, Pliers	174
Waldsachs, Pliers	174
Wangensteen, T.C. Forceps	208
Warwick-James, Elevator	62
Waugh, Tweezers	151
Wax & Modeling Carvers	120
Wax & Plaster Knives	127
Wax Carvers	101
Wax, Porcelain Instruments	118,119,121
Webster, Needle Holder	160,209
Weingart, Utility Pliers	167
Weitlaner, Retractor	160
West, Elevator	50
White, Rubber Dam Instrument	147
Wieder, Tongue Depressor	160
Winter, Elevator	65,69
Wire & Clasp Bending Pliers	170
Wire Bending Pliers	166
West, Elevator	50
Wire Cutter	165
Woodson,	98

Y

Young, Pliers	168,174
---------------	---------

Z

Zuncher, Measuring Instrument	143
Zuricher, Gauge	143





ZIANA INDUSTRIES

 sales@zianaindustries.com
expziana@gmail.com
info@zianaindustries.com

 www.zianaindustries.com

 +92-52-4261495 , +92-52-4265791

 +92-321-9408040

 +92-52-4264970

**Islam Nagar Road Pacca Garah
Sialkot 51310 - Pakistan.**